

SIEMENS

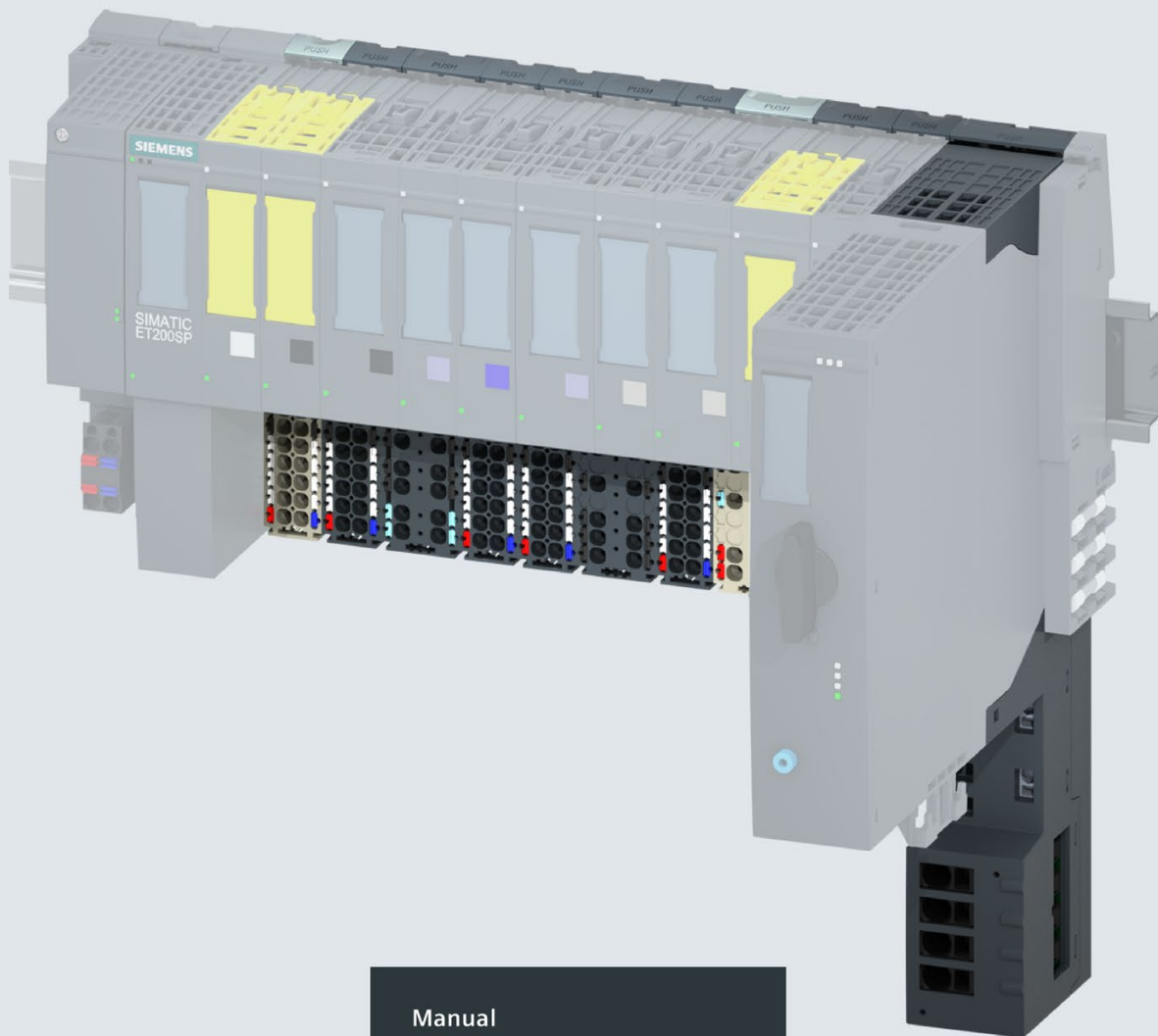

Manual

SIMATIC

ET 200SP

BaseUnits (6ES7193-6BP.../3RK1908-0AP00...)

Edition

02/2018

support.industry.siemens.com

SIEMENS

SIMATIC

ET 200SP
BaseUnits
(6ES7193-6BP.../3RK1908-0AP00...)

Manual

Preface

Guide to the documentation

1

New properties

2

Product overview

3

BaseUnits for I/O modules

4

BaseUnits for motor starters

5

Potential distributor modules

6

Dimension drawings of I/O
modules

A

Dimension drawings of motor
starters

B



Dimension drawings of the
potential distributor modules

7

Legal information

Warning notice system

This manual contains notices you have to observe in order to ensure your personal safety, as well as to prevent damage to property. The notices referring to your personal safety are highlighted in the manual by a safety alert symbol, notices referring only to property damage have no safety alert symbol. These notices shown below are graded according to the degree of danger.

 DANGER
indicates that death or severe personal injury will result if proper precautions are not taken.
 WARNING
indicates that death or severe personal injury may result if proper precautions are not taken.
 CAUTION
indicates that minor personal injury can result if proper precautions are not taken.
NOTICE
indicates that property damage can result if proper precautions are not taken.

If more than one degree of danger is present, the warning notice representing the highest degree of danger will be used. A notice warning of injury to persons with a safety alert symbol may also include a warning relating to property damage.

Qualified Personnel

The product/system described in this documentation may be operated only by **personnel qualified** for the specific task in accordance with the relevant documentation, in particular its warning notices and safety instructions. Qualified personnel are those who, based on their training and experience, are capable of identifying risks and avoiding potential hazards when working with these products/systems.

Proper use of Siemens products

Note the following:

 WARNING
Siemens products may only be used for the applications described in the catalog and in the relevant technical documentation. If products and components from other manufacturers are used, these must be recommended or approved by Siemens. Proper transport, storage, installation, assembly, commissioning, operation and maintenance are required to ensure that the products operate safely and without any problems. The permissible ambient conditions must be complied with. The information in the relevant documentation must be observed.

Trademarks

All names identified by ® are registered trademarks of Siemens AG. The remaining trademarks in this publication may be trademarks whose use by third parties for their own purposes could violate the rights of the owner.

Disclaimer of Liability

We have reviewed the contents of this publication to ensure consistency with the hardware and software described. Since variance cannot be precluded entirely, we cannot guarantee full consistency. However, the information in this publication is reviewed regularly and any necessary corrections are included in subsequent editions.

Preface

Purpose of the documentation

This manual supplements the system manual ET 200SP distributed I/O system (<http://support.automation.siemens.com/WW/view/en/58649293>). Functions affecting the system in general are described there.

The information provided in this manual and in the system/function manuals supports you in commissioning the system.

Conventions

Please also observe notes marked as follows:

Note

A note contains important information on the product described in the documentation, on the handling of the product and on the section of the documentation to which particular attention should be paid.

Changes compared to the previous version

In contrast to the previous version, the chapters "BaseUnits for motor starters" and "Dimension drawings for motor starters" have been added to this manual.

Recycling and disposal

For ecologically sustainable recycling and disposal of your old device, contact a certificated disposal service for electronic scrap and dispose of the device in accordance with the regulations in your country.

Security information

Siemens provides products and solutions with industrial security functions that support the secure operation of plants, systems, machines and networks.

In order to protect plants, systems, machines and networks against cyber threats, it is necessary to implement – and continuously maintain – a holistic, state-of-the-art industrial security concept. Siemens' products and solutions constitute one element of such a concept.

Customers are responsible for preventing unauthorized access to their plants, systems, machines and networks. Such systems, machines and components should only be connected to an enterprise network or the internet if and to the extent such a connection is necessary and only when appropriate security measures (e.g. firewalls and/or network segmentation) are in place.

For additional information on industrial security measures that may be implemented, please visit (<https://www.siemens.com/industrialsecurity>).

Siemens' products and solutions undergo continuous development to make them more secure. Siemens strongly recommends that product updates are applied as soon as they are available and that the latest product versions are used. Use of product versions that are no longer supported, and failure to apply the latest updates may increase customers' exposure to cyber threats.

To stay informed about product updates, subscribe to the Siemens Industrial Security RSS Feed under (<https://www.siemens.com/industrialsecurity>).

Table of contents

	Preface	3
1	Guide to the documentation	8
2	New properties.....	13
3	Product overview	14
4	BaseUnits for I/O modules	21
4.1	Product description	21
4.1.1	Introduction	21
4.2	BU type A0, light-colored version with AUX terminals	22
4.2.1	Product overview	22
4.2.2	Connecting up	23
4.2.3	Technical specifications	24
4.3	BU type A0, light-colored version without AUX terminals	26
4.3.1	Product overview	26
4.3.2	Connection	27
4.3.3	Technical specifications	28
4.4	BU type A0, dark-colored version, with AUX terminals	30
4.4.1	Product overview	30
4.4.2	Connection	31
4.4.3	Technical specifications	32
4.5	BU type A0, dark-colored version, without AUX terminals	34
4.5.1	Product overview	34
4.5.2	Connection	35
4.5.3	Technical specifications	36
4.6	BU type A1, light-colored version, with additional terminals	38
4.6.1	Product overview	38
4.6.2	Connection	40
4.6.3	Technical specifications	41
4.7	BU type A1, light-colored version, without additional terminals	43
4.7.1	Product overview	43
4.7.2	Connection	45
4.7.3	Technical specifications	46
4.8	BU type A1, dark-colored version, with additional terminals	48
4.8.1	Product overview	48
4.8.2	Connection	49
4.8.3	Technical specifications	50
4.9	BU type A1, dark-colored version, without additional terminals	52
4.9.1	Product overview	52
4.9.2	Connection	53
4.9.3	Technical specifications	54

4.10	BU type B0, dark-colored version, with AUX terminals, supply over P1, P2 busbar	56
4.10.1	Product overview.....	56
4.10.2	Connecting	57
4.10.3	Technical specifications	58
4.11	BU type B1, dark-colored version, without AUX terminals, supply over supply terminals	60
4.11.1	Product overview.....	60
4.11.2	Connecting up	61
4.11.3	Technical specifications	62
4.12	BU type C0, light-colored version, with AUX terminals, supply over supply terminals	64
4.12.1	Product overview.....	64
4.12.2	Connecting	66
4.12.3	Technical specifications	67
4.13	BU type C1, dark-colored version, with AUX terminals, supply over P1, P2 busbar	68
4.13.1	Product overview.....	68
4.13.2	Connecting	69
4.13.3	Technical specifications	70
4.14	BU type D0, dark-colored version, without AUX terminals, supply over supply terminals.....	72
4.14.1	Product overview.....	72
4.14.2	Connecting	73
4.14.3	Technical specifications	74
4.15	BU type F0, dark-colored version, with AUX terminals, supply over supply terminals	75
4.15.1	Product overview.....	75
4.15.2	Connecting up	76
4.15.3	Technical specifications	77
4.16	BU type U0, light-colored version without AUX terminals.....	79
4.16.1	Product overview.....	79
4.16.2	Connection	80
4.16.3	Technical specifications	81
4.17	BU type U0, dark-colored version, without AUX terminals	83
4.17.1	Product overview.....	83
4.17.2	Connection	84
4.17.3	Technical specifications	85
5	BaseUnits for motor starters.....	87
5.1	Introduction	87
5.2	BU30-MS1 - BaseUnit with 24 V DC and 500 V AC infeed	88
5.2.1	Product overview.....	88
5.2.2	Connection	89
5.2.3	Technical specifications	91
5.3	BU30-MS2 - BaseUnit with 500 V AC infeed	92
5.3.1	Product overview.....	92
5.3.2	Connection	93
5.3.3	Technical specifications	95

5.4	BU30-MS3 - BaseUnit with 24 V DC infeed.....	96
5.4.1	Product overview	96
5.4.2	Connection.....	97
5.4.3	Technical specifications	99
5.5	BU30-MS4 - BaseUnit without infeed	100
5.5.1	Product overview	100
5.5.2	Connection.....	101
5.5.3	Technical specifications	103
5.6	BU30-MS5 BaseUnit with 500 V AC infeed and F-DI.....	104
5.6.1	Product overview	104
5.6.2	Connection.....	106
5.6.3	Technical specifications	108
5.7	BU30-MS6 BaseUnit without infeed and with F-DI.....	109
5.7.1	Product overview	109
5.7.2	Connection.....	110
5.7.3	Technical specifications	112
6	Potential distributor modules	113
6.1	Introduction	113
6.2	PotDis-BU type P1, light-colored version.....	114
6.2.1	Short designation.....	114
6.2.2	Product overview	114
6.2.3	Connecting.....	115
6.2.4	Technical specifications	116
6.3	PotDis-BU type P1, dark-colored version	118
6.3.1	Product overview	118
6.3.2	Connecting.....	119
6.3.3	Technical specifications	120
6.4	PotDis-BU type P2, light-colored version.....	122
6.4.1	Short designation.....	122
6.4.2	Product overview	122
6.4.3	Connecting.....	123
6.4.4	Technical specifications	124
6.5	PotDis-BU type P2, dark-colored version	126
6.5.1	Short designation.....	126
6.5.2	Product overview	126
6.5.3	Connecting.....	127
6.5.4	Technical specifications	128
6.6	PotDis-TB.....	130
6.6.1	Product overview	130
6.6.2	Connecting.....	132
6.6.3	Technical specifications	133
A	Dimension drawings of I/O modules	141
B	Dimension drawings of motor starters	144
7	Dimension drawings of the potential distributor modules.....	145

Guide to the documentation

The documentation for the SIMATIC ET 200SP distributed I/O system is arranged into three areas.

This arrangement enables you to access the specific content you require.

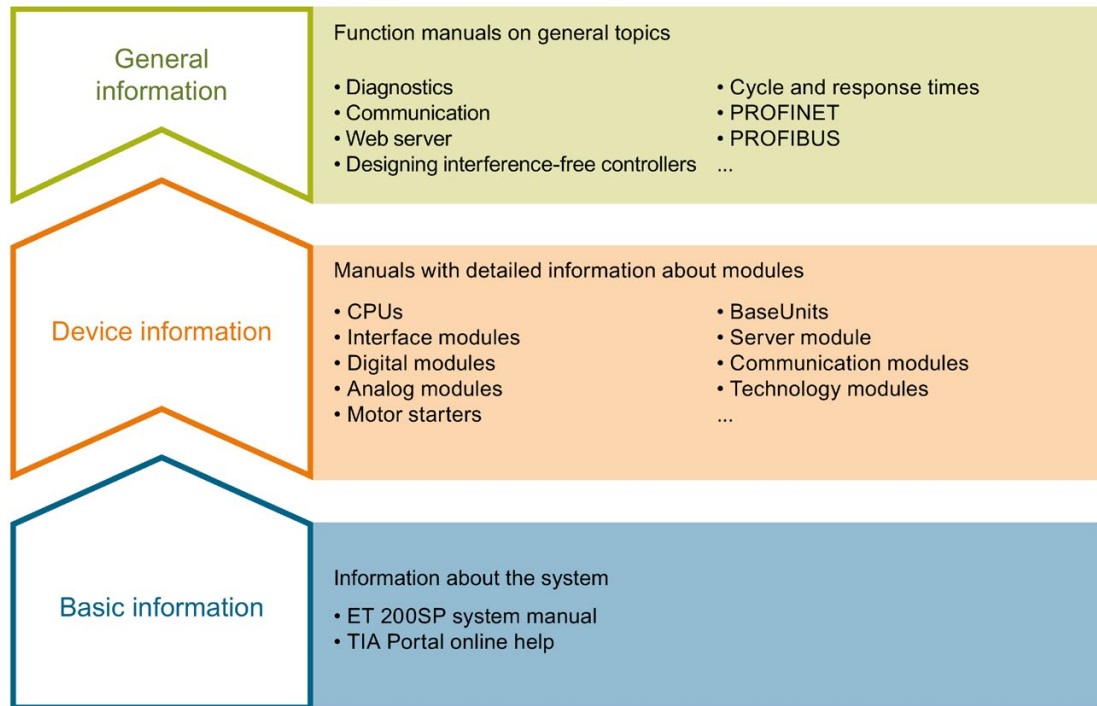

Basic information

The system manual describes in detail the configuration, installation, wiring and commissioning of the SIMATIC ET 200SP distributed I/O system. The STEP 7 online help supports you in the configuration and programming.

Device information

Product manuals contain a compact description of the module-specific information, such as properties, wiring diagrams, characteristics and technical specifications.

General information

The function manuals contain detailed descriptions on general topics regarding the SIMATIC ET 200SP distributed I/O system, e.g. diagnostics, communication, Web server, motion control and OPC UA.

You can download the documentation free of charge from the Internet (<https://support.industry.siemens.com/cs/ww/de/view/58649293>).

Changes and supplements to the manuals are documented in a Product Information.

You can download the product information free of charge from the Internet (<https://support.industry.siemens.com/cs/ww/de/view/109742709>).

Manual Collection ET 200SP

The Manual Collection contains the complete documentation on the SIMATIC ET 200SP distributed I/O system gathered together in one file.

You can find the Manual Collection on the Internet (<http://support.automation.siemens.com/WW/view/en/84133942>).

"mySupport"

With "mySupport", your personal workspace, you make the most of your Industry Online Support.

In "mySupport" you can store filters, favorites and tags, request CAx data and put together your personal library in the Documentation area. Furthermore, your data is automatically filled into support requests and you always have an overview of your current requests.

You need to register once to use the full functionality of "mySupport".

You can find "mySupport" in the Internet (<https://support.industry.siemens.com/My/ww/de/>).

"mySupport" - Documentation

In the Documentation area of "mySupport", you have the possibility to combine complete manuals or parts of them to make your own manual.

You can export the manual in PDF format or in an editable format.

You can find "mySupport" - Documentation in the Internet (<http://support.industry.siemens.com/My/ww/en/documentation>).

"mySupport" - CAx Data

In the CAx Data area of "mySupport", you can have access the latest product data for your CAx or CAe system.

You configure your own download package with a few clicks.

In doing so you can select:

- Product images, 2D dimension drawings, 3D models, internal circuit diagrams, EPLAN macro files
- Manuals, characteristics, operating manuals, certificates
- Product master data

You can find "mySupport" - CAx Data in the Internet (<http://support.industry.siemens.com/my/ww/en/CAxOnline>).

Application examples

The application examples support you with various tools and examples for solving your automation tasks. Solutions are shown in interplay with multiple components in the system - separated from the focus in individual products.

You can find the application examples on the Internet (<http://support.industry.siemens.com/cs/ww/en/ps/ae>).

TIA Selection Tool

With the TIA Selection Tool, you can select, configure and order devices for Totally Integrated Automation (TIA).

This tool is the successor of the SIMATIC Selection Tool and combines the known configurators for automation technology into one tool.

With the TIA Selection Tool, you can generate a complete order list from your product selection or product configuration.

You can find the TIA Selection Tool on the Internet (<http://w3.siemens.com/mcms/topics/en/simatic/tia-selection-tool>).

SIMATIC Automation Tool

You can use the SIMATIC Automation Tool to run commissioning and maintenance activities simultaneously on various SIMATIC S7 stations as a bulk operation independently of the TIA Portal.

The SIMATIC Automation Tool provides a multitude of functions:

- Scanning of a PROFINET/Ethernet network and identification of all connected CPUs
- Address assignment (IP, subnet, gateway) and station name (PROFINET device) to a CPU
- Transfer of the data and the programming device/PC time converted to UTC time to the module
- Program download to CPU
- Operating mode switchover RUN/STOP
- Localization of the CPU by means of LED flashing
- Reading out CPU error information
- Reading the CPU diagnostic buffer
- Reset to factory settings
- Updating the firmware of the CPU and connected modules

You can find the SIMATIC Automation Tool on the Internet (<https://support.industry.siemens.com/cs/ww/de/view/109751152>).

PRONETA

With SIEMENS PRONETA (PROFINET network analysis), you analyze the plant network during commissioning. PRONETA features two core functions:

- The topology overview independently scans PROFINET and all connected components.
- The IO check is a fast test of the wiring and the module configuration of a system.

You can find SIEMENS PRONETA on the Internet (<https://support.industry.siemens.com/cs/ww/de/view/67460624>).

SINETPLAN

SINETPLAN, the Siemens Network Planner, supports you in planning automation systems and networks based on PROFINET. The tool facilitates professional and predictive dimensioning of your PROFINET installation as early as in the planning stage. In addition, SINETPLAN supports you during network optimization and helps you to exploit network resources optimally and to plan reserves. This helps to prevent problems in commissioning or failures during productive operation even in advance of a planned operation. This increases the availability of the production plant and helps improve operational safety.

The advantages at a glance

- Network optimization thanks to port-specific calculation of the network load
- Increased production availability thanks to online scan and verification of existing systems
- Transparency before commissioning through importing and simulation of existing STEP 7 projects
- Efficiency through securing existing investments in the long term and optimal exploitation of resources

You can find SINETPLAN on the Internet

(<https://support.industry.siemens.com/cs/ww/de/view/109485570>).

New properties

What's new in the BaseUnits manual, edition 02/2018, compared to edition 12/2016?

What's new?		What are the customer benefits?	Where can I find information?
New contents	Potential distributor modules	<p>A system-integrated potential distribution can be implemented via the PotDis modules.</p> <p>One application is, for example, the design of digital input modules with 16 channels and three-wire connection. You use the potential distributor modules to reserve the unused signal cables of antivalent sensors.</p> <p>Another application is the supply of potentials for supply of external components.</p>	Section Potential distributor modules (Page 113)
	<p>BaseUnit type U0</p> <p>Can be used for all I/O modules whose article number ends in U0</p>	<p>Light-colored version: BU20-P16+A0+2D</p> <p>Per slot, up to 16 process terminals can be supplied to the module with max. 230 V/5 A per terminal.</p> <ul style="list-style-type: none"> • 2 supply terminals on integrated self-assembling voltage buses P1/P2, max. 230 V AC/10 A • Separation of voltage buses P1/P2 and AUX from the adjacent module on the left 	Section BU20-P16+A0+2D (Page 79)
		<p>Dark-colored version: BU20-P16+A0+2B</p> <p>Per slot, up to 16 process terminals can be supplied to the module with max. 230 V/5 A per terminal.</p> <ul style="list-style-type: none"> • 2 terminals for external supply/forwarding from integrated self-assembling voltage buses P1/P2 • Bridging voltage buses P1/P2 and AUX to the adjacent module on the left 	Section BU20-P16+A0+2B (Page 83)

Product overview

General properties of the BaseUnits

The ET 200SP distributed I/O system includes various BaseUnits. You use the BaseUnit to specify the following, for example:

- Process connection
- Plug-in I/O module/motor starter
- Infeed of supply voltage specified

You can recognize the properties of the BaseUnits from their short description:

Table 3- 1 Properties of the BaseUnits

Short description BU15-P16+A10+2D/T (example)			BaseUnit properties
Name/module width	BU	15	BaseUnit with width of 15 mm
		20	BaseUnit with width of 20 mm
		30	BaseUnit with width of 30 mm
Process connection	P	4	<ul style="list-style-type: none"> • Connection method: Push-in terminal • Number of terminals to the I/O module: 4
		8	<ul style="list-style-type: none"> • Connection method: Push-in terminal • Number of terminals to the I/O module: 8
		16	<ul style="list-style-type: none"> • Connection method: Push-in terminal • Number of terminals to the I/O module: 16
Connection to the AUX busbar	A	0	No connection to the AUX busbar
		10	n = number of AUX terminals, e.g. 10

Short description BU15-P16+A10+2D/T (example)		BaseUnit properties	
Self-assembling voltage buses	2	2 push-in terminals for supplying or tapping the supply voltage via the self-assembling voltage buses P1, P2 (see D, B)	
	12	<ul style="list-style-type: none"> 2 push-in terminals for supplying or tapping the supply voltage via the self-assembling voltage buses P1, P2 (see D, B) 2×5 push-in additional terminals (1 B to 5 B, 1 C to 5 C). For connecting further potential up to a maximum supply current of 24 V DC/10 A 	
	0	No terminals with access to the self-assembling voltage buses P1, P2	
		B	<ul style="list-style-type: none"> Looping through the potential group Tapping of the supply voltage for external components or looping through with a maximum total current of 10 A per potential group
		D	<ul style="list-style-type: none"> Opening a new potential group Feeding in of supply voltage up to a maximum supply current of 10 A
Additional functions	T	Integrated temperature sensor to compensate the reference junction temperature for thermocouples	

Properties of the BaseUnits for motor starters

The following table lists the properties of the individual BaseUnits for motor starters:

BaseUnit	Properties
BU30-MS1	<ul style="list-style-type: none"> • Push-in terminals for opening a new potential group (24 V DC). • Feeding in of supply voltage up to a maximum supply current of 7 A DC. • Opening a new supply voltage potential group (500 V AC) • Feeding in of supply voltage up to a maximum supply current of 32 A AC.
BU30-MS2	<ul style="list-style-type: none"> • Further conduction of the potential group (24 V DC) • Push-in terminals for opening a new supply voltage potential group (500 V AC) • Infeed of supply voltage up to a maximum supply current up to 32 A AC.
BU30-MS3	<ul style="list-style-type: none"> • Push-in terminals for opening a new potential group (24 V DC). • Infeed of the supply voltage L+ up to an infeed current of 7 A DC • Further conduction of the supply voltage potential group (500 V AC)
BU30-MS4	<ul style="list-style-type: none"> • Further conduction of the supply voltage potential group (500 V AC) • Further conduction of the potential group (24 V DC)
BU30-MS5	<ul style="list-style-type: none"> • Further conduction of the potential group (24 V DC) • Push-in terminals for opening a new supply voltage potential group (500 V AC) • Infeed of supply voltage up to a maximum supply current of 32 A AC • A fail-safe digital input
BU30-MS6	<ul style="list-style-type: none"> • Further conduction of the potential group (24 V DC) • Further conduction of the supply voltage potential group (500 V AC) • Push-In terminals • A fail-safe digital input

Properties of the potential distributor modules

The following table shows the properties of the individual potential distributor modules:

Table 3- 2 PotDis-BaseUnits properties

Short description PotDis-BU-P1/D-R (example)		PotDis-BaseUnit properties
Designation	PotDis-BU	PotDis-BaseUnit
Process connection (24 V DC / 10 A)	P1	Terminals for supplying or tapping the supply voltage with connection to the voltage bus P1 (see D, B)
	P2	Terminals for supplying or tapping the supply voltage with connection to the voltage bus P2 (see D, B)
Self-assembling voltage buses	D	<ul style="list-style-type: none"> Opening a new PotDis potential group Feeding in of supply voltage up to a maximum supply current up to 10 A Tapping the supply voltage for external components or looping with a maximum total current of 10 A per potential group
	B	<ul style="list-style-type: none"> Further conduction of the potential group Tapping the supply voltage for external components or looping with a maximum total current of 10 A per potential group
Color coding of the spring releases	R	Connection to the internal voltage bus P1 Red spring release
	B	Connection to the internal voltage bus P2 Blue spring release

Properties of the terminal blocks PotDis-TB

The following table shows the properties of the individual terminal blocks:

Table 3- 3 Properties of the PotDis-Terminalblocks

Short description PotDis-TB-P1-R (example)		PotDis-Terminalblock properties
Designation	PotDis-TB	PotDis terminal block
Process connection (24 V DC / 10 A)	P1	<ul style="list-style-type: none"> • Connection to the voltage bus P1 • Terminals for picking off the rated supply voltage 24 V DC with max. 10 A of the same voltage level
	P2	<ul style="list-style-type: none"> • Connection to the voltage bus P2 • Terminals for picking off the rated supply voltage 24 V DC with max. 10 A of the same voltage level
	n.c.	<ul style="list-style-type: none"> • No connection to the P1, P2 or AUX bus • Terminals can be used freely up to 230 V AC with max. 10 A
	BR	<ul style="list-style-type: none"> • No connection to the P1, P2 or AUX bus • Terminals for protective conductor connection or voltage bus (internal connected) freely usable up to 230 V AC with max. 10 A
Color coding of the spring releases	R	Red spring release
	B	Blue spring release
	W	White spring release
	G	Gray spring release

Selecting, installing and connecting BaseUnits

You can find additional information in the system manual ET 200SP Distributed I/O System (<http://support.automation.siemens.com/WW/view/en/58649293>).

WARNING

Personal injury or damage to equipment is possible.

Connecting a rated supply voltage to the BaseUnit higher than the one given in the technical specifications may lead to dangerous situations in your plant or cause defects in ET 200SP components.

Therefore, only connect the rated supply voltage given in the technical specifications to the BaseUnit.

The connected rated supply voltage must correspond to the rated supply voltage of the I/O modules in the potential group.

When mains voltage is connected to the BaseUnit, ensure that all other supply voltages on this BaseUnit use the same phase as the mains.

The Totally Integrated Automation Selection Tool (TIA Selection Tool) (<http://w3.siemens.com/mcms/topics/de/simatic/tia-selection-tool>) supports you in selecting, configuring and ordering the ET 200SP modules. The free TIA Selection Tool is available on the Internet (<http://support.automation.siemens.com/WW/view/en/58649293>).

WARNING

Hazardous Voltage (when using ET 200SP motor starters) Can Cause Death, Serious Injury, or Property Damage.

Proper use of hardware products

This equipment is only allowed to be used for the applications described in the catalog and in the technical description, and only in conjunction with non-Siemens equipment and components recommended by Siemens.

Correct transport, storage, installation and assembly, as well as careful operation and maintenance, are required to ensure that the product operates safely and without faults.

EU note: Start-up/commissioning is absolutely prohibited until it has been ensured that the machine in which the component described here is to be installed fulfills the regulations/specifications of Machinery Directive 2006/42/EC.

 **WARNING**

**Hazardous Voltage (when using ET 200SP motor starters)
Can Cause Death, Serious Injury, or Property Damage.**

Please take note of our latest information.

Systems with safety-related characteristics are subject to special operational safety requirements on the part of the operator. The supplier is also obliged to comply with special product monitoring measures. For this reason, we publish a special newsletter containing information on product developments and features that are (or could be) relevant to operation of safety-related systems. You need to subscribe to the corresponding newsletter to ensure that you always remain up-to-date and are able to make any necessary changes to your plant regarding operational safety should the need arise.

Siemens Newsletter (<http://www.industry.siemens.com/newsletter>)

Sign on to the following newsletter under "Products & Solutions":

- Control Components and System Engineering News
- Safety Integrated Newsletter

BaseUnits for I/O modules

4.1 Product description

4.1.1 Introduction

Properties of the BaseUnits

The ET 200SP distributed I/O system offers you a rugged and service-friendly design with permanent wiring over the BaseUnits (BU).

The BaseUnits provide the electrical and mechanical connection of the ET 200SP modules. A wide range of BaseUnits is available to suit individual requirements.

You can place BaseUnits at any location with the ET 200SP distributed I/O system. Thanks to the push-in connection system, you can wire the terminals without tools.

Note the following restrictions:

- The potential group based on SELV/PELV supply or the PotDis version is light-colored.
- The infeed of protective conductor via BU is not permitted.

You can find additional information on using the BaseUnit in the ET 200SP System Manual (<https://support.industry.siemens.com/cs/ww/en/view/58649293>).

Note

All BaseUnits placed in a load group must match the infeed potential of the corresponding light-colored BaseUnits.

4.2 BU type A0, light-colored version with AUX terminals

Short designation

Short designation: BU15-P16+A10+2D

4.2.1 Product overview

Delivery options (packing unit VPE)

6ES7193-6BP20-0DA0 (VPE: 1 unit)

6ES7193-6BP20-2DA0 (VPE: 10 units)

View

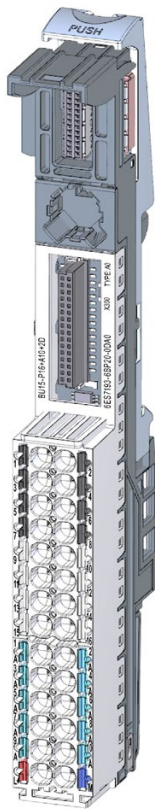

Figure 4-1 BU type A0, light-colored version with AUX terminals

Properties

- BaseUnit suitable for all I/O modules of the BaseUnit type "A0/A1". Can be recognized by the laser inscription on the front and/or the last two digits of the article number.
 - Supply voltage (L+ terminal, ground): Max. 24 V DC/10 A
 - Current-carrying capacity per process terminal (terminal 1 to 16): Max. 2 A
- The BaseUnit opens up a new potential group. The self-assembling voltage buses P1 and P2, and the AUX busbar are interrupted to the left-hand neighboring module (BaseUnit, interface module).
- Access to the AUX busbar via terminals
- 16 terminals to the process (assignment through the I/O module)
- 10 AUX terminals for connecting a protective conductor or potential. The AUX busbar is not connected to the I/O module. Max. 24 V DC/10 A
- Connection system in the form of push-in terminals Connection cross-sections are available in the ET 200SP System Manual (<https://support.industry.siemens.com/cs/ww/de/view/58649293>).

Maximum configuration per potential group

The number of I/O modules that can be used per potential group depends on the following factors:

1. Total power requirement of all I/O modules operated on this potential group
2. Total power requirement of all loads connected externally to this potential group

The total current calculated according to item 1. and item 2. must not exceed 10 A.

4.2.2 Connecting up

Pin assignment

Pin assignment for BaseUnit BU type A0, light-colored version with AUX terminals	
Terminal	Descriptions
1 to 16	Assignment is determined by the I/O module. You can find additional information in the I/O Module (http://support.automation.siemens.com/WW/view/en/55679691/133300) manual.
1 A, 2 A, 3 A, 4 A, 5 A, 6 A, 7 A, 8 A, 9 A, 10 A	Protective conductor connection or voltage bus freely usable up to 24 V DC with max. 10 A
L+ / M	L+: Rated supply voltage 24 V DC with max. 10 A M: Ground

Block diagram

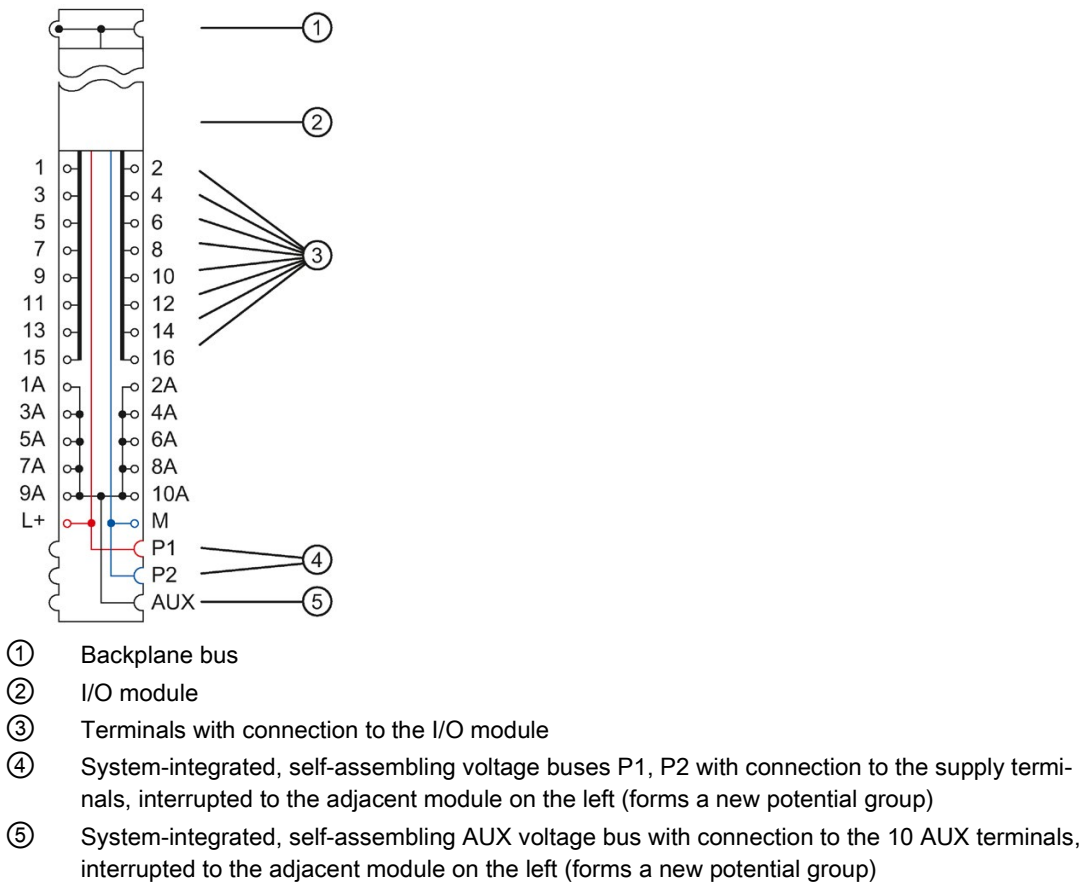

Figure 4-2 Block diagram of the BU type A0, light-colored version with AUX terminals

4.2.3 Technical specifications

Technical specifications of the BU-Typ A0, Variante hell mit AUX-Klemmen

Article number	6ES7193-6BP20-2DA0
General information	
Product type designation	Type A0
Supply voltage	
Rated value (DC)	24 V
external protection for power supply lines	Yes; 24 V DC/10 A miniature circuit breaker with type B or C tripping characteristic
Current carrying capacity	
For P1 and P2 bus, max.	10 A
For AUX bus, max.	10 A
For process terminals, max.	2 A

Article number	6ES7193-6BP20-2DA0
Hardware configuration	
Formation of potential groups	
• New potential group	Yes
• Potential group continued from the left	No
Potential separation	
between the potential groups	Yes
Isolation	
Isolation tested with	707 V DC (type test)
Accessories	
Color coding labels	
• for process terminals	CC00 to CC09
• for AUX terminals	CC71 to CC73
• for add-on terminals	does not exist
Connection method	
Terminals	
• Terminal type	Push-in terminal
• Conductor cross-section, min.	0.14 mm ² ; AWG 26
• Conductor cross-section, max.	2.5 mm ² ; AWG 14
• Number of process terminals to I/O module	16
• Number of terminals to AUX bus	0
• Number of add-on terminals	0
• Number of terminals with connection to P1 and P2 bus	2
Dimensions	
Width	15 mm
Height	141 mm
Depth	35 mm
Weights	
Weight, approx.	50 g

4.3 BU type A0, light-colored version without AUX terminals

Short designation

Short designation: BU15-P16+A0+2D

4.3.1 Product overview

Delivery options (packing unit VPE)

6ES7193-6BP00-0DA0 (VPE: 1 unit)

6ES7193-6BP00-2DA0 (VPE: 10 units)

View

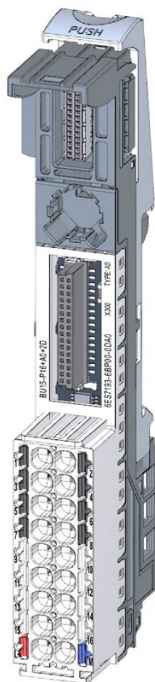

Figure 4-3 BU type A0, light-colored version, without AUX terminals

Properties

- BaseUnit suitable for all I/O modules of the BaseUnit type "A0/A1". Can be recognized by the laser inscription on the front and/or the last two digits of the article number.
 - Supply voltage (L+ terminal, ground): Max. 24 V DC/10 A
 - Current-carrying capacity per process terminal (terminal 1 to 16): Max. 2 A
- The BaseUnit opens up a new potential group. The self-assembling voltage buses P1 and P2, and the AUX busbar are interrupted to the left-hand neighboring module (BaseUnit, interface module).
- No access to the AUX busbar via terminals
- 16 terminals to the process (assignment through the I/O module)
- Connection system in the form of push-in terminals Connection cross-sections are available in the ET 200SP System Manual (<https://support.industry.siemens.com/cs/ww/de/view/58649293>).

Maximum configuration per potential group

The number of I/O modules that can be used per potential group depends on the following factors:

1. Total power requirement of all I/O modules operated on this potential group
2. Total power requirement of all loads connected externally to this potential group

The total current calculated according to item 1. and item 2. must not exceed 10 A.

4.3.2 Connection

Pin assignment

Pin assignment for BaseUnit BU type A0, light-colored version, without AUX terminals	
Terminal	Descriptions
1 to 16	Assignment is determined by the I/O module. You can find additional information in the I/O Module (http://support.automation.siemens.com/WW/view/en/55679691/133300) manual.
(AUX)	No access to the AUX busbar via terminals
L+ / M	L+: Rated supply voltage 24 V DC with max. 10 A M: Ground

Block diagram

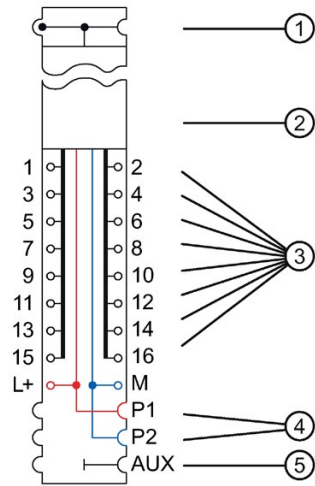

- ① Backplane bus
- ② I/O module
- ③ Terminals with connection to the I/O module
- ④ System-integrated, self-assembling voltage buses P1, P2 with connection to the supply terminals, interrupted to the adjacent module on the left (forms a new potential group)
- ⑤ System-integrated, self-assembling AUX voltage bus without connection to the AUX terminals, interrupted to the adjacent module on the left (forms a new potential group)

Figure 4-4 Block diagram of the BU type A0, light-colored version, without AUX terminals

4.3.3 Technical specifications

Technical specifications of the BaseUnit BU type A0, light-colored version, without AUX terminals

Article number	6ES7193-6BP20-2DA0
General information	
Product type designation	Type A0
Supply voltage	
Rated value (DC)	24 V
external protection for power supply lines	Yes; 24 V DC/10 A miniature circuit breaker with type B or C tripping characteristic
Current carrying capacity	
For P1 and P2 bus, max.	10 A
For AUX bus, max.	10 A
For process terminals, max.	2 A

Article number	6ES7193-6BP20-2DA0
Hardware configuration	
Formation of potential groups	
• New potential group	Yes
• Potential group continued from the left	No
Potential separation	
between the potential groups	Yes
Isolation	
Isolation tested with	707 V DC (type test)
Accessories	
Color coding labels	
• for process terminals	CC00 to CC09
• for AUX terminals	CC71 to CC73
• for add-on terminals	does not exist
Connection method	
Terminals	
• Terminal type	Push-in terminal
• Conductor cross-section, min.	0.14 mm ² ; AWG 26
• Conductor cross-section, max.	2.5 mm ² ; AWG 14
• Number of process terminals to I/O module	16
• Number of terminals to AUX bus	0
• Number of add-on terminals	0
• Number of terminals with connection to P1 and P2 bus	2
Dimensions	
Width	15 mm
Height	141 mm
Depth	35 mm
Weights	
Weight, approx.	50 g

4.4 BU type A0, dark-colored version, with AUX terminals

Short designation

Short designation: BU15-P16+A10+2B

4.4.1 Product overview

Delivery options (packing unit VPE)

6ES7193-6BP20-0BA0 (VPE: 1 unit)

6ES7193-6BP20-2BA0 (VPE: 10 units)

View

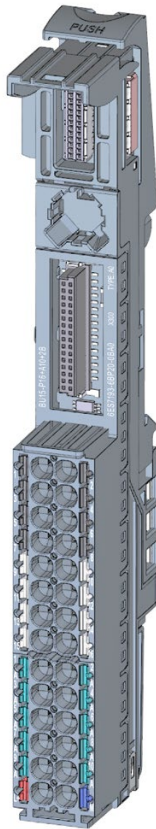

Figure 4-5 BU type A0, dark-colored version, with AUX terminals

Properties

- BaseUnit suitable for all I/O modules of the BaseUnit type "A0/A1". Can be recognized by the laser inscription on the front and/or the last two digits of the article number.
 - Current-carrying capacity per process terminal (terminal 1 to 16): Max. 2 A
- The BaseUnit conducts the potential group further. The self-assembling voltage buses P1 and P2, and the AUX busbar are connected to the left-hand neighboring module (BaseUnit).
- Access to the AUX busbar via terminals
- 16 terminals to the process (assignment through the I/O module)
- 10 AUX terminals for connecting a protective conductor or potential. The AUX busbar is not connected to the I/O module. Max. 24 V DC/10 A
- Connection system in the form of push-in terminals Connection cross-sections are available in the ET 200SP System Manual (<https://support.industry.siemens.com/cs/ww/de/view/58649293>).

4.4.2 Connection

Pin assignment

Pin assignment for BU type A0, dark-colored version, with AUX terminals	
Terminal	Descriptions
1 to 16	Assignment is determined by the I/O module. You can find additional information in the I/O Module (http://support.automation.siemens.com/WW/view/en/55679691/133300) manual.
1 A, 2 A, 3 A, 4 A, 5 A, 6 A, 7 A, 8 A, 9 A, 10 A, AUX	Protective conductor connection or voltage bus freely usable up to 24 V DC with max. 10 A
L+ / M	L+: Rated supply voltage 24 V DC with max. 10 A M: Ground

Block diagram

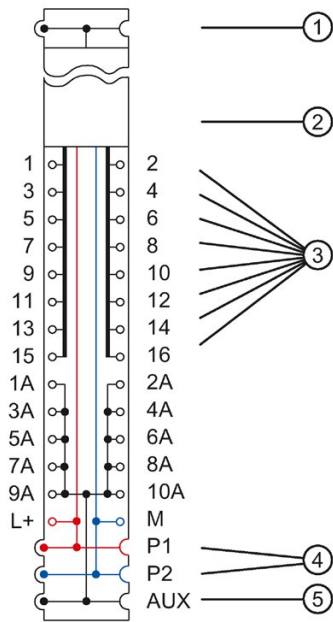

- ① Backplane bus
- ② I/O module
- ③ Terminals with connection to the I/O module
- ④ System-integrated, self-assembling voltage buses P1, P2 with connection to the supply terminals, connected to the adjacent module on the left
- ⑤ System-integrated, self-assembling AUX voltage bus with connection to the 10 AUX terminals, connected to the adjacent module on the left

Figure 4-6 Block diagram of the BU type A0, dark-colored version, with AUX terminals

4.4.3 Technical specifications

Technical specifications of the BU type A0, dark-colored version, with AUX terminals

Article number	6ES7193-6BP20-0BA0
General information	
Product type designation	Type A0
Supply voltage	
Rated value (DC)	24 V
external protection for power supply lines	Yes; 24 V DC/10 A miniature circuit breaker with type B or C tripping characteristic
Current carrying capacity	
For P1 and P2 bus, max.	10 A
For AUX bus, max.	10 A
For process terminals, max.	2 A

Article number	6ES7193-6BP20-0BA0
Hardware configuration	
Formation of potential groups	
<ul style="list-style-type: none"> • New potential group 	No
<ul style="list-style-type: none"> • Potential group continued from the left 	Yes
Isolation	
Isolation tested with	707 V DC (type test)
Accessories	
Color coding labels	
<ul style="list-style-type: none"> • for process terminals 	CC00 to CC09
<ul style="list-style-type: none"> • for AUX terminals 	CC71 to CC73
<ul style="list-style-type: none"> • for add-on terminals 	does not exist
Connection method	
Terminals	
<ul style="list-style-type: none"> • Terminal type 	Push-in terminal
<ul style="list-style-type: none"> • Conductor cross-section, min. 	0.14 mm ² ; AWG 26
<ul style="list-style-type: none"> • Conductor cross-section, max. 	2.5 mm ² ; AWG 14
<ul style="list-style-type: none"> • Number of process terminals to I/O module 	16
<ul style="list-style-type: none"> • Number of terminals to AUX bus 	0
<ul style="list-style-type: none"> • Number of add-on terminals 	0
<ul style="list-style-type: none"> • Number of terminals with connection to P1 and P2 bus 	2
Dimensions	
Width	15 mm
Height	141 mm
Depth	35 mm
Weights	
Weight, approx.	50 g

4.5 BU type A0, dark-colored version, without AUX terminals

Short designation

Short designation: BU15-P16+A0+2B

4.5.1 Product overview

Delivery options (packing unit VPE)

6ES7193-6BP00-0BA0 (VPE: 1 unit)

6ES7193-6BP00-2BA0 (VPE: 10 units)

View

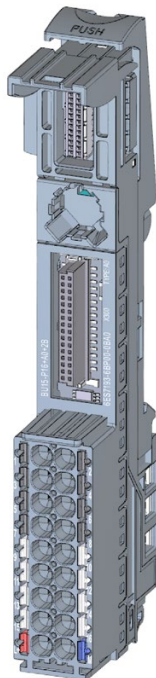

Figure 4-7 BU type A0, dark-colored version, without AUX terminals

Properties

- BaseUnit suitable for all I/O modules of the BaseUnit type "A0/A1". Can be recognized by the laser inscription on the front and/or the last two digits of the article number.
 - Current-carrying capacity per process terminal (terminal 1 to 16): Max. 2 A
- The BaseUnit conducts the potential group further. The self-assembling voltage buses P1 and P2, and the AUX busbar are connected to the left-hand neighboring module (BaseUnit).
- No access to the AUX busbar via terminals
- 16 terminals to the process (assignment through the I/O module)
- Connection system in the form of push-in terminals Connection cross-sections are available in the ET 200SP System Manual (<https://support.industry.siemens.com/cs/ww/de/view/58649293>).

4.5.2 Connection

Pin assignment

Pin assignment for BU type A0, dark-colored version, without AUX terminals	
Terminal	Descriptions
1 to 16	Assignment is determined by the I/O module. You can find additional information in the I/O Module (http://support.automation.siemens.com/WW/view/en/55679691/133300) manual.
(AUX)	No access to the AUX busbar via terminals
L+ / M	L+: Rated supply voltage 24 V DC with max. 10 A M: Ground

Block diagram

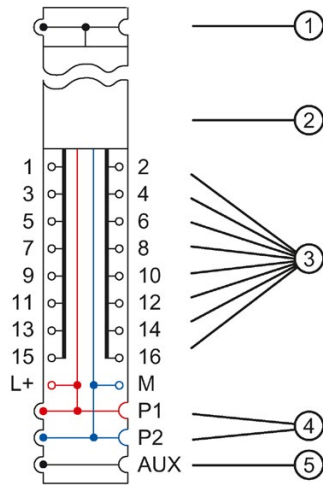

- ① Backplane bus
- ② I/O module
- ③ Terminals with connection to the I/O module
- ④ System-integrated, self-assembling voltage buses P1, P2 with connection to the supply terminals, connected to the adjacent module on the left
- ⑤ System-integrated, self-assembling AUX voltage bus without connection to the AUX terminals, connected to the adjacent module on the left

Figure 4-8 Block diagram of the BU type A0, dark-colored version, without AUX terminals

4.5.3 Technical specifications

Technical specifications of the BU type A0, dark-colored version, without AUX terminals

Article number	6ES7193-6BP00-0BA0
General information	
Product type designation	BU type A0, dark version, without AUX terminals, PU 1
Supply voltage	
Rated value (DC)	24 V
external protection for power supply lines	Yes; 24 V DC/10 A miniature circuit breaker with type B or C tripping characteristic
Current carrying capacity	
For P1 and P2 bus, max.	10 A
For process terminals, max.	2 A
Hardware configuration	
Formation of potential groups	
• New potential group	No
• Potential group continued from the left	Yes

Article number	6ES7193-6BP00-0BA0
Isolation	
Isolation tested with	707 V DC (type test)
Accessories	
Color coding labels	
<ul style="list-style-type: none"> for process terminals 	CC00 to CC09
<ul style="list-style-type: none"> for AUX terminals 	does not exist
<ul style="list-style-type: none"> for add-on terminals 	does not exist
Connection method	
Terminals	
<ul style="list-style-type: none"> Terminal type 	Push-in terminal
<ul style="list-style-type: none"> Conductor cross-section, min. 	0.14 mm ² ; AWG 26
<ul style="list-style-type: none"> Conductor cross-section, max. 	2.5 mm ² ; AWG 14
<ul style="list-style-type: none"> Number of process terminals to I/O module 	16
<ul style="list-style-type: none"> Number of terminals to AUX bus 	0
<ul style="list-style-type: none"> Number of add-on terminals 	0
<ul style="list-style-type: none"> Number of terminals with connection to P1 and P2 bus 	2
Dimensions	
Width	15 mm
Height	117 mm
Depth	35 mm
Weights	
Weight, approx.	40 g

4.6 BU type A1, light-colored version, with additional terminals

Short designation

Short designation: BU15-P16+A0+12D/T

4.6.1 Product overview

Delivery options (packing unit VPE)

6ES7193-6BP40-0DA1 (VPE: 1 unit)

View

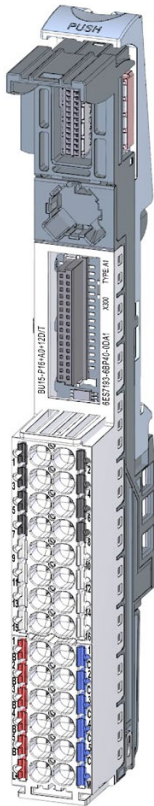

Figure 4-9 BU type A1, light-colored version, with additional terminals

Properties

- BaseUnit for all I/O modules of BaseUnit type "A1". Can be recognized by the laser inscription on the front and/or the last two digits of the article number.

Note

Using another I/O module can trigger an internal, non-exchangeable fuse and you must exchange the terminal box.

- Supply voltage (L+ terminal, ground): Max. 24 V DC/10 A
- Current-carrying capacity per process terminal (terminal 1 to 16): Max. 2 A
- The BaseUnit opens up a new potential group. The self-assembling voltage buses P1 and P2, and the AUX busbar are interrupted to the left-hand neighboring module (BaseUnit, interface module).
- No access to the AUX busbar via terminals
- 16 terminals to the process (assignment through the I/O module)
- 2x5 additional terminals for supplying a supply voltage up to 24 V DC/ 10 A. The additional terminals are not connected to the I/O module.
- Recording of the terminal temperature for internal temperature compensation at connected thermocouples
- Connection system in the form of push-in terminals Connection cross-sections are available in the ET 200SP System Manual (<https://support.industry.siemens.com/cs/ww/de/view/58649293>).

Maximum configuration per potential group

The number of I/O modules that can be used per potential group depends on the following factors:

1. Total power requirement of all I/O modules operated on this potential group
2. Total power requirement of all loads connected externally to this potential group

The total current calculated according to item 1. and item 2. must not exceed 10 A.

4.6.2 Connection

Pin assignment

Pin assignment for BU type A1, light-colored version, with additional terminals	
Terminal	Descriptions
1 to 16	Assignment is determined by the I/O module. You can find additional information in the I/O Module (http://support.automation.siemens.com/WW/view/en/55679691/133300) manual.
1 B, 2 B, 3 B, 4 B, 5 B / 1 C, 2 C, 3 C, 4 C, 5 C	2 x 5 add-on terminals for the infeed of a supply voltage up to 24 V DC with max. 10 A
(AUX)	No access to the AUX busbar via terminals
L+ / M	L+: Rated supply voltage 24 V DC with max. 10 A M: Ground

Block diagram

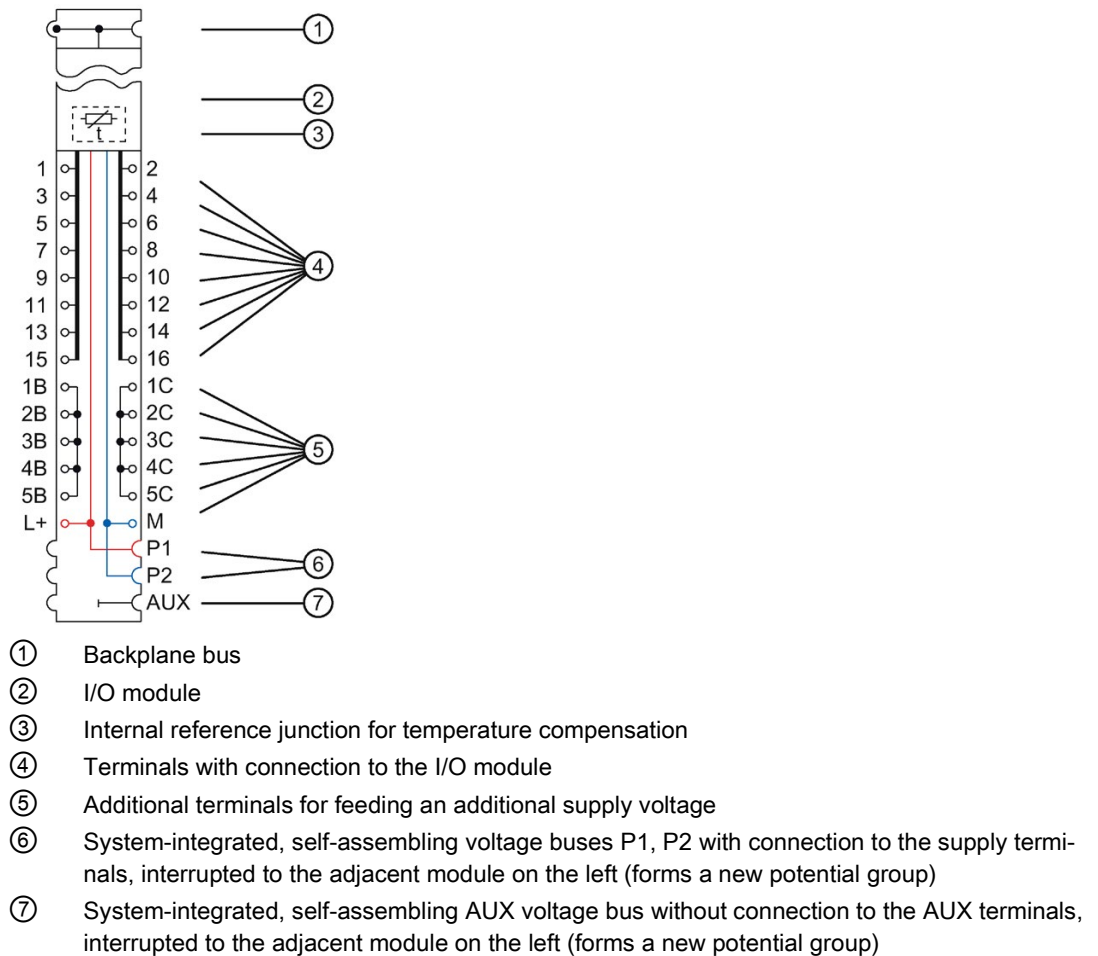

Figure 4-10 Block diagram of the BU type A1, light-colored version, with additional terminals

4.6.3 Technical specifications

Technical specifications of the BU type A1, light-colored version, with additional terminals

Article number	6ES7193-6BP40-0DA1
General information	
Product type designation	Type A1
Supply voltage	
Rated value (DC)	24 V
external protection for power supply lines	Yes; 24 V DC/10 A miniature circuit breaker with type B or C tripping characteristic

Article number	6ES7193-6BP40-0DA1
Current carrying capacity	
For P1 and P2 bus, max.	10 A
For process terminals, max.	2 A
Hardware configuration	
Additional terminals	Yes
Temperature sensor	Yes
Formation of potential groups	
<ul style="list-style-type: none"> New potential group 	Yes
<ul style="list-style-type: none"> Potential group continued from the left 	No
Potential separation	
between the potential groups	Yes
Isolation	
Isolation tested with	707 V DC (type test)
Accessories	
Color coding labels	
<ul style="list-style-type: none"> for process terminals 	CC00 to CC09
<ul style="list-style-type: none"> for AUX terminals 	does not exist
<ul style="list-style-type: none"> for add-on terminals 	CC74
Connection method	
Terminals	
<ul style="list-style-type: none"> Terminal type 	Push-in terminal
<ul style="list-style-type: none"> Conductor cross-section, min. 	0.14 mm ² ; AWG 26
<ul style="list-style-type: none"> Conductor cross-section, max. 	2.5 mm ² ; AWG 14
<ul style="list-style-type: none"> Number of process terminals to I/O module 	16
<ul style="list-style-type: none"> Number of terminals to AUX bus 	0
<ul style="list-style-type: none"> Number of add-on terminals 	0
<ul style="list-style-type: none"> Number of terminals with connection to P1 and P2 bus 	2
Dimensions	
Width	15 mm
Height	141 mm
Depth	35 mm
Weights	
Weight, approx.	50 g

4.7 BU type A1, light-colored version, without additional terminals

Short designation

Short designation: BU15-P16+A0+2D/T

4.7.1 Product overview

Delivery options (packing unit VPE)

6ES7193-6BP00-0DA1 (VPE: 1 unit)

View

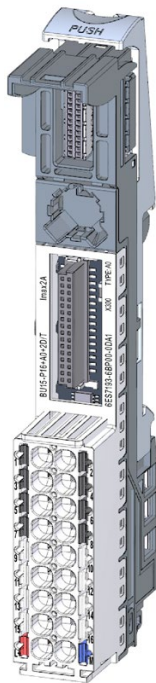

Figure 4-11 BU type A1, light-colored version, without additional terminals

Properties

- BaseUnit for all I/O modules of BaseUnit type "A1". Can be recognized by the laser inscription on the front and/or the last two digits of the article number.

Note

Using another I/O module can trigger an internal, non-exchangeable fuse and you must exchange the terminal box.

- Supply voltage (L+ terminal, ground): Max. 24 V DC/10 A
- Current-carrying capacity per process terminal (terminal 1 to 16): Max. 2 A
- The BaseUnit opens up a new potential group. The self-assembling voltage buses P1 and P2, and the AUX busbar are interrupted to the left-hand neighboring module (BaseUnit, interface module).
- No access to the AUX busbar via terminals
- 16 terminals to the process (assignment through the I/O module)
- Recording of the terminal temperature for internal temperature compensation at connected thermocouples
- Connection system in the form of push-in terminals Connection cross-sections are available in the ET 200SP System Manual (<https://support.industry.siemens.com/cs/ww/de/view/58649293>).

Maximum configuration per potential group

The number of I/O modules that can be used per potential group depends on the following factors:

1. Total power requirement of all I/O modules operated on this potential group
2. Total power requirement of all loads connected externally to this potential group

The total current calculated according to item 1. and item 2. must not exceed 10 A.

4.7.2 Connection

Pin assignment

Pin assignment for BU type A1, light-colored version, without additional terminals	
Terminal	Descriptions
1 to 16	Assignment is determined by the I/O module. You can find additional information in the I/O Module manual (http://support.automation.siemens.com/WW/view/en/55679691/133300)
(AUX)	No access to the AUX busbar via terminals
L+, P1 / M, P2	L+: Rated supply voltage 24 V DC with max. 10 A M: Ground

Block diagram

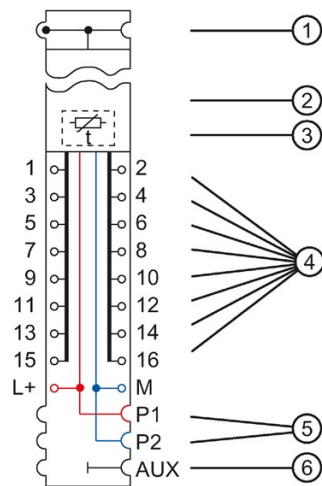

- ① Backplane bus
- ② I/O module
- ③ Internal reference junction for temperature compensation
- ④ Terminals with connection to the I/O module
- ⑤ System-integrated, self-assembling voltage buses P1, P2 with connection to the supply terminals, interrupted to the adjacent module on the left (forms a new potential group)
- ⑥ System-integrated, self-assembling AUX voltage bus without connection to the AUX terminals, interrupted to the adjacent module on the left (forms a new potential group)

Figure 4-12 Block diagram of the BU type A1, light-colored version, without additional terminals

4.7.3 Technical specifications

Technical specifications of the BU type A1, light-colored version, without additional terminals

Article number	6ES7193-6BP00-0DA1
General information	
Product type designation	Type A1
Supply voltage	
Rated value (DC)	24 V
external protection for power supply lines	Yes; 24 V DC/10 A miniature circuit breaker with type B or C tripping characteristic
Current carrying capacity	
For P1 and P2 bus, max.	10 A
For process terminals, max.	2 A
Hardware configuration	
Temperature sensor	Yes
Formation of potential groups	
• New potential group	Yes
• Potential group continued from the left	No
Potential separation	
between the potential groups	Yes
Isolation	
Isolation tested with	707 V DC (type test)
Accessories	
Color coding labels	
• for process terminals	CC00 to CC09
• for AUX terminals	does not exist
• for add-on terminals	does not exist
Connection method	
Terminals	
• Terminal type	Push-in terminal
• Conductor cross-section, min.	0.14 mm ² ; AWG 26
• Conductor cross-section, max.	2.5 mm ² ; AWG 14
• Number of process terminals to I/O module	16
• Number of terminals to AUX bus	0
• Number of add-on terminals	0
• Number of terminals with connection to P1 and P2 bus	2

Article number	6ES7193-6BP00-0DA1
Dimensions	
Width	15 mm
Height	117 mm
Depth	35 mm
Weights	
Weight, approx.	40 g

4.8 BU type A1, dark-colored version, with additional terminals

Short designation

Short designation: BU15-P16+A0+12B/T

4.8.1 Product overview

Delivery options (packing unit VPE)

6ES7193-6BP40-0BA1 (VPE: 1 unit)

View

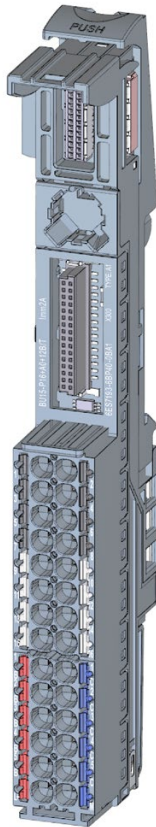

Figure 4-13 BU type A1, dark-colored version, with additional terminals

Properties

- BaseUnit suitable for all I/O modules of BaseUnit type "A1". Can be recognized by the laser inscription on the front and/or the last two digits of the article number.

Note

Using another I/O module can trigger an internal, non-exchangeable fuse and you must exchange the terminal box.

- Current-carrying capacity per process terminal (terminal 1 to 16): Max. 2 A
- The BaseUnit conducts the potential group further. The self-assembling voltage buses P1 and P2, and the AUX busbar are connected to the left-hand neighboring module (BaseUnit).
- No access to the AUX busbar via terminals
- 16 terminals to the process (assignment through the I/O module)
- 2x5 additional terminals for supplying a supply voltage up to 24 V DC/ 10 A. The additional terminals are not connected to the I/O module.
- Recording of the terminal temperature for internal temperature compensation at connected thermocouples
- Connection system in the form of push-in terminals Connection cross-sections are available in the ET 200SP System Manual (<https://support.industry.siemens.com/cs/ww/de/view/58649293>).

4.8.2 Connection

Pin assignment

Pin assignment for BU type A1, dark-colored version, with additional terminals	
Terminal	Descriptions
1 to 16	Assignment is determined by the I/O module. You can find additional information in the I/O Module (http://support.automation.siemens.com/WW/view/en/55679691/133300) manual.
1 B, 2 B, 3 B, 4 B, 5 B / 1 C, 2 C, 3 C, 4 C, 5 C	2 x 5 add-on terminals for the infeed of a supply voltage up to 24 V DC with max. 10 A
(AUX)	No access to the AUX busbar via terminals
L+, P1 / M, P2	L+: Rated supply voltage 24 V DC with max. 10 A M: Ground

Block diagram

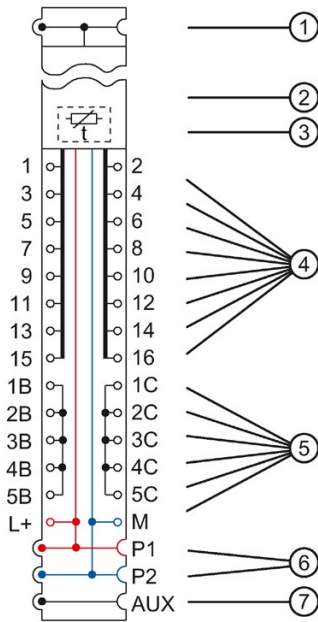

- ① Backplane bus
- ② I/O module
- ③ Internal reference junction for temperature compensation
- ④ Terminals with connection to the I/O module
- ⑤ Additional terminals for feeding an additional supply voltage
- ⑥ System-integrated, self-assembling voltage buses P1, P2 with connection to the supply terminals, connected to the adjacent module on the left
- ⑦ System-integrated, self-assembling AUX voltage bus without connection to the AUX terminals, connected to the adjacent module on the left

Figure 4-14 Block diagram of the BU type A1, dark-colored version, with additional terminals

4.8.3 Technical specifications

Technical specifications of the BU type A1, dark-colored version, with additional terminals

Article number	6ES7193-6BP40-0BA1
General information	
Product type designation	Type A1
Supply voltage	
Rated value (DC)	24 V
external protection for power supply lines	Yes; 24 V DC/10 A miniature circuit breaker with type B or C tripping characteristic

Article number	6ES7193-6BP40-0BA1
Current carrying capacity	
For P1 and P2 bus, max.	10 A
For process terminals, max.	2 A
Hardware configuration	
Additional terminals	Yes
Temperature sensor	Yes
Formation of potential groups	
<ul style="list-style-type: none"> New potential group 	No
<ul style="list-style-type: none"> Potential group continued from the left 	Yes
Isolation	
Isolation tested with	707 V DC (type test)
Accessories	
Color coding labels	
<ul style="list-style-type: none"> for process terminals 	CC00 to CC09
<ul style="list-style-type: none"> for AUX terminals 	does not exist
<ul style="list-style-type: none"> for add-on terminals 	CC74
Connection method	
Terminals	
<ul style="list-style-type: none"> Terminal type 	Push-in terminal
<ul style="list-style-type: none"> Conductor cross-section, min. 	0.14 mm ² ; AWG 26
<ul style="list-style-type: none"> Conductor cross-section, max. 	2.5 mm ² ; AWG 14
<ul style="list-style-type: none"> Number of process terminals to I/O module 	16
<ul style="list-style-type: none"> Number of terminals to AUX bus 	0
<ul style="list-style-type: none"> Number of add-on terminals 	0
<ul style="list-style-type: none"> Number of terminals with connection to P1 and P2 bus 	2
Dimensions	
Width	15 mm
Height	141 mm
Depth	35 mm
Weights	
Weight, approx.	50 g

4.9 BU type A1, dark-colored version, without additional terminals

Short designation

Short designation: BU15-P16+A0+2B/T

4.9.1 Product overview

Delivery options (packing unit VPE)

6ES7193-6BP00-0BA1 (VPE: 1 unit)

View

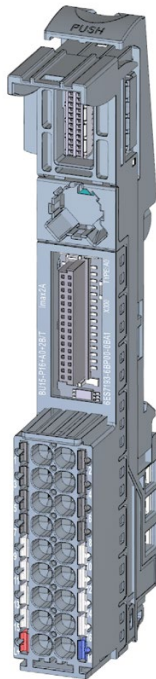

Figure 4-15 BU type A1, dark-colored version, without additional terminals

Properties

- BaseUnit suitable for all I/O modules of BaseUnit type "A1". Can be recognized by the laser inscription on the front and/or the last two digits of the article number.

Note

Using another I/O module can trigger an internal, non-exchangeable fuse and you must exchange the terminal box.

- Current-carrying capacity per process terminal (terminal 1 to 16): Max. 2 A
- The BaseUnit conducts the potential group further. The self-assembling voltage buses P1 and P2, and the AUX busbar are connected to the left-hand neighboring module (BaseUnit).
- No access to the AUX busbar via terminals
- 16 terminals to the process (assignment through the I/O module)
- Recording of the terminal temperature for internal temperature compensation at connected thermocouples
- Connection system in the form of push-in terminals Connection cross-sections are available in the ET 200SP System Manual (<https://support.industry.siemens.com/cs/ww/de/view/58649293>).

4.9.2 Connection

Pin assignment

Pin assignment for BU type A1, dark-colored version, without additional terminals	
Terminal	Descriptions
1 to 16	Assignment is determined by the I/O module. You can find additional information in the I/O Module manual. (http://support.automation.siemens.com/WW/view/en/55679691/133300)
(AUX)	No access to the AUX busbar via terminals
L+, P1 / M, P2	L+: Rated supply voltage 24 V DC with max. 10 A M: Ground

Block diagram

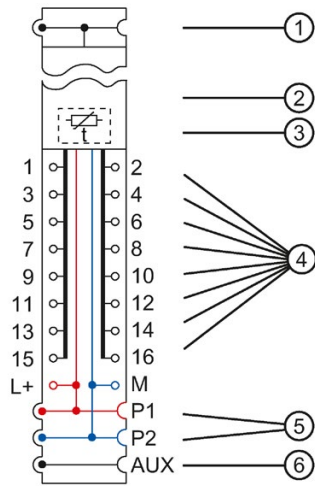

- ① Backplane bus
- ② I/O module
- ③ Internal reference junction for temperature compensation
- ④ Terminals with connection to the I/O module
- ⑤ System-integrated, self-assembling voltage buses P1, P2 with connection to the supply terminals, connected to the adjacent module on the left
- ⑥ System-integrated, self-assembling AUX voltage bus without connection to the AUX terminals, connected to the adjacent module on the left

Figure 4-16 Block diagram of the BU type A1, dark-colored version, without additional terminals

4.9.3 Technical specifications

Technical specifications of the BU type A1, dark-colored version, without additional terminals

Article number	6ES7193-6BP00-0BA1
General information	
Product type designation	Type A1
Supply voltage	
Rated value (DC)	24 V
external protection for power supply lines	Yes; 24 V DC/10 A miniature circuit breaker with type B or C tripping characteristic
Current carrying capacity	
For P1 and P2 bus, max.	10 A
For process terminals, max.	2 A
Hardware configuration	
Temperature sensor	Yes

Article number	6ES7193-6BP00-0BA1
Formation of potential groups	
<ul style="list-style-type: none"> New potential group 	No
<ul style="list-style-type: none"> Potential group continued from the left 	Yes
Isolation	
Isolation tested with	707 V DC (type test)
Accessories	
Color coding labels	
<ul style="list-style-type: none"> for process terminals 	CC00 to CC09
<ul style="list-style-type: none"> for AUX terminals 	does not exist
<ul style="list-style-type: none"> for add-on terminals 	does not exist
Connection method	
Terminals	
<ul style="list-style-type: none"> Terminal type 	Push-in terminal
<ul style="list-style-type: none"> Conductor cross-section, min. 	0.14 mm ² ; AWG 26
<ul style="list-style-type: none"> Conductor cross-section, max. 	2.5 mm ² ; AWG 14
<ul style="list-style-type: none"> Number of process terminals to I/O module 	16
<ul style="list-style-type: none"> Number of terminals to AUX bus 	0
<ul style="list-style-type: none"> Number of add-on terminals 	0
<ul style="list-style-type: none"> Number of terminals with connection to P1 and P2 bus 	2
Dimensions	
Width	15 mm
Height	117 mm
Depth	35 mm
Weights	
Weight, approx.	40 g

4.10 BU type B0, dark-colored version, with AUX terminals, supply over P1, P2 busbar

Short designation

Short designation: BU20-P12+A4+0B

4.10.1 Product overview

Delivery options (packing unit VPE)

6ES7193-6BP20-0BB0 (VPE: 1 unit)

6ES7193-6BP20-2BB0 (VPE: 10 units)

View

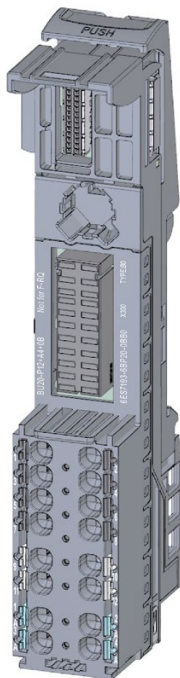

Figure 4-17 BU type B0, dark-colored version, with AUX terminals, supply over P1, P2 busbar

4.10 BU type B0, dark-colored version, with AUX terminals, supply over P1, P2 busbar

Properties

- BaseUnit suitable for all I/O modules of the BaseUnit type "B0/B1". Can be recognized by the laser inscription on the front and/or the last two digits of the article number.
 - Current-carrying capacity per process terminal (terminal 1 to 12): Max. 5 A
- The BaseUnit conducts the potential group further. The self-assembling voltage buses P1 and P2, and the AUX busbar are connected to the left-hand neighboring module (BaseUnit).
- Access to the AUX busbar via terminals
- 12 terminals to the process (assignment with the I/O module)
- Connection system in the form of push-in terminals Connection cross-sections are available in the ET 200SP System Manual (<https://support.industry.siemens.com/cs/ww/de/view/58649293>).

4.10.2 Connecting

Pin assignment

Pin assignment for BU type B0, dark-colored version, with AUX terminals, supply over P1, P2 busbar	
Terminal	Descriptions
1 to 12	Assignment is determined by the I/O module. You can find additional information in the I/O Module (http://support.automation.siemens.com/WWW/view/en/55679691/133300) manual.
1 A, 2 A, 3 A, 4 A, AUX	Protective conductor connection or voltage bus. Freely usable up to 230 V AC/DC with max 10 A. If you connect a voltage, it must belong to the same potential group as the rated supply voltage.

Block diagram

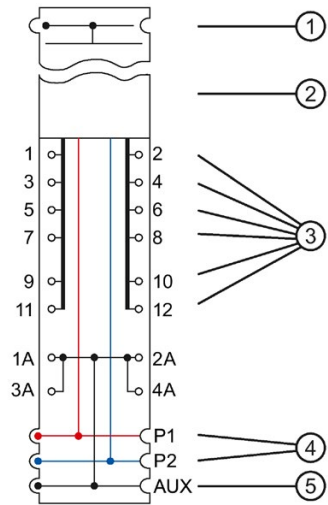

- ① Backplane bus
- ② I/O module
- ③ Terminals with connection to the I/O module
- ④ System-integrated, self-assembling voltage buses P1, P2 with connection to the supply terminals, connected to the adjacent module on the left
- ⑤ System-integrated, self-assembling AUX voltage bus with connection to the 4 AUX terminals, connected to the adjacent module on the left

Figure 4-18 Block diagram of the BU type B0, dark-colored version, with AUX terminals, supply over P1, P2 busbar

4.10.3 Technical specifications

Technical specifications of the BU type B0, dark-colored version, with AUX terminals, supply over P1, P2 busbar

Article number	6ES7193-6BP20-0BB0
General information	
Product type designation	Type B0
Supply voltage	
Rated value (DC)	24 V
Rated value (AC)	230 V; 110 V
Current carrying capacity	
up to 60 °C, max.	10 A
Potential separation	
between backplane bus and supply voltage	Yes

4.10 BU type B0, dark-colored version, with AUX terminals, supply over P1, P2 busbar

Article number	6ES7193-6BP20-0BB0
Isolation	
Isolation tested with	3 250 V DC
Dimensions	
Width	20 mm
Height	117 mm
Depth	35 mm
Weights	
Weight, approx.	48 g

4.11 BU type B1, dark-colored version, without AUX terminals, supply over supply terminals

Short designation

Short designation: BU20-P12+A0+4B

4.11.1 Product overview

Delivery options (packing unit VPE)

6ES7193-6BP20-0BB1 (VPE: 1 unit)

6ES7193-6BP20-2BB1 (VPE: 10 units)

View

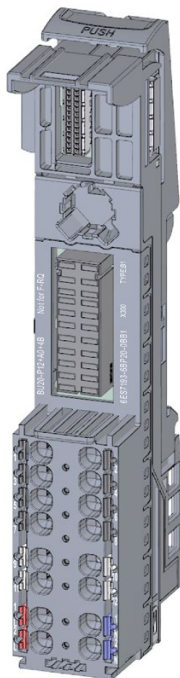

Figure 4-19 BU type B1, dark-colored version, without AUX terminals, supply over supply terminals

4.11 BU type B1, dark-colored version, without AUX terminals, supply over supply terminals

Properties

- BaseUnit suitable for all I/O modules of the BaseUnit type "B1". Can be recognized by the laser inscription on the front and/or the last two digits of the article number.
 - Current-carrying capacity per process terminal (terminal 1 to 12): Max. 5 A
- The BaseUnit conducts the potential group further. The self-assembling voltage buses P1 and P2, and the AUX busbar are connected to the left-hand neighboring module (BaseUnit).
- No access to the power and AUX busbars via terminals
- 12 terminals to the process (assignment with the I/O module)
- Connection system in the form of push-in terminals Connection cross-sections are available in the ET 200SP System Manual (<https://support.industry.siemens.com/cs/ww/de/view/58649293>).

4.11.2 Connecting up

Pin assignment

Pin assignment for BU type B1, dark-colored version, without AUX terminals, supply over supply terminals	
Terminal	Descriptions
1 to 12	Assignment is determined by the I/O module. You can find additional information in the I/O Module manual. (http://support.automation.siemens.com/WW/view/de/55679691/133300)
(AUX)	No access to the AUX busbar via terminals
1 L, 2 L, (P1) / 1 N, 2 N, (P2)	1 L, 2 L: Rated supply voltage up to 230 V AC with max. 10 A 1 N, 2 N: Neutral/Ground

Block diagram

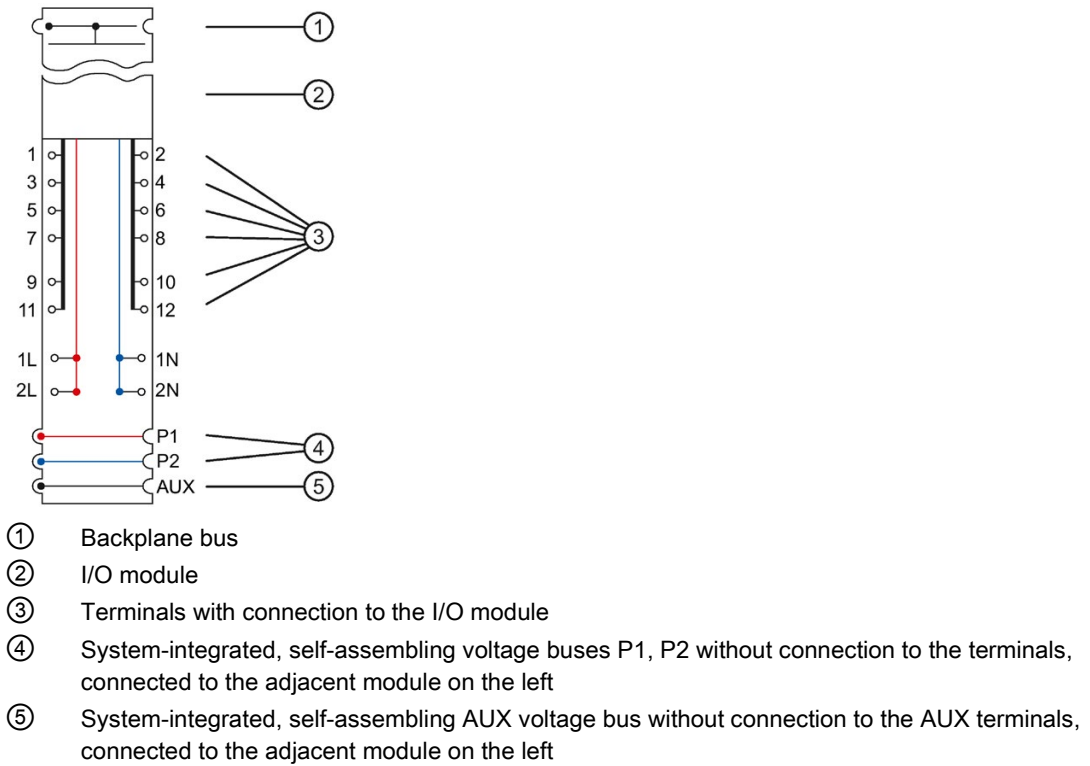

Figure 4-20 Block diagram of the BU type B1, dark-colored version, without AUX terminals, supply over supply terminals

4.11.3 Technical specifications

Technical specifications of the BU type B1, dark-colored version, without AUX terminals, supply over supply terminals

Article number	6ES7193-6BP20-0BB1
General information	
Product type designation	Type B1
Supply voltage	
Rated value (DC)	24 V
Rated value (AC)	230 V; 110 V
Current carrying capacity	
up to 60 °C, max.	10 A

4.11 BU type B1, dark-colored version, without AUX terminals, supply over supply terminals

Article number	6ES7193-6BP20-0BB1
Potential separation	
between backplane bus and supply voltage	Yes
between process terminals and supply voltage	Yes
between power bus and supply voltage	Yes
Isolation	
Isolation tested with	3 250 V DC
Dimensions	
Width	20 mm
Height	117 mm
Depth	35 mm
Weights	
Weight, approx.	48 g

4.12 BU type C0, light-colored version, with AUX terminals, supply over supply terminals

Short designation

Short designation: BU20-P6+A2+4D

4.12.1 Product overview

Delivery options (packing unit VPE)

6ES7193-6BP20-0DC0 (VPE: 1 unit)

View

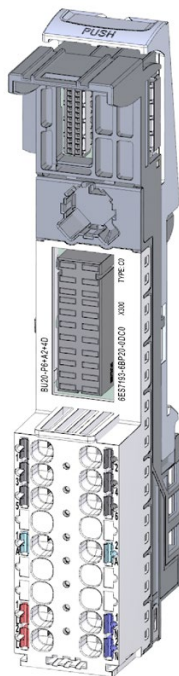

Figure 4-21 BU type C0, light-colored version, with AUX terminals, supply over supply terminals

Properties

- BaseUnit suitable for all I/O modules of BaseUnit type "C0/C1". Can be recognized by the laser inscription on the front and/or the last two digits of the article number.
 - Supply voltage (terminal 1 L, 2 / 1 N, 2 N): Max. 230 V AC/10 A
 - Current-carrying capacity per process terminal (terminal 1 to 4): Max. 5 A
 - Current carrying capacity per process terminal (terminal 5 and 6): Max. 10 A
- The BaseUnit opens up a new potential group by means of the inserted I/O module. The self-assembling voltage buses P1 and P2, and the AUX busbar are interrupted to the left-hand neighboring module (BaseUnit, interface module).
- Access to the AUX busbar via terminals
- 6 terminals to the process (assignment with the I/O module)
- Two AUX terminals for connecting a PE terminal or potential. The AUX busbar is not connected to the I/O module. Max. 24 V DC/10 A
- Connection system in the form of push-in terminals You can find more information in the ET 200SP System Manual (<https://support.industry.siemens.com/cs/ww/de/view/58649293>).

Maximum configuration per potential group

The number of I/O modules that can be used per potential group depends on the following factors:

1. Total power requirement of all I/O modules operated on this potential group
2. Total power requirement of all loads connected externally to this potential group

The total current calculated according to item 1. and item 2. must not exceed 10 A.

4.12.2 Connecting

Pin assignment

Pin assignment for BU type C0, light-colored version, with AUX terminals, supply over supply terminals	
Terminal	Descriptions
1 to 6	Assignment is determined by the I/O module. You can find additional information in the I/O Module manual. (http://support.automation.siemens.com/WW/view/en/55679691/133300)
1 A, 2 A, AUX	Protective conductor connection or voltage bus, freely usable up to 230 V AC/DC with max. 10 A. If you connect a voltage, it must belong to the same potential group as the rated supply voltage.
1 L, 2 L, (P1) / 1 N, 2 N, (P2)	1 L, 2 L: Rated supply voltage up to 230 V AC with max. 10 A 1 N, 2 N: Neutral/Ground

Block diagram

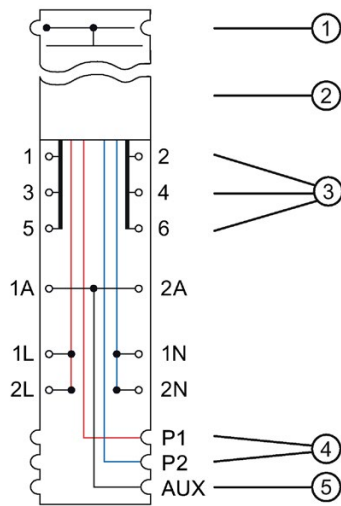

- ① Backplane bus
- ② I/O module
- ③ Terminals with connection to the I/O module
- ④ System-integrated, self-assembling voltage buses P1, P2 with connection to the supply terminals (through the inserted I/O module) Interrupted to the adjacent module on the left (forms a new potential group)
- ⑤ System-integrated, self-assembling AUX voltage bus with connection to the AUX terminals, interrupted to the adjacent module on the left (forms a new potential group)

Figure 4-22 Block diagram of the BU type C0, light-colored version, with AUX terminals, supply over supply terminals

4.12.3 Technical specifications

Technical specifications of the BU type C0, light-colored version, with AUX terminals, supply over supply terminals

Article number	6ES7193-6BP20-0DC0
General information	
Product type designation	Type C0
Supply voltage	
Rated value (DC)	24 V; 30 V
Rated value (AC)	230 V; 110 V
external protection for power supply lines	Yes; 10 A miniature circuit breaker with type B or C tripping characteristic for the respective rated supply voltage
Current carrying capacity	
up to 60 °C, max.	10 A
Potential separation	
between backplane bus and supply voltage	Yes
between process terminals and supply voltage	Yes
Isolation	
Isolation tested with	3 250 V DC
Dimensions	
Width	20 mm
Height	117 mm
Depth	35 mm
Weights	
Weight, approx.	47 g

4.13 BU type C1, dark-colored version, with AUX terminals, supply over P1, P2 busbar

Short designation

Short designation: BU20-P6+A2+4B

4.13.1 Product overview

Delivery options (packing unit VPE)

6ES7193-6BP20-0BC1 (VPE: 1 unit)

View

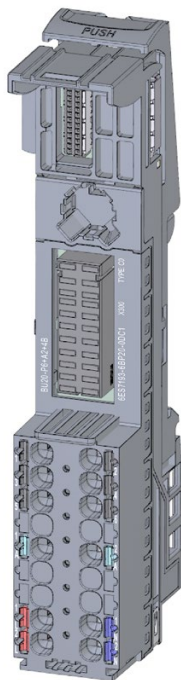

Figure 4-23 BU type C1, dark-colored version, with AUX terminals, supply over P1, P2 busbar

4.13 BU type C1, dark-colored version, with AUX terminals, supply over P1, P2 busbar

Properties

- BaseUnit suitable for all I/O modules of BaseUnit type "C0/C1". Can be recognized by the laser inscription on the front and/or the last two digits of the article number.
 - Current-carrying capacity per process terminal (terminal 1 to 4): Max. 5 A
 - Current carrying capacity per process terminal (terminal 5 and 6): Max. 10 A
- The BaseUnit further conducts the potential group. The self-assembling voltage buses P1 and P2, and the AUX bus are connected to the left-hand neighboring module (BaseUnit).
- Access to the AUX busbar via terminals
- 6 terminals to the process (assignment with the I/O module)
- Two AUX terminals for connecting a PE terminal or potential. The AUX busbar is not connected to the I/O module. Max. 24 V DC/10 A
- Connection system in the form of push-in terminals Connection cross-sections are available in the ET 200SP System Manual (<https://support.industry.siemens.com/cs/ww/de/view/58649293>).

4.13.2 Connecting

Pin assignment

Pin assignment for BU type C1, dark-colored version, with AUX terminals, supply over P1, P2 busbar	
Terminal	Descriptions
1 to 6	Assignment is determined by the I/O module. You can find additional information in the I/O Module (http://support.automation.siemens.com/WW/view/en/55679691/133300) manual.
1 A, 2 A, AUX	Protective conductor connection or voltage bus, freely usable up to 230 V AC/DC with max 10 A. If you connect a voltage, it must belong to the same potential group as the rated supply voltage.
1 L, 2 L, (P1) / 1 N, 2 N, (P2)	1 L, 2 L: Rated supply voltage up to 230 V AC with max. 10 A 1 N, 2 N: Neutral/Ground

Block diagram

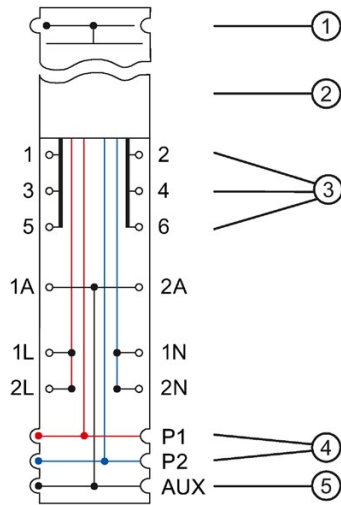

- ① Backplane bus
- ② Power module
- ③ Terminals with connection to the I/O module
- ④ System-integrated, self-assembling voltage buses P1, P2 with connection to the supply terminals (through the inserted I/O module) Connected to the adjacent module on the left
- ⑤ System-integrated, self-assembling AUX voltage bus with connection to the AUX terminals, connected to the adjacent module on the left

Figure 4-24 Block diagram of the BU type C1, dark-colored version, with AUX terminals, supply over P1, P2 busbar

4.13.3 Technical specifications

Technical specifications of the BU type C1, dark-colored version, with AUX terminals, supply over P1, P2 busbar

Article number	6ES7193-6BP20-0BC1
General information	
Product type designation	Type C1
Supply voltage	
Rated value (DC)	24 V; 30 V
Rated value (AC)	230 V; 110 V
Current carrying capacity	
up to 60 °C, max.	10 A

4.13 BU type C1, dark-colored version, with AUX terminals, supply over P1, P2 busbar

Article number	6ES7193-6BP20-0BC1
Potential separation	
between backplane bus and supply voltage	Yes
between process terminals and supply voltage	Yes
Isolation	
Isolation tested with	3 250 V DC
Dimensions	
Width	20 mm
Height	117 mm
Depth	35 mm
Weights	
Weight, approx.	47 g

4.14 BU type D0, dark-colored version, without AUX terminals, supply over supply terminals

Short designation

Short designation: BU20-P12+A0+0B

4.14.1 Product overview

Delivery options (packing unit VPE)

6ES7193-6BP00-0BD0 (VPE: 1 unit)

View

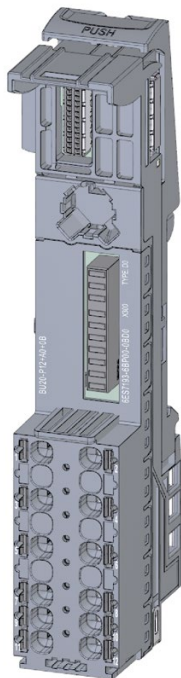

Figure 4-25 BU type D0, dark-colored version, without AUX terminals, supply over supply terminals

4.14 BU type D0, dark-colored version, without AUX terminals, supply over supply terminals

Properties

- BaseUnit suitable for all I/O modules of the BaseUnit type "D0". Can be recognized by the laser inscription on the front and/or the last two digits of the article number.
 - Current-carrying capacity per process terminal (terminal 1 to 12): Max. 5 A
- The BaseUnit further conducts the potential group. The self-assembling voltage buses P1 and P2, and the AUX busbar are connected to the left-hand neighboring module (BaseUnit).
- No access to the power and AUX busbars via terminals
- 12 terminals to the process (assignment with the I/O module)
- Connection system in the form of push-in terminals Connection cross-sections are available in the ET 200SP System Manual (<https://support.industry.siemens.com/cs/ww/de/view/58649293>).

Note

The shield connection (shield support and shield terminal) is not intended for BaseUnit BU20-P12+A0+0B and must not be installed.

4.14.2 Connecting**Pin assignment**

Pin assignment for BU type D0, dark-colored version, without AUX terminals, supply over supply terminals	
Terminal	Descriptions
1 to 12	Assignment is determined by the I/O module. You can find additional information in the I/O Module (http://support.automation.siemens.com/WW/view/en/55679691/133300) manual.
(AUX)	No access to the AUX busbar via terminals

Block diagram

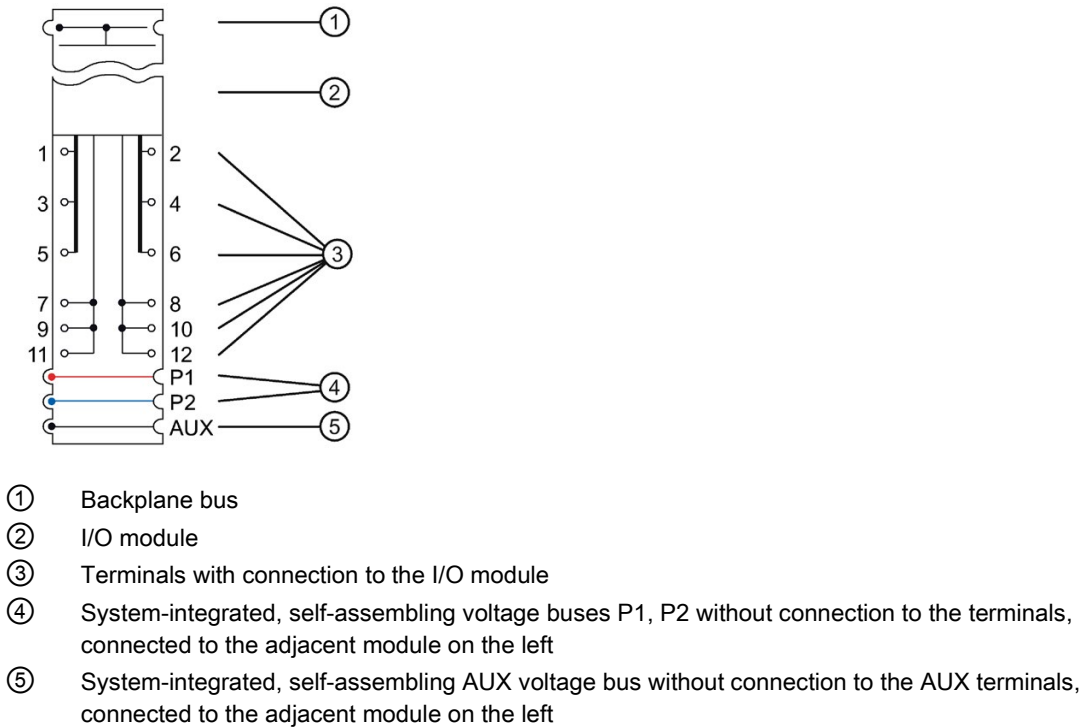

Figure 4-26 Block diagram of the BU type D0, dark-colored version, without AUX terminals, supply over supply terminals

4.14.3 Technical specifications

Technical specifications of the BU type D0, dark-colored version, without AUX terminals, supply over supply terminals

Article number	6ES7193-6BP00-0BD0
General information	
Product type designation	Type D0
Supply voltage	
Rated value (AC)	400 V; 230 V AC (L1, N)
Current carrying capacity	
up to 60 °C, max.	5 A
Isolation	
Isolation tested with	3 250 V DC
Dimensions	
Width	20 mm
Height	117 mm
Depth	35 mm
Weights	
Weight, approx.	47 g

4.15 BU type F0, dark-colored version, with AUX terminals, supply over supply terminals

Short designation

Short designation: BU20-P8+A4+0B

4.15.1 Product overview

When you use the AUX terminals as a PE busbar:

NOTICE
When AUX is used as PE, AUX must be identified as green-yellow (e.g., gn/ye color-coded labels). These identifications must be removed if the terminals are no longer used as PE.

Delivery options (packing unit VPE)

6ES7193-6BP20-0BF0 (VPE: 1 unit)

View

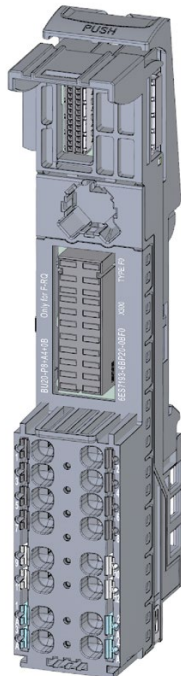

Figure 4-27 BU type F0, dark-colored version, with AUX terminals, supply over supply terminals

Properties

- BaseUnit suitable for all I/O modules of the BaseUnit type "F0". Can be recognized by the laser inscription on the front and/or the last two digits of the article number.
 - Current carrying capacity per process terminal (terminals 1 to 4 and 9 to 12): Max. 5 A
- The BaseUnit loops the potential group through with the self-assembling voltage buses P1, P2 and the AUX bus of the left-hand neighboring module (BaseUnit).
- Access to the AUX busbar via terminals 1 A to 4 A max. 24 V DC/10 A
- 8 terminals to the process (occupied by the I/O module)
- Connection system in the form of push-in terminals Connection cross-sections are available in the ET 200SP System Manual (<https://support.industry.siemens.com/cs/ww/de/view/58649293>).

4.15.2 Connecting up

Pin assignment

Pin assignment for BU type F0, dark-colored version, with AUX terminals, supply over supply terminals		
Terminals of a potential group	Fail-safe module Overvoltage category 3	Non-fail-safe module Overvoltage category 2
1 to 4	Up to 230 V AC/DC (AC only one phase) Assignment is determined by the I/O module. You can find additional information in the I/O Module (http://support.automation.siemens.com/WW/view/en/55679691/133300) manual.	
9 to 12	Safe extra low voltage SELV/PELV Assignment is determined by the I/O module. You can find additional information in the I/O Module (http://support.automation.siemens.com/WW/view/en/55679691/133300) manual.	
P1, P2, AUX (1 A to 4 A)	SELV/PELV (max. 10 A)	SELV/PELV or up to 230 V AC/DC (AC only one phase) (max. 10 A)

Use the AUX terminals only with an identical voltage or PE associated with the supply voltage.

4.15 BU type F0, dark-colored version, with AUX terminals, supply over supply terminals

Block diagram

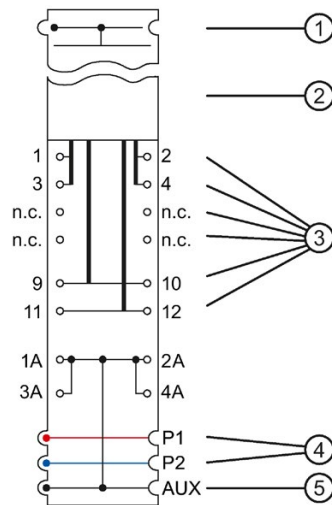

- ① Backplane bus
- ② I/O module
- ③ Terminals with connection to the I/O module
- ④ System-integrated, self-assembling voltage buses P1, P2 without connection to the terminals, connected to the adjacent module on the left
- ⑤ System-integrated, self-assembling AUX voltage bus with connection to the AUX terminals, connected to the adjacent module on the left

Figure 4-28 Block diagram of the BU type F0, dark-colored version, with AUX terminals, supply over supply terminals

4.15.3 Technical specifications

Technical specifications of the BU type F0, dark-colored version, with AUX terminals, supply over supply terminals

Article number	6ES7193-6BP20-0BF0
General information	
Product type designation	Type F0
Supply voltage	
Rated value (DC)	See manual
Rated value (AC)	See manual
Current carrying capacity	
up to 60 °C, max.	10 A

4.15 BU type F0, dark-colored version, with AUX terminals, supply over supply terminals

Article number	6ES7193-6BP20-0BF0
Potential separation	
between backplane bus and supply voltage	Yes
between process terminals and supply voltage	Yes
between power bus and supply voltage	Yes
Isolation	
Isolation tested with	3 250 V DC/1 min (type test), 2 545 V DC/2 s (routine test)
Dimensions	
Width	20 mm
Height	117 mm
Depth	35 mm
Weights	
Weight, approx.	48 g

4.16 BU type U0, light-colored version without AUX terminals

Short designation

Short designation: BU20-P16+A0+2D

4.16.1 Product overview

Delivery options (packing unit VPE)

6ES7193-6BP00-0DU0 (VPE: 1 unit)

6ES7193-6BP00-2DU0 (VPE: 10 units)

View

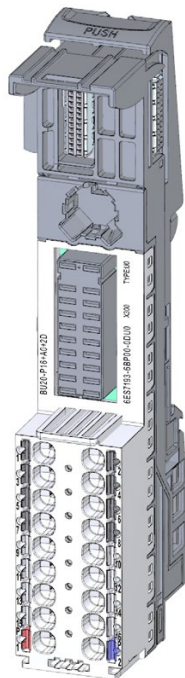

Figure 4-29 BU type U0, light-colored version without AUX terminals

4.16 BU type U0, light-colored version without AUX terminals

Properties

- BaseUnit suitable for all I/O modules of the BaseUnit type "U0". Can be recognized by the laser inscription on the front and/or the last two digits of the article number.
 - Current-carrying capacity per process terminal (terminal 1 to 16): Max. 10 A
- The BaseUnit opens up a new potential group. The self-assembling voltage buses P1, P2 and the AUX busbar are disconnected from the adjacent module on the left (BaseUnit, interface module, CPU).
- No access to the AUX busbar via terminals
- 16 terminals to the process (assignment through the I/O module)
- Connection system in the form of push-in terminals Connection cross-sections are available in the ET 200SP System Manual (<https://support.industry.siemens.com/cs/ww/de/view/58649293>).

Maximum configuration per potential group

The number of I/O modules that can be used per potential group depends on the following factors:

1. Total power requirement of all I/O modules operated on this potential group
2. Total power requirement of all loads connected externally to this potential group

The total current calculated according to item 1. and item 2. must not exceed 10 A.

Note

A potential group opened with light-colored BaseUnit of type U0 must contain no dark-colored BaseUnit of type A0 or A1.

4.16.2 Connection

Pin assignment

Pin assignment for BU type U0, light-colored version, without AUX terminals	
Terminal	Descriptions
1 to 16	Assignment is determined by the I/O module. You can find additional information in the I/O Module (http://support.automation.siemens.com/WW/view/de/55679691/133300) manual.
(AUX)	No access to the AUX busbar via terminals
P1 / P2	P1: Rated supply voltage up to 230 V AC with max. 10 A P2: Neutral/Ground

Block diagram

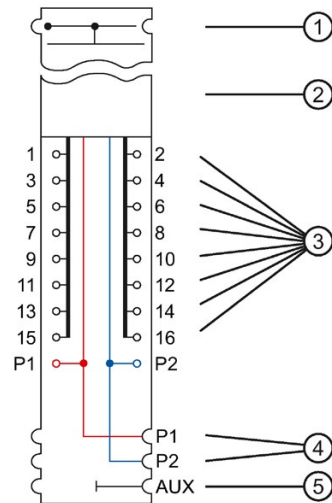

- ① Backplane bus
- ② I/O module
- ③ Terminals with connection to the I/O module
- ④ System-integrated, self-assembling voltage buses P1, P2 with connection to the supply terminals, interrupted to the adjacent module on the left (forms a new potential group)
- ⑤ System-integrated, self-assembling AUX voltage bus without connection to the AUX terminals, interrupted to the adjacent module on the left (forms a new potential group)

Figure 4-30 Block diagram of the BU type U0, light-colored version, without AUX terminals

4.16.3 Technical specifications

Technical specifications of the BU type U0, light-colored version without AUX terminals

Article number	6ES7193-6BP00-0DU0
General information	
Product type designation	BU type U0, BU20-P16+A0+2D, PU 1
Supply voltage	
Rated value (DC)	120 V
• For P1 and P2 bus	120 V
• For AUX bus	120 V
Rated value (AC)	240 V; 400 V (L1 - L2 - L3); 240 V (L1, N)
• For P1 and P2 bus	240 V
• For AUX bus	240 V
• for process terminals	240 V
external protection for power supply lines	Yes

Article number	6ES7193-6BP00-0DU0
Mains filter	
<ul style="list-style-type: none"> integrated 	Yes
Current carrying capacity	
up to 60 °C, max.	10 A
For P1 and P2 bus, max.	10 A
For AUX bus, max.	10 A
For process terminals, max.	10 A
Hardware configuration	
Automatic encoding	Yes
Formation of potential groups	
<ul style="list-style-type: none"> New potential group 	No
<ul style="list-style-type: none"> Potential group continued from the left 	Yes
Potential separation	
between backplane bus and supply voltage	Yes
between the potential groups	Yes
Isolation	
Isolation tested with	3 100 V DC for 2 s
Connection method	
Terminals	
<ul style="list-style-type: none"> Terminal type 	Push-in terminal
<ul style="list-style-type: none"> Conductor cross-section, min. 	0.14 mm ² ; 0.2 mm ² without wire end ferrule
<ul style="list-style-type: none"> Conductor cross-section, max. 	2.5 mm ² ; 1.5 mm ² with wire end ferrule
<ul style="list-style-type: none"> Number of process terminals to I/O module 	16
<ul style="list-style-type: none"> Number of terminals to AUX bus 	0
<ul style="list-style-type: none"> Number of add-on terminals 	0
<ul style="list-style-type: none"> Number of terminals with connection to P1 and P2 bus 	2
Dimensions	
Width	20 mm
Height	117 mm
Depth	35 mm
Weights	
Weight, approx.	50 g

4.17 BU type U0, dark-colored version, without AUX terminals

Short designation

Short designation: BU20-P16+A0+2B

4.17.1 Product overview

Delivery options (packing unit VPE)

6ES7193-6BP00-0BU0 (VPE: 1 unit)

6ES7193-6BP00-2BU0 (VPE: 10 units)

View

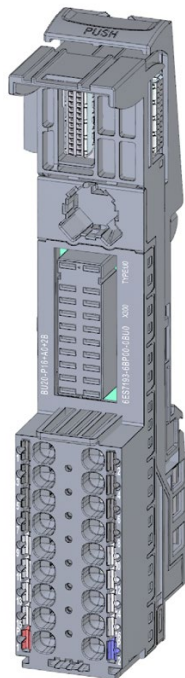

Figure 4-31 BU type U0, dark-colored version, without AUX terminals

4.17 BU type U0, dark-colored version, without AUX terminals

Properties

- BaseUnit suitable for all I/O modules of the BaseUnit type "U0". Can be recognized by the laser inscription on the front and/or the last two digits of the article number.
 - Current-carrying capacity per process terminal (terminal 1 to 16): Max. 10 A
- The BaseUnit conducts the potential group further. The self-assembling voltage buses P1 and P2, and the AUX busbar are connected to the left-hand neighboring module (BaseUnit).
- No access to the AUX busbar via terminals
- 16 terminals to the process (assignment through the I/O module)
- Connection system in the form of push-in terminals Connection cross-sections are available in the ET 200SP System Manual (<https://support.industry.siemens.com/cs/ww/de/view/58649293>).

4.17.2 Connection

Pin assignment

Pin assignment for BU type U0, dark-colored version, without AUX terminals	
Terminal	Descriptions
1 to 16	Assignment is determined by the I/O module. You can find additional information in the I/O Module (http://support.automation.siemens.com/WW/view/de/55679691/133300) manual.
(AUX)	No access to the AUX busbar via terminals
P1 / P2	P1: Rated supply voltage up to 230 V AC with max. 10 A P2: Neutral/Ground

Block diagram

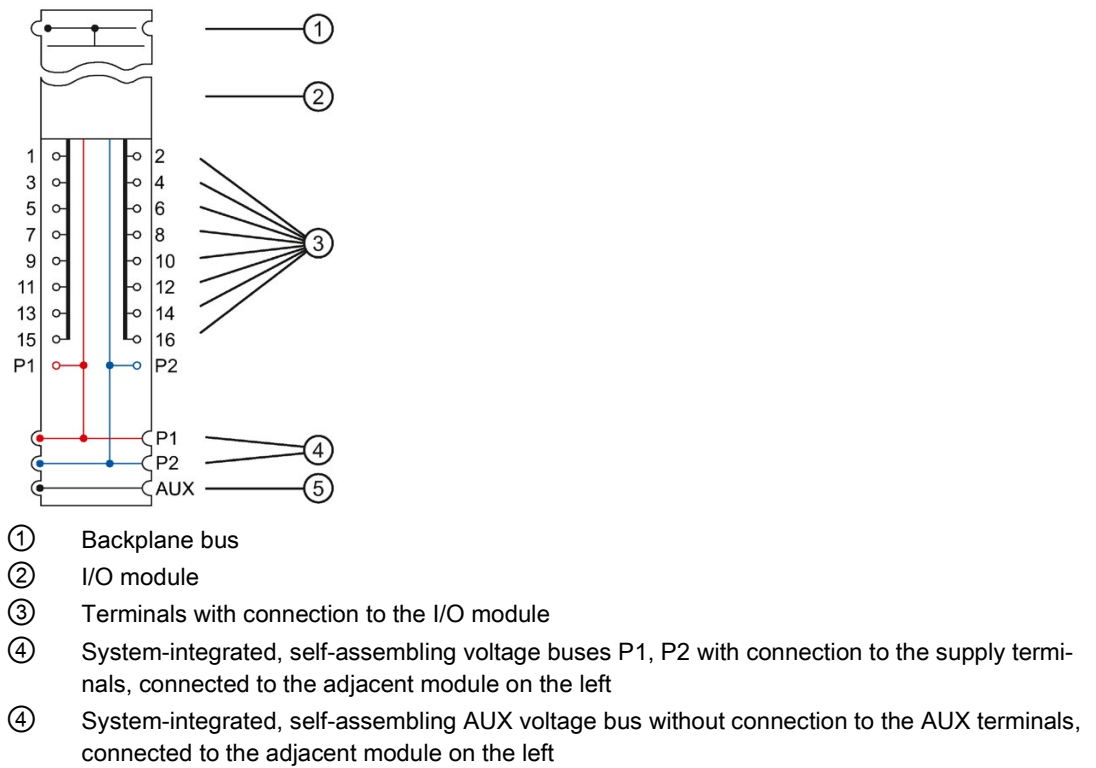

Figure 4-32 Block diagram of the BU type U0, dark-colored version, without AUX terminals

4.17.3 Technical specifications

Technical specifications of the BU type U0, dark-colored version, without AUX terminals

Article number	6ES7193-6BP00-0BU0
General information	
Product type designation	BU type U0, BU20-P16+A0+2B, PU 1
Supply voltage	
Rated value (DC)	120 V
• For P1 and P2 bus	120 V
• For AUX bus	120 V
Rated value (AC)	240 V; 400 V (L1 - L2 - L3); 240 V (L1, N)
• For P1 and P2 bus	240 V
• For AUX bus	240 V
• for process terminals	240 V
external protection for power supply lines	Yes

Article number	6ES7193-6BP00-0BU0
Mains filter	
<ul style="list-style-type: none"> integrated 	No
Current carrying capacity	
up to 60 °C, max.	10 A
For P1 and P2 bus, max.	10 A
For AUX bus, max.	10 A
For process terminals, max.	10 A
Hardware configuration	
Automatic encoding	Yes
Formation of potential groups	
<ul style="list-style-type: none"> New potential group 	No
<ul style="list-style-type: none"> Potential group continued from the left 	Yes
Potential separation	
between backplane bus and supply voltage	Yes
Isolation	
Isolation tested with	3 100 V DC for 2 s
Connection method	
Terminals	
<ul style="list-style-type: none"> Terminal type 	Push-in terminal
<ul style="list-style-type: none"> Conductor cross-section, min. 	0.14 mm ² ; 0.2 mm ² without wire end ferrule
<ul style="list-style-type: none"> Conductor cross-section, max. 	2.5 mm ² ; 1.5 mm ² with wire end ferrule
<ul style="list-style-type: none"> Number of process terminals to I/O module 	16
<ul style="list-style-type: none"> Number of terminals to AUX bus 	0
<ul style="list-style-type: none"> Number of add-on terminals 	0
<ul style="list-style-type: none"> Number of terminals with connection to P1 and P2 bus 	2
Dimensions	
Width	20 mm
Height	117 mm
Depth	35 mm
Weights	
Weight, approx.	50 g

BaseUnits for motor starters

5.1 Introduction

Properties of the infeed bus

- The infeed bus is set up by connecting the BaseUnits, and wiring takes place automatically
- The infeed bus distributes the energy to the SIMATIC ET 200SP motor starter within one load group
- The max. current carrying capacity is up to 32 A (3-phase)
 - With infeed (for one load group) and motor connection
 - Infeed bus: 3-pole + PE
 - The voltage range for power infeed is 48 ... 500 V AC

You must observe the deratings depending on the configuration.

Properties of the self-assembling voltage bus (power bus)

- Maximum current: 7 A
- Rated voltage: 24 V DC

You must observe the deratings depending on the configuration.

AUX1 bus

The AUX1 bus is not supported in the BaseUnits of the SIMATIC ET 200SP motor starters.

You can find assembly rules of the BaseUnits for the SIMATIC ET 200SP motor starter in the System Manual SIMATIC ET 200SP motor starters.

5.2 BU30-MS1 - BaseUnit with 24 V DC and 500 V AC infeed

5.2.1 Product overview

Article number

3RK1908-0AP00-0AP0

View



Figure 5-1 BaseUnit with 24 V DC and 500 V AC infeed

Properties

- BaseUnit suitable for all fail-safe and non-fail-safe SIMATIC ET 200SP High Feature motor starters
- The BaseUnit opens a new potential group (24 V DC). The power buses P1 and P2 are interrupted to the left-hand neighboring module (BaseUnit, interface module/CPU).
- The BaseUnit opens a new potential group (500 V DC). The infeed bus L1 (L), L2 (N), L3, PE is interrupted to the left-hand BaseUnit of the ET 200SP motor starter.
- Connection method using push-in terminals
- The touch protection cover for the infeed bus (3RK1908-1DA00-2BP0) is included in the scope of delivery.
- The fail-safe input F-DI of the fail-safe motor starter is connected to the power bus.

Maximum configuration per voltage group (24 V DC)

The number of I/O modules that can be used per potential group depends on the following factors:

1. Total power requirement of all I/O modules operated on this potential group
2. Total power requirement of all loads connected externally to this potential group

The total current calculated according to item 1. and item 2. must not exceed 7 A.

Maximum configuration of the infeed bus (500 V AC)

The number of motor starters that can be used per infeed group depends on the following factors:

1. Total current requirement of all motor starters operated on this infeed group.
2. Ambient temperature and installation type in which the motor starters are operated.
You can find further information in the derating table in the Manual SIMATIC ET 200SP motor starters (<https://support.industry.siemens.com/cs/ww/en/view/109479973>).

5.2.2 Connection

Pin assignment

Pin assignment for BaseUnit with 24 V DC and 500 V AC infeed	
Terminal	Descriptions
L1(L), L2(N), L3, PE	Power supply Assignment is determined by the motor starter. You can find more information in the ET 200SP Motor Starter (https://support.industry.siemens.com/cs/ww/en/view/109479973) manual.
T1, T2, T3, PE	Motor feeder
24 V DC, M	24 V DC: Supply voltage 24 V DC with max. 7 A M: Ground

Block diagram

The figure below shows the block diagram of the BaseUnit with 24 V DC and 500 V AC infeed.

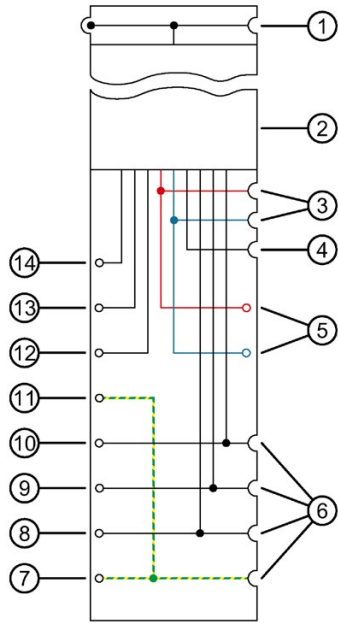

- ① Backplane bus
- ② Motor starter module
- ③ Interrupted busbars 24 V DC, M
- ④ Interrupted AUX bus
- ⑤ Terminals for 24 V DC and ground M
- ⑥ Interrupted busbars for the infeed system L1(L), L2(N), L3, PE
- ⑦ Infeed terminal for protective ground PE
- ⑧ Infeed terminal L3
- ⑨ Infeed terminal L2(N)
- ⑩ Infeed terminal L1(L)
- ⑪ Terminal for protective ground PE
- ⑫ Terminal T3
- ⑬ Terminal T2
- ⑭ Terminal T1

Figure 5-2 Block diagram BaseUnit with 24 V DC and 500 V AC infeed

5.2.3 Technical specifications

Technical specifications of the BaseUnit with 24 V DC and 500 V AC infeed

3RK1908-0AP00-0AP0	
Product type designation	BU30-MS1
Galvanic isolation	
Galvanic isolation between backplane bus and supply voltage	Yes
Insulation tested with	2500 V AC
Rated operating voltage	24 V DC
Max. operating current	7 A (observe derating)
Rated insulation voltage in accordance with IEC 60947-1	500 V
Impulse withstand voltage/rated value U_{imp} according to IEC 60947-1	6 kV
Operating voltage range	48 ... 500 V AC
Max. current-carrying capacity	32 A (observe derating)
Isolating function between the infeed terminals L1(L), L2 (N), L3 and motor feeder terminals T1, T2, T3 for motor starters in parking position, or removed motor starters: impulse withstand voltage/rated value U_{imp} according to IEC 60947-1	6 kV
Wiring	
Push-in	Required tools for releasing: Standard screwdriver size 1 (SZF1 - 0.6x3.5)
Dimensions	
Width	30 mm
Height	215 mm
Weights	
Weight, approx.	164 g

5.3 BU30-MS2 - BaseUnit with 500 V AC infeed

5.3.1 Product overview

Article number

3RK1908-0AP00-0CP0

View



Figure 5-3 BaseUnit with 500 V AC infeed

Properties

- BaseUnit suitable for all fail-safe and non-fail-safe SIMATIC ET 200SP High Feature motor starters
- The BaseUnit takes over the potential group (P1, P2) from the adjacent module on the left.
- The BaseUnit opens a new supply group 500 V AC. The potential group (24 V DC) is further continued
- Connection method using push-in terminals
- The touch protection cover for the infeed bus is included in the scope of delivery.
- The fail-safe input F-DI of the fail-safe motor starter is connected to the power bus.

Maximum configuration of the infeed bus (500 V AC)

The number of motor starters that can be used per infeed group depends on the following factors:

1. Total current requirement of all motor starters operated on this infeed group.
2. Ambient temperature and installation type in which the motor starters are operated.
You can find further information in the derating table in the Manual SIMATIC ET 200SP motor starters.

5.3.2 Connection

Pin assignment

Pin assignment for BaseUnit with 500 V AC infeed	
Terminal	Descriptions
L1(L), L2(N), L3, PE	Power supply Assignment is determined by the motor starter. See Manual ET 200SP motor starters (https://support.industry.siemens.com/cs/ww/en/view/109479973).
T1, T2, T3, PE	Motor feeder

Block diagram

The figure below shows the block diagram of the BaseUnit with 500 V AC infeed.

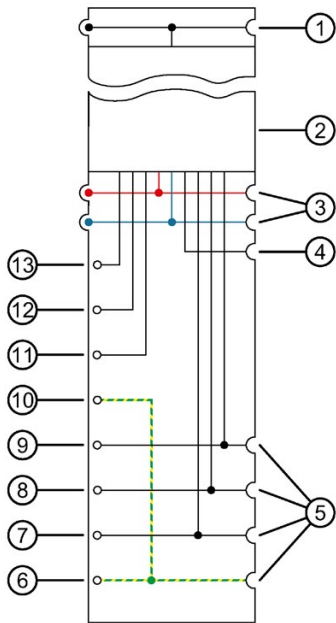

- ① Backplane bus
- ② Motor starter module
- ③ Connected power buses 24 V DC, M
- ④ Interrupted AUX bus
- ⑤ Interrupted busbars for the infeed system L1(L), L2(N), L3, PE
- ⑥ Infeed terminal for protective ground PE
- ⑦ Infeed terminal L3
- ⑧ Infeed terminal L2(N)
- ⑨ Infeed terminal L1(L)
- ⑩ Terminal for protective ground PE
- ⑪ Terminal T3
- ⑫ Terminal T2
- ⑬ Terminal T1

Figure 5-4 Block diagram BaseUnit with 500 V AC infeed

5.3.3 Technical specifications

Technical specifications of the BaseUnit with 500 V AC infeed

3RK1908-0AP00-0CP0	
Product type designation	BU30-MS2
Galvanic isolation	
Galvanic isolation between backplane bus and supply voltage	Yes
Insulation tested with	2500 V AC
Rated operating voltage	24 V DC
Max. operating current	7 A (observe derating)
Rated insulation voltage in accordance with IEC 60947-1	500 V
Impulse withstand voltage/rated value U_{imp} according to IEC 60947-1	6 kV
Operating voltage range	48 ... 500 V AC
Max. current-carrying capacity	32 A (observe derating)
Isolating function between the infeed terminals L1(L), L2 (N), L3 and motor feeder terminals T1, T2, T3 for motor starters in parking position, or removed motor starters: impulse withstand voltage/rated value U_{imp} according to IEC 60947-1	6 kV
Wiring	
Push-in	Required tools for releasing: Standard screwdriver size 1 (SZF1 - 0.6x3.5)
Dimensions	
Width	30 mm
Height	215 mm
Weight, approx.	160 g

5.4 BU30-MS3 - BaseUnit with 24 V DC infeed

5.4.1 Product overview

Article number

3RK1908-0AP00-0BP0

View



Figure 5-5 BaseUnit with 24 V DC infeed

Properties

- BaseUnit suitable for all fail-safe and non-fail-safe SIMATIC ET 200SP High Feature motor starters
- The BaseUnit opens a new potential group (24 V DC). The power buses P1 and P2 are interrupted to the left-hand neighboring module (BaseUnit, interface module/CPU).
- This BaseUnit handles the infeed bus (500 V AC) of the left-hand BaseUnit and loops this through.
- Connection method using push-in terminals
- The touch protection cover for the infeed bus is not included in the scope of delivery.
- The fail-safe input F-DI of the fail-safe motor starter is connected to the power bus.

Maximum configuration per voltage group (24 V DC)

The number of I/O modules that can be used per potential group depends on the following factors:

1. Total power requirement of all I/O modules operated on this potential group
2. Total power requirement of all loads connected externally to this potential group

The total current calculated according to item 1. and item 2. must not exceed 7 A.

5.4.2 Connection

Pin assignment

Pin assignment for BaseUnit with 24 V DC infeed	
Terminal	Descriptions
T1, T2, T3, PE	Motor feeder
24 V DC, M	24 V DC: Rated supply voltage 24 V DC with max. 7 A M: Ground

Block diagram

The figure below shows the three-phase connection with 24 V infeed and mains infeed.

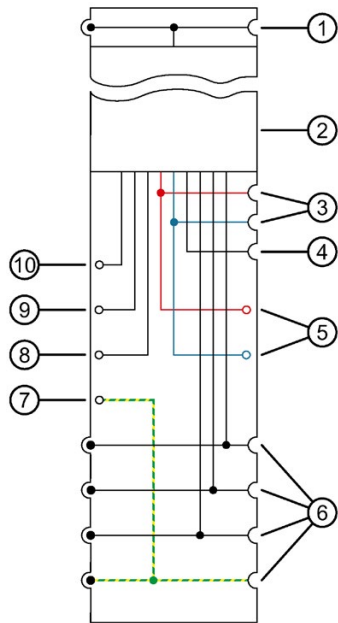

- ① Backplane bus
- ② Motor starter module
- ③ Interrupted busbars 24 V DC, M
- ④ Interrupted AUX bus
- ⑤ Terminal for 24 V DC and ground M
- ⑥ Connected busbars for the infeed system L1(L), L2(N), L3, PE
- ⑦ Terminal for protective ground PE
- ⑧ Terminal T3
- ⑨ Terminal T2
- ⑩ Terminal T1

Figure 5-6 Block diagram BaseUnit with 24 V DC infeed

5.4.3 Technical specifications

Technical specifications of the BaseUnit with 24 V DC infeed

3RK1908-0AP00-0BP0	
Product type designation	BU30-MS3
Galvanic isolation	
Galvanic isolation between backplane bus and supply voltage	Yes
Insulation tested with	2500 V AC
Rated operating voltage	24 V DC
Max. operating current	7 A (observe derating)
Rated insulation voltage in accordance with IEC 60947-1	500 V
Impulse withstand voltage/rated value U_{imp} according to IEC 60947-1	6 kV
Operating voltage range	48 ... 500 V AC
Max. current-carrying capacity	32 A (observe derating)
Isolating function between the infeed terminals L1(L), L2 (N), L3 and motor feeder terminals T1, T2, T3 for motor starters in parking position, or removed motor starters: impulse withstand voltage/rated value U_{imp} according to IEC 60947-1	6 kV
Wiring	
Push-in	Required tools for releasing: Standard screwdriver size 1 (SZF1 - 0.6x3.5)
Dimensions	
Width	30 mm
Height	215 mm
Weight, approx.	152 g

5.5 BU30-MS4 - BaseUnit without infeed

5.5.1 Product overview

Article number

3RK1908-0AP00-0DP0

View



Figure 5-7 BaseUnit without infeed

Properties

- BaseUnit suitable for all fail-safe and non-fail-safe SIMATIC ET 200SP High Feature motor starters
- No new potential groups are opened with this BaseUnit.
- The potential group (24 V DC) is looped through.
- The infeed group (500 V AC) is looped through.
- Connection method using push-in terminals
- The touch protection cover for the infeed bus is not included in the scope of delivery.
- The fail-safe input F-DI of the fail-safe motor starter is connected to the power bus.

5.5.2 Connection

Pin assignment

Pin assignment for BaseUnit without infeed	
Terminal	Descriptions
T1, T2, T3, PE	Motor feeder

Block diagram

The figure below shows the block diagram of the BaseUnit without infeed.

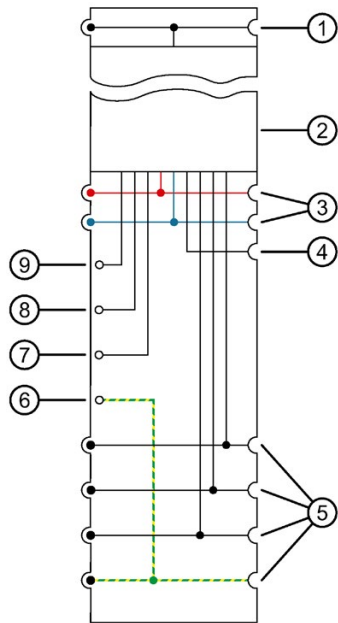

- ① Backplane bus
- ② Motor starter module
- ③ Connected busbars 24 V DC, M
- ④ Interrupted AUX bus
- ⑤ Connected busbars for the infeed system L1(L), L2(N), L3, PE
- ⑥ Terminal for protective ground PE
- ⑦ Terminal T3
- ⑧ Terminal T2
- ⑨ Terminal T1

Figure 5-8 Block diagram BaseUnit without infeed

5.5.3 Technical specifications

Technical specifications of BaseUnit without infeed

3RK1908-0AP00-0DP0	
Product type designation	BU30-MS4
Galvanic isolation	
Galvanic isolation between backplane bus and supply voltage	Yes
Insulation tested with	2500 V AC
Rated operating voltage	24 V DC
Max. operating current	7 A (observe derating)
Rated insulation voltage in accordance with IEC 60947-1	500 V
Impulse withstand voltage/rated value U_{imp} according to IEC 60947-1	6 kV
Operating voltage range	48 ... 500 V AC
Max. current-carrying capacity	32 A (observe derating)
Isolating function between the infeed terminals L1(L), L2 (N), L3 and motor feeder terminals T1, T2, T3 for motor starters in parking position, or removed motor starters: impulse withstand voltage/rated value U_{imp} according to IEC 60947-1	6 kV
Wiring	
Push-in	Required tools for releasing: Standard screwdriver size 1 (SZF1 - 0.6x3.5)
Dimensions	
Width	30 mm
Height	215 mm
Weight, approx.	150 g

5.6 BU30-MS5 BaseUnit with 500 V AC infeed and F-DI

5.6.1 Product overview

Article number

3RK1908-0AP00-0EP0

View



Figure 5-9 BaseUnit with 500 V AC and F-DI

Properties

- BaseUnit suitable for all fail-safe SIMATIC ET 200SP High Feature motor starters
- The BaseUnit takes over the potential group (P1, P2) from the adjacent module on the left.
- The BaseUnit opens a new supply group 500 V AC. The potential group (24 V DC) is further continued
- The BaseUnit has an F-DI input terminal for fail-safe control signals of the motor starter. This signal is not forwarded to neighboring motor starters.
- Connection method using push-in terminals
- The touch protection cover for the infeed bus is included in the scope of delivery.

Maximum configuration of the supply bus

The number of I/O modules that can be used per potential group depends on the following factors:

1. Total power requirement of all I/O modules operated on this potential group
2. Total power requirement of all loads connected externally to this potential group

The total current calculated according to item 1. and item 2. must not exceed 7 A.

Properties of the F-DI input

The fail-safe digital input "F-DI" has the following properties:

- Use of interconnection type 1oo1 possible
- Sink input
- Input delay 10 ms
- Status display of the input F-DI at the motor starter module (green LED)

5.6.2 Connection

Pin assignment

Pin assignment for BaseUnit with 500 V AC infeed and F-DI	
Terminal	Descriptions
T1, T2, T3, PE	Motor feeder
F-DI, M	F-DI: Connection of fail-safe signal M: Reference potential of fail-safe signal
L1(L), L2(N), L3, PE	Power supply Assignment is determined by the motor starter. You can find more information in the ET 200SP Motor Starter (https://support.industry.siemens.com/cs/ww/en/view/109479973) manual.

Block diagram

The figure below shows the two-phase connection with 500 V AC infeed and F-DI:

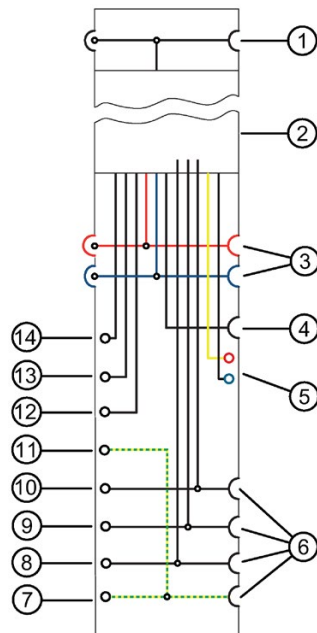

- ① Backplane bus
- ② Motor starter module
- ③ Connected busbars 24 V DC, M
- ④ Interrupted AUX bus
- ⑤ Safety input F-DI (P24/M)
- ⑥ Interrupted busbars for the infeed system L1(L), L2(N), L3, PE
- ⑦ Infeed terminal for protective ground PE
- ⑧ Infeed terminal L3
- ⑨ Infeed terminal L2(N)
- ⑩ Infeed terminal L1(L)
- ⑪ Terminal for protective ground PE
- ⑫ Terminal T3
- ⑬ Terminal T2
- ⑭ Terminal T1

Figure 5-10 BaseUnit block diagram with 500 V AC infeed and fail-safe input

5.6.3 Technical specifications

Technical specifications of the BaseUnit with 500 V AC infeed and F-DI

	3RK1908-0AP00-0EPO
Product type designation	BU30-MS5
Galvanic isolation	
Galvanic isolation between backplane bus and supply voltage	Yes
Insulation tested with	2500 V AC
Rated operating voltage	24 V DC
Max. operating current	7 A (observe derating)
Galvanic isolation between fail-safe digital input and supply voltage	Yes
Rated insulation voltage in accordance with IEC 60947-1	500 V
Impulse withstand voltage/rated value U_{imp} according to IEC 60947-1	6 kV
Operating voltage range	48 ... 500 V AC
Max. current-carrying capacity	32 A (observe derating)
Isolating function between the infeed terminals L1(L), L2 (N), L3 and motor feeder terminals T1, T2, T3 for motor starters in parking position, or removed motor starters: impulse withstand voltage/rated value U_{imp} according to IEC 60947-1	6 kV
Wiring	
Push-in	Required tools for releasing: Standard screwdriver size 1 (SZF1 - 0.6x3.5)
Dimensions	
Width	30 mm
Height	215 mm
Weight, approx.	152 g

5.7 BU30-MS6 BaseUnit without infeed and with F-DI

5.7.1 Product overview

Article number

3RK1908-0AP00-0FP0

View



Figure 5-11 BaseUnit without 500 V AC infeed, with F-DI

Properties

- BaseUnit suitable for all fail-safe SIMATIC ET 200SP High Feature motor starters
- The BaseUnit takes over the potential group (P1, P2) from the adjacent module on the left.
- This BaseUnit handles the potential group/infeed bus (500 V AC) of the left-hand BaseUnit and loops this through.
- The BaseUnit has an F-DI input terminal for fail-safe control signals of the motor starter. This signal is not forwarded to neighboring motor starters.
- Connection method using push-in terminals
- The touch protection cover for the infeed bus is not included in the scope of delivery.

Properties of the F-DI input

The fail-safe digital input "F-DI" has the following properties:

- Use of interconnection type 1oo1 possible
- Sink input
- Input delay 10 ms
- Status display of the input F-DI at the motor starter module (green LED)

5.7.2 Connection

Pin assignment

Pin assignment for BaseUnit with 24 V DC infeed	
Terminal	Descriptions
T1, T2, T3, PE	Motor feeder
F-DI, M	F-DI: Connection of fail-safe signal M: Reference potential of fail-safe signal

Block diagram

The following figure shows the block diagram for the BaseUnit without infeed, but with fail-safe input:

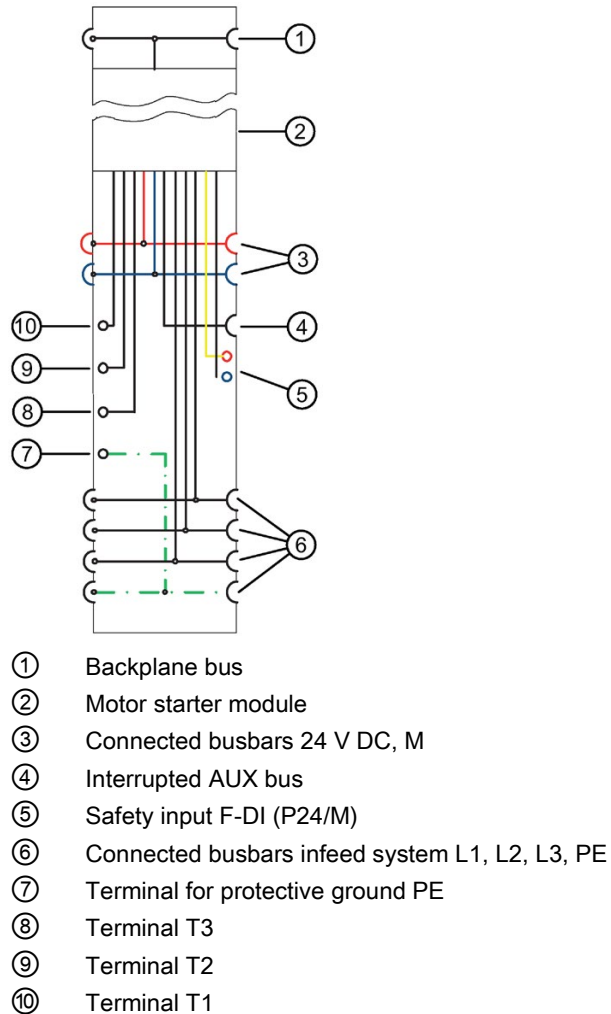

Figure 5-12 Block diagram BaseUnit without infeed, with fail-safe input

5.7.3 Technical specifications

Technical specifications of BaseUnit without infeed, with F-DI

	3RK1908-0AP00-0FP0
Product type designation	BU30-MS6
Galvanic isolation	
Galvanic isolation between backplane bus and supply voltage	Yes
Insulation tested with	2500 V AC
Rated operating voltage	24 V DC
Max. operating current	7 A (observe derating)
Rated insulation voltage in accordance with IEC 60947-1	500 V
Galvanic isolation between fail-safe digital input and supply voltage	Yes
Impulse withstand voltage/rated value U_{imp} according to IEC 60947-1	6 kV
Operating voltage range	48 ... 500 V AC
Max. current-carrying capacity	32 A (observe derating)
Isolating function between the infeed terminals L1(L), L2 (N), L3 and motor feeder terminals T1, T2, T3 for motor starters in parking position, or removed motor starters: impulse withstand voltage/rated value U_{imp} according to IEC 60947-1	6 kV
Wiring	
Push-in	Required tools for releasing: Standard screwdriver size 1 (SZF1 - 0.6x3.5)
Dimensions	
Width	30 mm
Height	215 mm
Weight, approx.	152 g

Potential distributor modules

6.1 Introduction

Properties of potential distributor modules

A potential distributor module (PotDis module) consists of a potential distributor BaseUnit (PotDis-BU) and a potential distributor terminal block (PotDis-TB) installed on top of it. A system-integrated potential distribution is possible with the various PotDis-BUs and PotDis-TBs.

You can place potential distributor modules at any location with the ET 200SP distributed I/O system. In doing so, you must observe the same design rules that apply to the design of a potential group from the BaseUnits for I/O modules. The following information is particularly important:

- The potential groups opened with a light-colored PotDis-BU must contain no I/O modules. You can integrate any dark-colored PotDis-BUs into I/O module potential groups provided these are based on SELV/PELV supply.
- If you do not need the additional terminals of the PotDis-TB in a potential distributor module, replace the PotDis-TB with a BU-Cover.
- You may only connect one potential group within a combination of PotDis-BU and PotDis-TB.
- Only SELV/PELV potentials are permitted on PotDis-BUs. Separate different SELV/PELV potential groups using light-colored PotDis-BUs.
- With potential distributor modules you may only connect to the PotDis-TB versions BR-W and n.c.-G potential, which exceed the voltage level of SELV/PELV.
- PotDis terminals are not directly configurable as PotDis via GSD/GSDML. When configuring with GSD, always use an empty module; with GSDML, integrate a free space.

Potential distributor modules are configurable with STEP 7/STEP 7 TIA Portal. Individual versions are listed in the following table:

Engineering with	version/HSP
STEP 7 TIA Portal	
<ul style="list-style-type: none"> • Configurable as of version • Configurable as of version • Configurable as of version • Configurable as of version 	HSP0241 up to V13 SP1 Update 8 HSP0241 up to V14 HSP0241 up to V14 SP1 Update 5 HSP0241 up to V15 Update 1
STEP 7	
<ul style="list-style-type: none"> • Configurable as of version 	HSP0293 up to V5.5 SP4

You can find additional information on the use of the potential distributor modules in the ET 200SP Distributed I/O System

(<http://support.automation.siemens.com/WW/view/en/58649293>) system manual.

6.2 PotDis-BU type P1, light-colored version

6.2.1 Short designation

Short designation

Light-colored version with 16 terminals to P1 + 2 supply terminals P1/P2.

Short designation: PotDis-BU-P1/D-R.

D stands for a new potential group, which means P1, P2, AUX separated to the left,
R stands for red spring release.

6.2.2 Product overview

Delivery options (packing unit VPE)

6ES7193-6UP00-0DP1 (VPE: 1 unit)

View

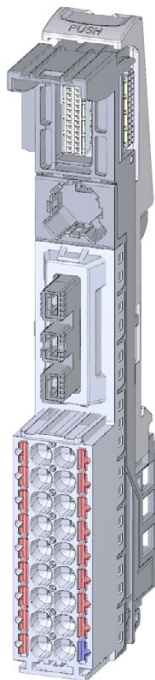

Figure 6-1 PotDis-BU type P1, light-colored version

Properties

- BaseUnit suitable for all PotDis terminal blocks of the type "P1/P2/N0/P0". Can be recognized by the laser inscription on the front and/or the last two digits of the article number.
 - Supply voltage (terminal P1, P2) up to DC 48 V/10 A
 - Current carrying capacity per terminal: Max. 10 A
- BaseUnit opens up a new PotDis potential group. The self-assembling voltage buses P1, P2 and the AUX busbar are disconnected from the adjacent module on the left (BaseUnit, CPU, interface module).

NOTICE
<p>Opening a potential group for I/O modules is not permitted with the BaseUnit PotDis-BU-P1/D-R.</p> <p>The BaseUnit PotDis-BU-P1/D-R opens a new potential group only for the potential distributor modules. Opening a potential group for I/O modules is not permitted with the BaseUnit PotDis-BU-P1/D-R.</p>

- 18 terminals
 - 17 red terminals (P1)
 - 1 blue terminal (P2)
- 36 terminals (with PotDis-TB)
- Connection system in the form of push-in terminals

6.2.3 Connecting

Pin assignment

Pin assignment for BaseUnit PotDis-BU type P1, light-colored version	
Terminal	Explanation
P1	Rated supply voltage up to 48 V DC with max. 10 A (17 red terminals)
P2	Ground (1 terminal)

Block diagram

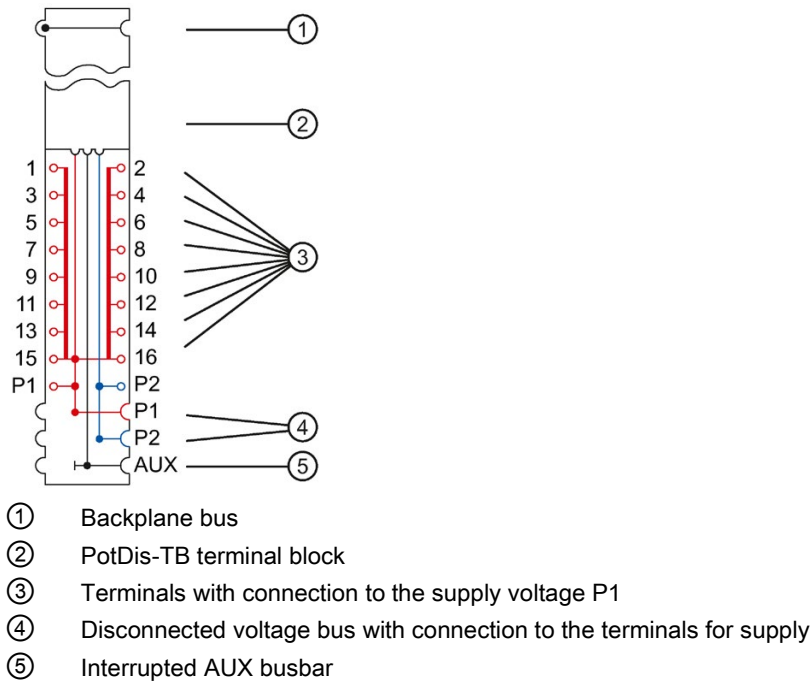

Figure 6-2 Block diagram of the PotDis-BU type P1, light-colored version

6.2.4 Technical specifications

Technical specifications of the BaseUnit PotDis-BU type P1, light-colored version

Article number	6ES7193-6UP00-0DP1
General information	
Product type designation	PotDis BU type P1, light version, PU 1
Supply voltage	
Rated value (DC)	
• For P1 and P2 bus	48 V; max.
• for process terminals	48 V; max.
external protection for power supply lines	Yes; 10 A miniature circuit breaker with type B or C tripping characteristic for the respective rated supply voltage
Current carrying capacity	
For P1 and P2 bus, max.	10 A
For process terminals, max.	10 A
Hardware configuration	
Formation of potential groups	
• New potential group	Yes
• Potential group continued from the left	No

Article number	6ES7193-6UP00-0DP1
Potential separation	
between backplane bus and supply voltage	Yes
Isolation	
Isolation tested with	3 250 V DC
Ambient conditions	
Ambient temperature during operation	
• horizontal installation, min.	0 °C; No condensation
• horizontal installation, max.	60 °C
• vertical installation, min.	0 °C; No condensation
• vertical installation, max.	50 °C
• Vertical installation, min.	0 °C; No condensation
• Vertical installation, max.	50 °C
• Horizontal installation, min.	0 °C; No condensation
• Horizontal installation, max.	50 °C
Altitude during operation relating to sea level	
• Ambient air temperature-barometric pressure-altitude	On request: Ambient temperatures lower than 0 °C (without condensation) and/or installation altitudes greater than 2 000 m
Accessories	
Color coding labels	
• for process terminals	CC62
Connection method	
Terminals	
• Terminal type	Push-in terminal
• Conductor cross-section, min.	0.14 mm ²
• Conductor cross-section, max.	2.5 mm ²
• Number of terminals with connection to P1 and P2 bus	17 terminals to P1, 1 terminal to P2
Dimensions	
Width	15 mm
Height	117 mm
Depth	35 mm
Weights	
Weight, approx.	40 g

6.3 PotDis-BU type P1, dark-colored version

Short designation

Dark-colored version with 16 terminals to P1 + 2 supply terminals P1/P2.

Short designation: PotDis-BU-P1/B-R.

B stands for bridged potential group, which means P1, P2, AUX bridged to the left,
R stands for red spring release.

6.3.1 Product overview

Delivery options (packing unit VPE)

6ES7193-6UP00-0BP1 (VPE: 1 unit)

View

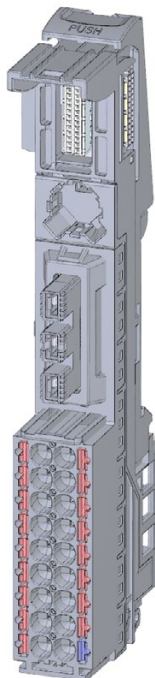

Figure 6-3 PotDis-BU type P1, dark-colored version

Properties

- BaseUnit suitable for all PotDis terminal blocks of the type "P1/P2/N0/P0". Can be recognized by the laser inscription on the front and/or the last two digits of the article number.
 - Current carrying capacity per terminal: Max. 10 A
- BaseUnit further conducts the potential group. The self-assembling voltage buses P1, P2 and the AUX busbar are connected to the adjacent module on the left (BaseUnit).
- 18 terminals
 - 17 red terminals (P1)
 - 1 blue terminal (P2)
- 36 terminals (with PotDis-TB)
- Connection system in the form of push-in terminals

6.3.2 Connecting

Pin assignment

Pin assignment for BaseUnit PotDis-BU type P1, dark-colored version	
Terminal	Explanation
P1	Rated supply voltage up to 48 V DC with max. 10 A (17 red terminals)
P2	Ground (1 terminal)

Block diagram

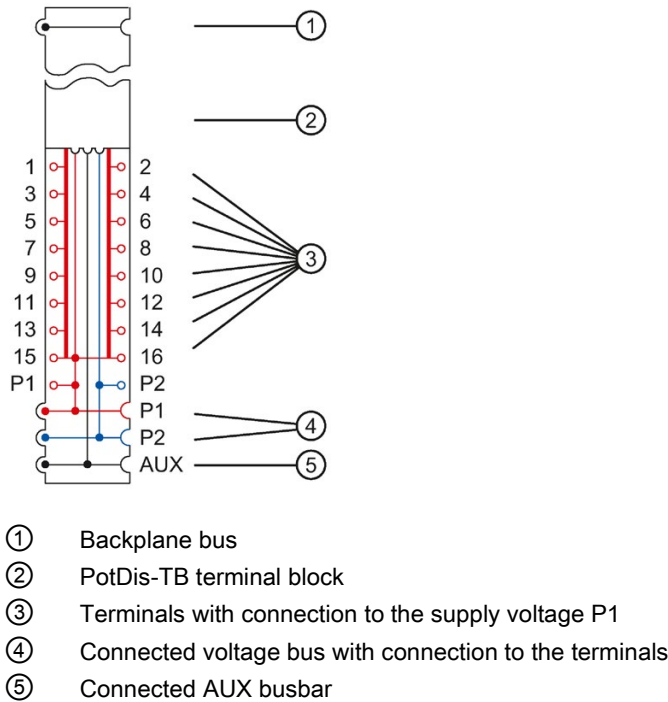

Figure 6-4 Block diagram of the PotDis-BU type P1, dark-colored version

6.3.3 Technical specifications

Technical specifications of the BaseUnit PotDis-BU type P1, dark-colored version

Article number	6ES7193-6UP00-0BP1
General information	
Product type designation	PotDis BU type P1, dark version, PU 1
Supply voltage	
Rated value (DC)	
• For P1 and P2 bus	48 V; max.
• for process terminals	48 V; max.
external protection for power supply lines	Yes; 10 A miniature circuit breaker with type B or C tripping characteristic for the respective rated supply voltage
Current carrying capacity	
For P1 and P2 bus, max.	10 A
For process terminals, max.	10 A

Article number	6ES7193-6UP00-0BP1
Hardware configuration	
Formation of potential groups	
<ul style="list-style-type: none"> New potential group 	No
<ul style="list-style-type: none"> Potential group continued from the left 	Yes
Potential separation	
between backplane bus and supply voltage	Yes
Isolation	
Isolation tested with	3 250 V DC
Ambient conditions	
Ambient temperature during operation	
<ul style="list-style-type: none"> horizontal installation, min. 	0 °C; No condensation
<ul style="list-style-type: none"> horizontal installation, max. 	60 °C
<ul style="list-style-type: none"> vertical installation, min. 	0 °C; No condensation
<ul style="list-style-type: none"> vertical installation, max. 	50 °C
<ul style="list-style-type: none"> Vertical installation, min. 	0 °C; No condensation
<ul style="list-style-type: none"> Vertical installation, max. 	50 °C
<ul style="list-style-type: none"> Horizontal installation, min. 	0 °C; No condensation
<ul style="list-style-type: none"> Horizontal installation, max. 	50 °C
Altitude during operation relating to sea level	
<ul style="list-style-type: none"> Ambient air temperature-barometric pressure-altitude 	On request: Ambient temperatures lower than 0 °C (without condensation) and/or installation altitudes greater than 2 000 m
Accessories	
Color coding labels	
<ul style="list-style-type: none"> for process terminals 	CC62
Connection method	
Terminals	
<ul style="list-style-type: none"> Terminal type 	Push-in terminal
<ul style="list-style-type: none"> Conductor cross-section, min. 	0.14 mm ²
<ul style="list-style-type: none"> Conductor cross-section, max. 	2.5 mm ²
<ul style="list-style-type: none"> Number of terminals with connection to P1 and P2 bus 	17 terminals to P1, 1 terminal to P2
Dimensions	
Width	15 mm
Height	117 mm
Depth	35 mm
Weights	
Weight, approx.	40 g

6.4 PotDis-BU type P2, light-colored version

6.4.1 Short designation

Short designation

Light-colored version with 16 terminals to P2 + 2 supply terminals P1/P2.

Short designation: PotDis-BU-P2/D-B.

D stands for a new potential group, which means P1, P2, AUX separated to the left,
B stands for blue spring release.

6.4.2 Product overview

Delivery options (packing unit VPE)

6ES7193-6UP00-0DP2 (VPE: 1 unit)

View

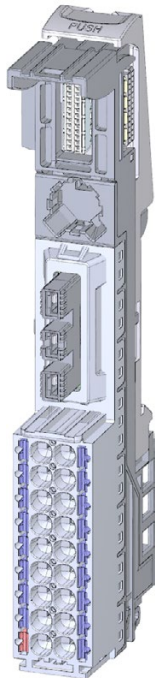

Figure 6-5 PotDis-BU type P2, light-colored version

Properties

- BaseUnit suitable for all PotDis terminal blocks of the type "P1/P2/N0/P0". Can be recognized by the laser inscription on the front and/or the last two digits of the article number.
 - Supply voltage (terminal P1, P2) up to DC 48 V/10 A
 - Current carrying capacity per terminal: Max. 10 A
- BaseUnit opens up a new PotDis potential group. The self-assembling voltage buses P1, P2 and the AUX busbar are disconnected from the adjacent module on the left (BaseUnit, CPU, interface module).

NOTICE

Opening a potential group for I/O modules is not permitted with the BaseUnit PotDis-BU-P2/D-B.

The BaseUnit PotDis-BU-P2/D-B opens a new potential group only for the potential distributor modules. Opening a potential group for I/O modules is not permitted with the BaseUnit PotDis-BU-P2/D-B.

- 18 terminals
 - 1 red terminal (P1)
 - 17 blue terminals (P2)
- 36 terminals (with PotDis-TB)
- Connection system in the form of push-in terminals

6.4.3 Connecting

Pin assignment

Pin assignment for PotDis-BU type P2, light-colored version	
Terminal	Explanation
P1	Rated supply voltage up to 48 V DC with max. 10 A (1 terminal)
P2	Ground (17 terminals)

Block diagram

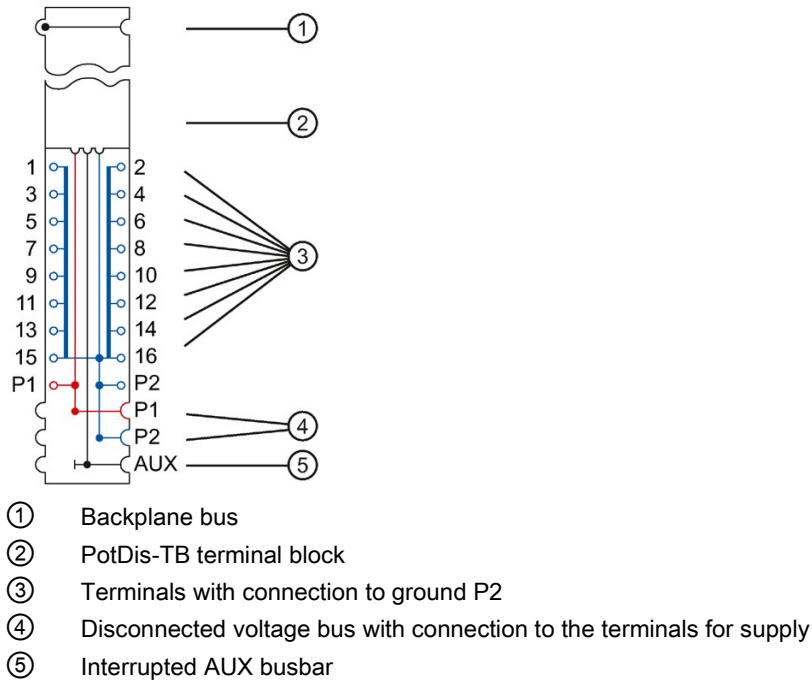

Figure 6-6 Block diagram of the PotDis-BU type P2, light-colored version

6.4.4 Technical specifications

Technical specifications of the BaseUnit PotDis-BU type P2, light-colored version

Article number	6ES7193-6UP00-0DP2
General information	
Product type designation	PotDis BU type P2, light version, PU 1
Supply voltage	
Rated value (DC)	
• For P1 and P2 bus	48 V; max.
• for process terminals	48 V; max.
external protection for power supply lines	Yes; 10 A miniature circuit breaker with type B or C tripping characteristic for the respective rated supply voltage
Current carrying capacity	
For P1 and P2 bus, max.	10 A
For process terminals, max.	10 A

Article number	6ES7193-6UP00-0DP2
Hardware configuration	
Formation of potential groups	
<ul style="list-style-type: none"> • New potential group 	No
<ul style="list-style-type: none"> • Potential group continued from the left 	Yes
Potential separation	
between backplane bus and supply voltage	Yes
Isolation	
Isolation tested with	3 250 V DC
Ambient conditions	
Ambient temperature during operation	
<ul style="list-style-type: none"> • horizontal installation, min. 	0 °C; No condensation
<ul style="list-style-type: none"> • horizontal installation, max. 	60 °C
<ul style="list-style-type: none"> • vertical installation, min. 	0 °C; No condensation
<ul style="list-style-type: none"> • vertical installation, max. 	50 °C
<ul style="list-style-type: none"> • Vertical installation, min. 	0 °C; No condensation
<ul style="list-style-type: none"> • Vertical installation, max. 	50 °C
<ul style="list-style-type: none"> • Horizontal installation, min. 	0 °C; No condensation
<ul style="list-style-type: none"> • Horizontal installation, max. 	50 °C
Altitude during operation relating to sea level	
<ul style="list-style-type: none"> • Ambient air temperature-barometric pressure-altitude 	On request: Ambient temperatures lower than 0 °C (without condensation) and/or installation altitudes greater than 2 000 m
Accessories	
Color coding labels	
<ul style="list-style-type: none"> • for process terminals 	CC63
Connection method	
Terminals	
<ul style="list-style-type: none"> • Terminal type 	Push-in terminal
<ul style="list-style-type: none"> • Conductor cross-section, min. 	0.14 mm ²
<ul style="list-style-type: none"> • Conductor cross-section, max. 	2.5 mm ²
<ul style="list-style-type: none"> • Number of terminals with connection to P1 and P2 bus 	18; 17 terminals to P2, 1 terminal to P1
Dimensions	
Width	15 mm
Height	117 mm
Depth	35 mm
Weights	
Weight, approx.	40 g

6.5 PotDis-BU type P2, dark-colored version

6.5.1 Short designation

Short designation

Dark-colored version with 16 terminals to P2 + 2 supply terminals P1/P2.

Short designation: PotDis-BU-P2/B-B.

B stands for bridged potential group, which means P1, P2, AUX bridged to the left,
B stands for blue spring release.

6.5.2 Product overview

Delivery options (packing unit VPE)

6ES7193-6UP00-0BP2 (VPE: 1 unit)

View

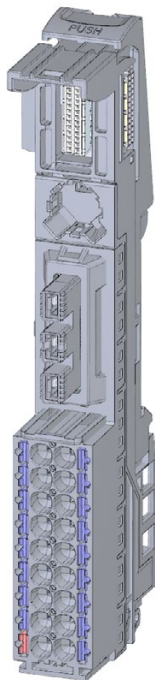

Figure 6-7 PotDis-BU type P2, dark-colored version

Properties

- BaseUnit suitable for all PotDis terminal blocks of the type "P1/P2/N0/P0". Can be recognized by the laser inscription on the front and/or the last two digits of the article number.
 - Current carrying capacity per terminal: Max. 10 A
- BaseUnit further conducts the potential group. The self-assembling voltage buses P1, P2 and the AUX busbar are connected to the adjacent module on the left (BaseUnit).
- 18 terminals
 - 1 red terminal (P1)
 - 17 blue terminals (P2)
- 36 terminals (with PotDis-TB)
- Connection system in the form of push-in terminals

6.5.3 Connecting

Pin assignment

Pin assignment for PotDis-BU type P2, dark-colored version	
Terminal	Explanation
P1	Rated supply voltage up to 48 V DC with max. 10 A (1 terminal)
P2	Ground (17 terminals)

Block diagram

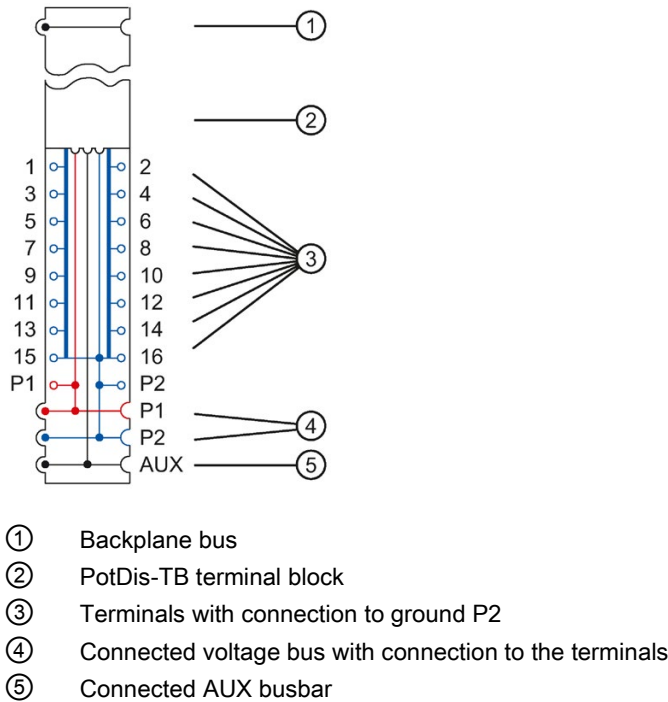

Figure 6-8 Block diagram of the PotDis-BU type P2, dark-colored version

6.5.4 Technical specifications

Technical specifications of the BaseUnit PotDis-BU type P2, dark-colored version

Article number	6ES7193-6UP00-0BP2
General information	
Product type designation	PotDis BU type P2, dark version, PU 1
Supply voltage	
Rated value (DC)	
• For P1 and P2 bus	48 V; max.
• for process terminals	48 V; max.
external protection for power supply lines	Yes; 10 A miniature circuit breaker with type B or C tripping characteristic for the respective rated supply voltage
Current carrying capacity	
For P1 and P2 bus, max.	10 A
For process terminals, max.	10 A

Article number	6ES7193-6UP00-0BP2
Hardware configuration	
Formation of potential groups	
<ul style="list-style-type: none"> • New potential group • Potential group continued from the left 	<p>No</p> <p>Yes</p>
Potential separation	
between backplane bus and supply voltage	Yes
Isolation	
Isolation tested with	3 250 V DC
Ambient conditions	
Ambient temperature during operation	
<ul style="list-style-type: none"> • horizontal installation, min. • horizontal installation, max. • vertical installation, min. • vertical installation, max. • Vertical installation, min. • Vertical installation, max. • Horizontal installation, min. • Horizontal installation, max. 	<p>0 °C; No condensation</p> <p>60 °C</p> <p>0 °C; No condensation</p> <p>50 °C</p> <p>0 °C; No condensation</p> <p>50 °C</p> <p>0 °C; No condensation</p> <p>50 °C</p>
Altitude during operation relating to sea level	
<ul style="list-style-type: none"> • Ambient air temperature-barometric pressure-altitude 	On request: Ambient temperatures lower than 0 °C (without condensation) and/or installation altitudes greater than 2 000 m
Accessories	
Color coding labels	
<ul style="list-style-type: none"> • for process terminals 	CC63
Connection method	
Terminals	
<ul style="list-style-type: none"> • Terminal type • Conductor cross-section, min. • Conductor cross-section, max. • Number of terminals with connection to P1 and P2 bus 	<p>Push-in terminal</p> <p>0.14 mm²</p> <p>2.5 mm²</p> <p>18; 17 terminals to P2, 1 terminal to P1</p>
Dimensions	
Width	15 mm
Height	117 mm
Depth	35 mm
Weights	
Weight, approx.	40 g

6.6 PotDis-TB

6.6.1 Product overview

Article number

- PotDis-TB-P1-R terminal block: 6ES7193-6TP00-0TP1
- PotDis-TB-P2-B terminal block: 6ES7193-6TP00-0TP2
- PotDis-TB-n.c.-G terminal block: 6ES7193-6TP00-0TN0
- PotDis-TB-BR-W terminal block: 6ES7193-6TP00-0TP0

View

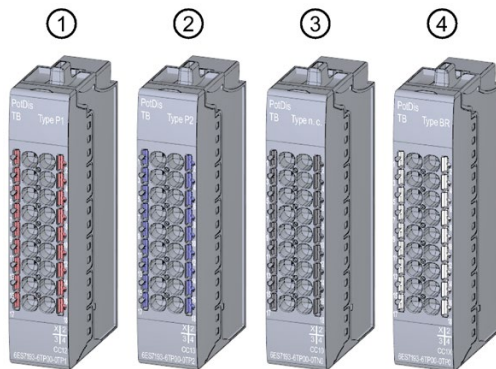

- ① PotDis-TB-P1-R
- ② PotDis-TB-P2-B
- ③ PotDis-TB-n.c.-G
- ④ PotDis-TB-BR-W

Figure 6-9 PotDis terminal blocks

Properties

- Terminal blocks matching all BaseUnits PotDis-BU
 - Current carrying capacity per terminal: Max. 10 A
- 18 terminals
 - PotDis-TB-P1-R terminal block: Red terminals with connection to the supply voltage P1 of the BaseUnit PotDis-BU
 - PotDis-TB-P2-B terminal block: Blue terminals with connection to ground P2 of the BaseUnit PotDis-BU
 - PotDis-TB-n.c.-G terminal block: Gray (internal not connected) terminals without connection to the BaseUnit PotDis-BU

NOTICE

Mixed connection of direct current or alternating current (DC/AC) is not permitted on the PotDis-TB-n.c.-G

Connect direct currents up to 48 V or alternating currents up to 230 V to the terminals of the PotDis-TB-n.c.-G. A mixed connection of both types of voltages (DC/AC) is not permitted at the terminals of the PotDis-TB-n.c.-G.
--

- PotDis-TB-BR-W terminal block: White (internal not connected) terminals without connection to the BaseUnit-BU

NOTICE

Only PotDis-TB-BR may be used for protective conductors.

Check all protective conductors.

Check the required conductor cross-section for the respective plant unit before commissioning of the plant (especially for motor starters).

- Connection system in the form of push-in terminals
- You can find the assignment of color-coded labels in the ET 200SP System Manual under Accessories.

NOTICE

Use of color-coded labels

Before commissioning the system, check that the color-coded labels attached correspond to the wired potential.
--

NOTICE

Voltages greater than SELV/PELV
--

Voltages greater than SELV/PELV are only permitted for the PO PotDis-TBs BR (bridged) and NC (not connected). This applies equally to protective conductors.
--

No voltages greater than SELV/PELV are present on the terminals of the PotDis module with connection to the P1/P2 rails.
--

6.6.2 Connecting

Pin assignment

Pin assignment for PotDis-TB terminal block		
Terminal block	Terminal	Explanation
PotDis-TB-P1-R	P1	Rated supply voltage up to 48 V DC with max. 10 A (18 red terminals)
PotDis-TB-P2-B	P2	Ground (18 blue terminals)
PotDis-TB-n.c.-G	n c. (not connected)	Terminals can be used freely up to 230 V AC with max. 10 A (18 gray terminals). If you connect voltage, it must belong to the same potential group.
PotDis-TB-BR-W	BR (bridged)	Terminals for protective conductor connection or voltage bus freely usable up to 230 V AC with max. 10 A (18 white terminals)

Block diagram

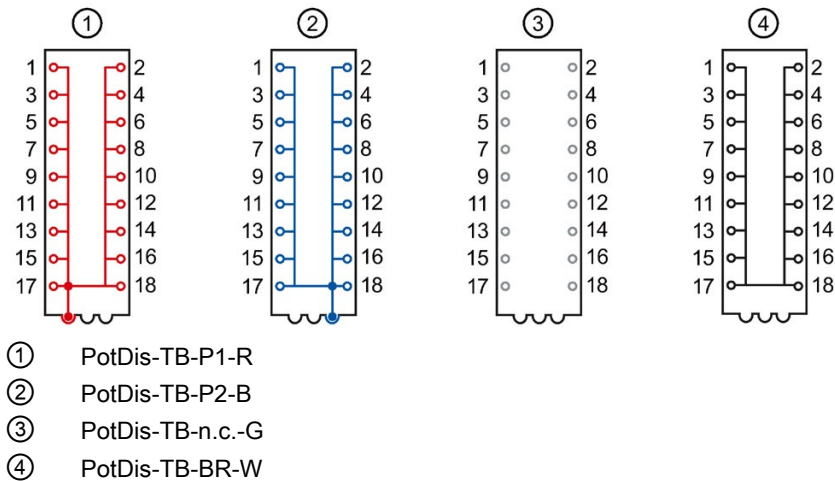

Figure 6-10 PotDis-TB block diagram

6.6.3 Technical specifications

Technical specifications of the PotDis-TB-P1_R terminal block

Article number	6ES7193-6TP00-0TP1
General information	
Product type designation	PotDis TB P1-R, PU 1
Supply voltage	
Rated value (DC)	
• For P1 and P2 bus	48 V; max.
• for process terminals	48 V; max.
Rated value (AC)	
• For P1 and P2 bus	240 V; max.
• for process terminals	240 V; max.
external protection for power supply lines	Yes; 10 A miniature circuit breaker with type B or C tripping characteristic for the respective rated supply voltage
Current carrying capacity	
up to 60 °C, max.	10 A
For P1 and P2 bus, max.	10 A
For AUX bus, max.	10 A
For process terminals, max.	10 A
Ambient conditions	
Ambient temperature during operation	
• horizontal installation, min.	0 °C; No condensation
• horizontal installation, max.	60 °C
• vertical installation, min.	0 °C; No condensation
• vertical installation, max.	50 °C
• Vertical installation, min.	0 °C; No condensation
• Vertical installation, max.	50 °C
• Horizontal installation, min.	0 °C; No condensation
• Horizontal installation, max.	50 °C
Altitude during operation relating to sea level	
• Ambient air temperature-barometric pressure-altitude	On request: Ambient temperatures lower than 0 °C (without condensation) and/or installation altitudes greater than 2 000 m

Article number	6ES7193-6TP00-0TP1
Accessories	
Color coding labels	
<ul style="list-style-type: none"> • for process terminals 	CC12
Connection method	
Terminals	
<ul style="list-style-type: none"> • Terminal type 	Push-in terminal
<ul style="list-style-type: none"> • Conductor cross-section, min. 	0.14 mm ² ; 0.2 mm ² without wire end ferrule
<ul style="list-style-type: none"> • Conductor cross-section, max. 	2.5 mm ² ; 1.5 mm ² with wire end ferrule
<ul style="list-style-type: none"> • Number of process terminals to I/O module 	16
<ul style="list-style-type: none"> • Number of terminals to AUX bus 	0
<ul style="list-style-type: none"> • Number of add-on terminals 	0
<ul style="list-style-type: none"> • Number of terminals with connection to P1 and P2 bus 	2
Dimensions	
Width	15 mm
Height	74 mm
Depth	34 mm
Weights	
Weight, approx.	24 g

Technical specifications of the PotDis-TB-P2-B terminal block

Article number	6ES7193-6TP00-0TP2
General information	
Product type designation	PotDis TB P2-B, PU 1
Supply voltage	
Rated value (DC)	
<ul style="list-style-type: none"> For P1 and P2 bus for process terminals 	48 V; max. 48 V; max.
Rated value (AC)	
<ul style="list-style-type: none"> For P1 and P2 bus for process terminals 	240 V; max. 240 V; max.
external protection for power supply lines	Yes; 10 A miniature circuit breaker with type B or C tripping characteristic for the respective rated supply voltage
Current carrying capacity	
up to 60 °C, max.	10 A
For P1 and P2 bus, max.	10 A
For AUX bus, max.	10 A
For process terminals, max.	10 A
Potential separation	
between process terminals and supply voltage	No
Ambient conditions	
Ambient temperature during operation	
<ul style="list-style-type: none"> horizontal installation, min. horizontal installation, max. vertical installation, min. vertical installation, max. Vertical installation, min. Vertical installation, max. Horizontal installation, min. Horizontal installation, max. 	0 °C; No condensation 60 °C 0 °C; No condensation 50 °C 0 °C; No condensation 50 °C 0 °C; No condensation 50 °C
Altitude during operation relating to sea level	
<ul style="list-style-type: none"> Ambient air temperature-barometric pressure-altitude 	On request: Ambient temperatures lower than 0 °C (without condensation) and/or installation altitudes greater than 2 000 m

Article number	6ES7193-6TP00-0TP2
Accessories	
Color coding labels	
<ul style="list-style-type: none"> for process terminals 	CC13
Connection method	
Terminals	
<ul style="list-style-type: none"> Terminal type 	Push-in terminal
<ul style="list-style-type: none"> Conductor cross-section, min. 	0.14 mm ² ; 0.2 mm ² without wire end ferrule
<ul style="list-style-type: none"> Conductor cross-section, max. 	2.5 mm ² ; 1.5 mm ² with wire end ferrule
<ul style="list-style-type: none"> Number of process terminals to I/O module 	16
<ul style="list-style-type: none"> Number of terminals to AUX bus 	0
<ul style="list-style-type: none"> Number of add-on terminals 	0
<ul style="list-style-type: none"> Number of terminals with connection to P1 and P2 bus 	2
Dimensions	
Width	15 mm
Height	74 mm
Depth	34 mm
Weights	
Weight, approx.	24 g

Technical specifications of the PotDis-TB-n.c.-G

Article number	6ES7193-6TP00-0TN0
General information	
Product type designation	PotDis TB n.c. G, PU 1
Supply voltage	
Rated value (DC)	48 V; max.
<ul style="list-style-type: none"> for process terminals 	
Rated value (AC)	240 V; max.
<ul style="list-style-type: none"> for process terminals 	
external protection for power supply lines	Yes; 10 A miniature circuit breaker with type B or C tripping characteristic for the respective rated supply voltage
Current carrying capacity	
up to 60 °C, max.	10 A
For P1 and P2 bus, max.	10 A
For AUX bus, max.	10 A
Potential separation	
between process terminals and supply voltage	Yes
Ambient conditions	
Ambient temperature during operation	
<ul style="list-style-type: none"> horizontal installation, min. 	0 °C; No condensation
<ul style="list-style-type: none"> horizontal installation, max. 	60 °C
<ul style="list-style-type: none"> vertical installation, min. 	0 °C; No condensation
<ul style="list-style-type: none"> vertical installation, max. 	50 °C
<ul style="list-style-type: none"> Vertical installation, min. 	0 °C; No condensation
<ul style="list-style-type: none"> Vertical installation, max. 	50 °C
<ul style="list-style-type: none"> Horizontal installation, min. 	0 °C; No condensation
<ul style="list-style-type: none"> Horizontal installation, max. 	50 °C
Altitude during operation relating to sea level	
<ul style="list-style-type: none"> Ambient air temperature-barometric pressure-altitude 	On request: Ambient temperatures lower than 0 °C (without condensation) and/or installation altitudes greater than 2 000 m

Article number	6ES7193-6TP00-0TN0
Accessories	
Color coding labels	
<ul style="list-style-type: none"> for process terminals 	CC10
Connection method	
Terminals	
<ul style="list-style-type: none"> Terminal type 	Push-in terminal
<ul style="list-style-type: none"> Conductor cross-section, min. 	0.14 mm ² ; 0.2 mm ² without wire end ferrule
<ul style="list-style-type: none"> Conductor cross-section, max. 	2.5 mm ² ; 1.5 mm ² with wire end ferrule
<ul style="list-style-type: none"> Number of process terminals to I/O module 	16
<ul style="list-style-type: none"> Number of terminals to AUX bus 	0
<ul style="list-style-type: none"> Number of add-on terminals 	0
<ul style="list-style-type: none"> Number of terminals with connection to P1 and P2 bus 	2
Dimensions	
Width	15 mm
Height	74 mm
Depth	34 mm
Weights	
Weight, approx.	24 g

Technical specifications of the PotDis-TB-BR-W terminal block

Article number	6ES7193-6TP00-0TP0
General information	
Product type designation	PotDis TB BR-W, PU 1
Supply voltage	
Rated value (DC)	48 V; max.
<ul style="list-style-type: none"> for process terminals 	
Rated value (AC)	240 V; max.
<ul style="list-style-type: none"> for process terminals 	
external protection for power supply lines	Yes; 10 A miniature circuit breaker with type B or C tripping characteristic for the respective rated supply voltage
Current carrying capacity	
up to 60 °C, max.	10 A
For P1 and P2 bus, max.	10 A
For AUX bus, max.	10 A
For process terminals, max.	10 A
Potential separation	
between process terminals and supply voltage	Yes
Ambient conditions	
Ambient temperature during operation	
<ul style="list-style-type: none"> horizontal installation, min. 	0 °C; No condensation
<ul style="list-style-type: none"> horizontal installation, max. 	60 °C
<ul style="list-style-type: none"> vertical installation, min. 	0 °C; No condensation
<ul style="list-style-type: none"> vertical installation, max. 	50 °C
<ul style="list-style-type: none"> Vertical installation, min. 	0 °C; No condensation
<ul style="list-style-type: none"> Vertical installation, max. 	50 °C
<ul style="list-style-type: none"> Horizontal installation, min. 	0 °C; No condensation
<ul style="list-style-type: none"> Horizontal installation, max. 	50 °C
Altitude during operation relating to sea level	
<ul style="list-style-type: none"> Ambient air temperature-barometric pressure-altitude 	On request: Ambient temperatures lower than 0 °C (without condensation) and/or installation altitudes greater than 2 000 m

6.6 PotDis-TB

Article number	6ES7193-6TP00-0TP0
Accessories	
Color coding labels	
<ul style="list-style-type: none"> • for process terminals 	CC10
Connection method	
Terminals	
<ul style="list-style-type: none"> • Terminal type 	Push-in terminal
<ul style="list-style-type: none"> • Conductor cross-section, min. 	0.14 mm ² ; 0.2 mm ² without wire end ferrule
<ul style="list-style-type: none"> • Conductor cross-section, max. 	2.5 mm ² ; 1.5 mm ² with wire end ferrule
<ul style="list-style-type: none"> • Number of process terminals to I/O module 	16
<ul style="list-style-type: none"> • Number of terminals to AUX bus 	0
<ul style="list-style-type: none"> • Number of add-on terminals 	0
<ul style="list-style-type: none"> • Number of terminals with connection to P1 and P2 bus 	2
Dimensions	
Width	15 mm
Height	74 mm
Depth	34 mm
Weights	
Weight, approx.	24 g

Dimension drawings of I/O modules

Dimension drawing BU15-P16+A10+2D, BU15-P16+A10+2B, BU15-P16+A0+12D/T, BU15-P16+A0+12B/T

The figure below shows the dimension drawing of the BU15-P16+A10+2D with plugged-in I/O module as an example.

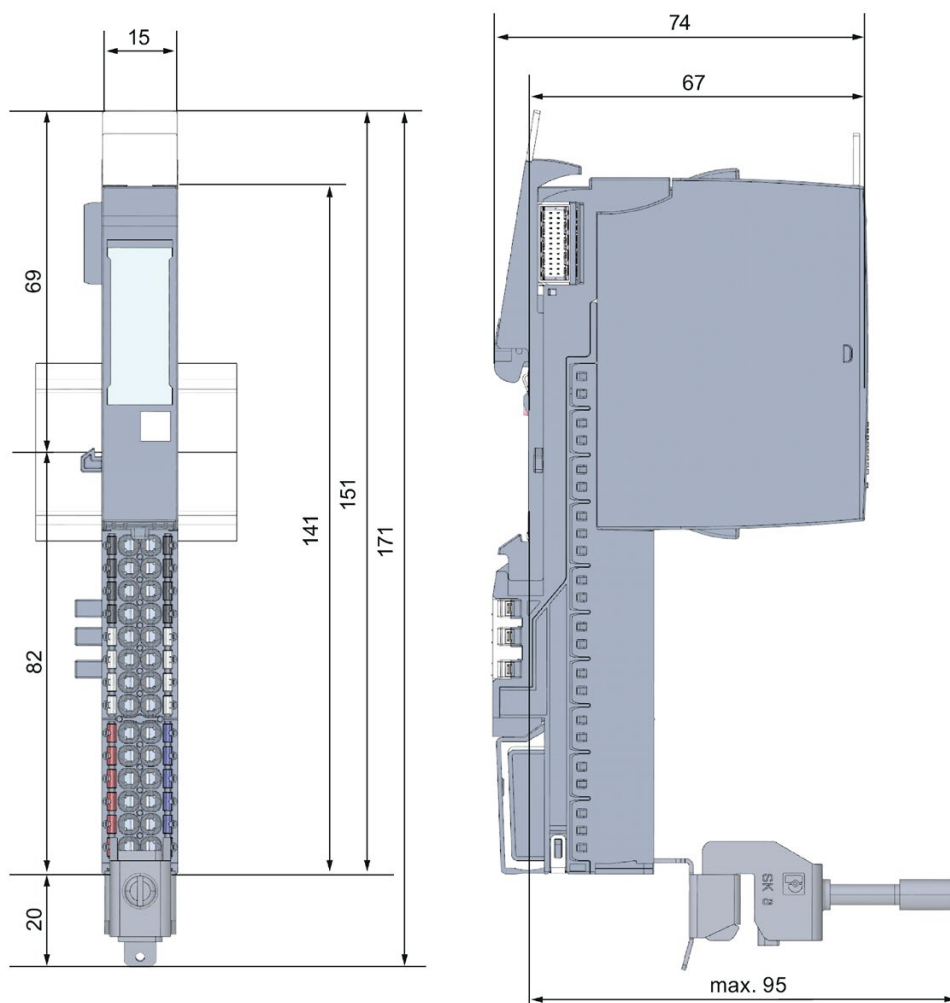

Figure A-1 Dimension drawing BU15-P16+A10+2D

Dimension drawing BU15-P16+A0+2D, BU15-P16+A0+2B, BU15-P16+A0+2D/T, BU15-P16+A0+2B/T

The figure below shows the dimension drawing of the BU15-P16+A0+2D with plugged-in I/O module as an example.

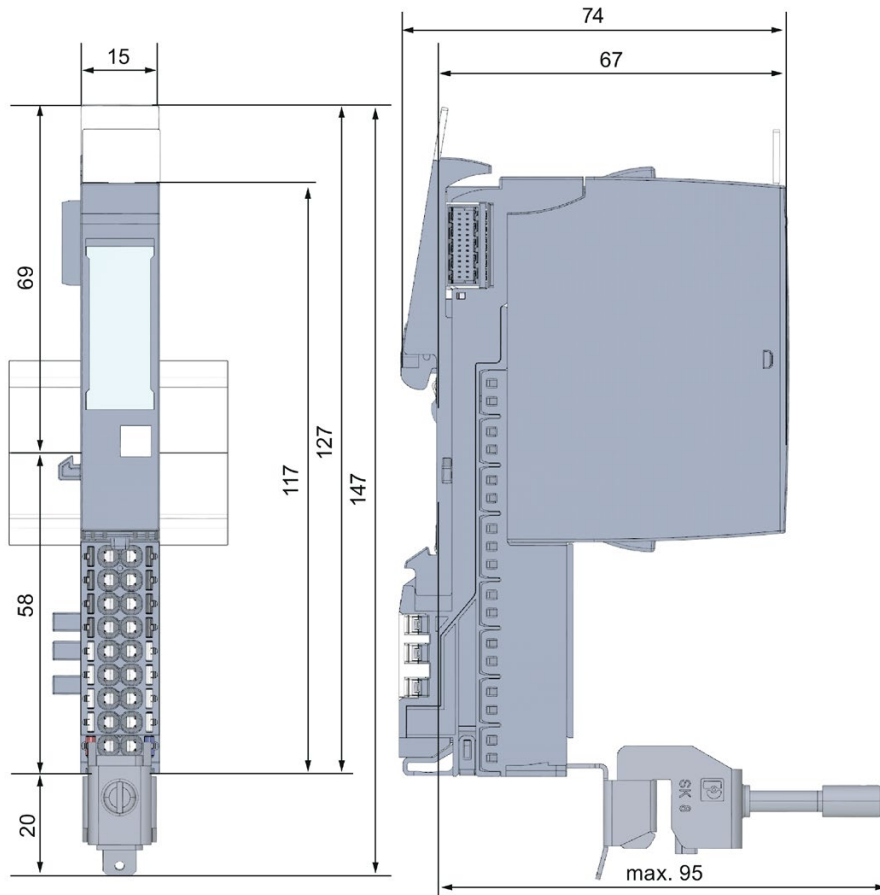

Figure A-2 Dimension drawing BU15-P16+A0+2D

Dimension drawing BU20-P6+A2+4D, BU20-P6+A2+4B, BU20-P12+A4+0B, BU20-P12+A0+0B, BU20-P12+A0+4B, BU20-P8+A4+0B

The figure below shows the dimension drawing of the BU20-P12+A4+0B with plugged-in I/O module as an example.

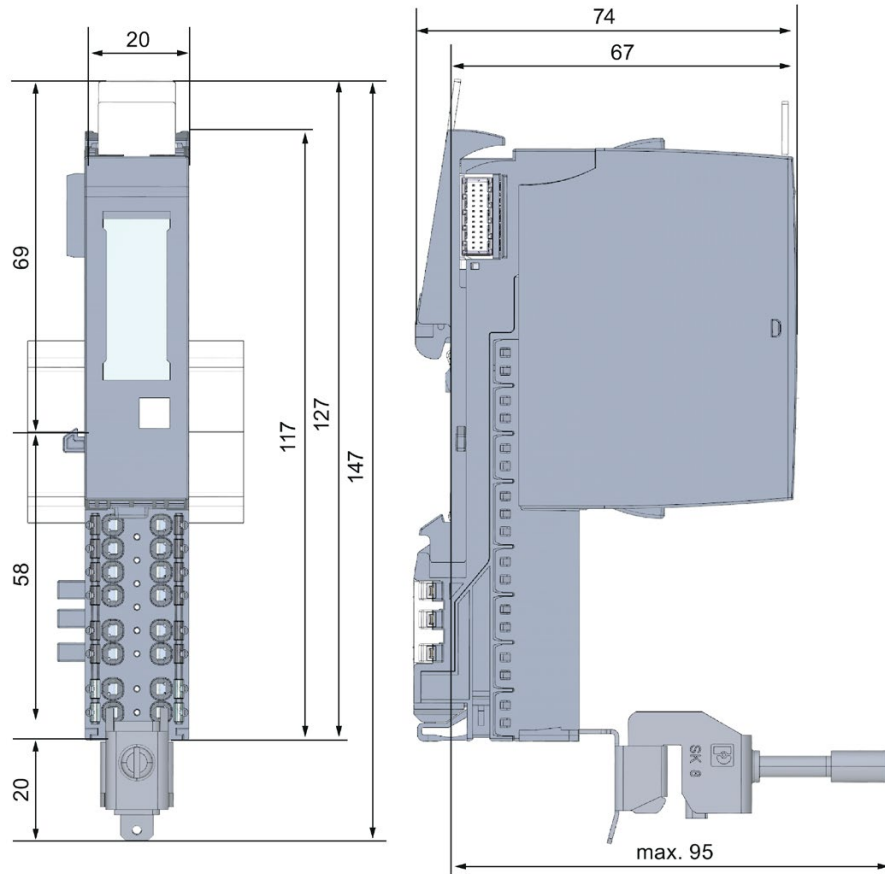

Figure A-3 Dimension drawing BU20-P12+A4+0B

Dimension drawing test probe for measurement tap

The figure below shows the dimension drawing of a suitable test probe for measurement tap at the BaseUnit.

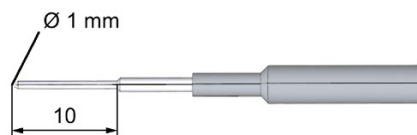

Figure A-4 Dimension drawing test probe

Dimension drawings of motor starters

Dimension drawing BU30-MS1, BU30-MS2, BU30-MS3, BU30-MS4, BU30-MS5, BU30-MS6

The figure below shows the dimension drawing of the BU30-MS-1 with plugged-in motor starter module as an example.

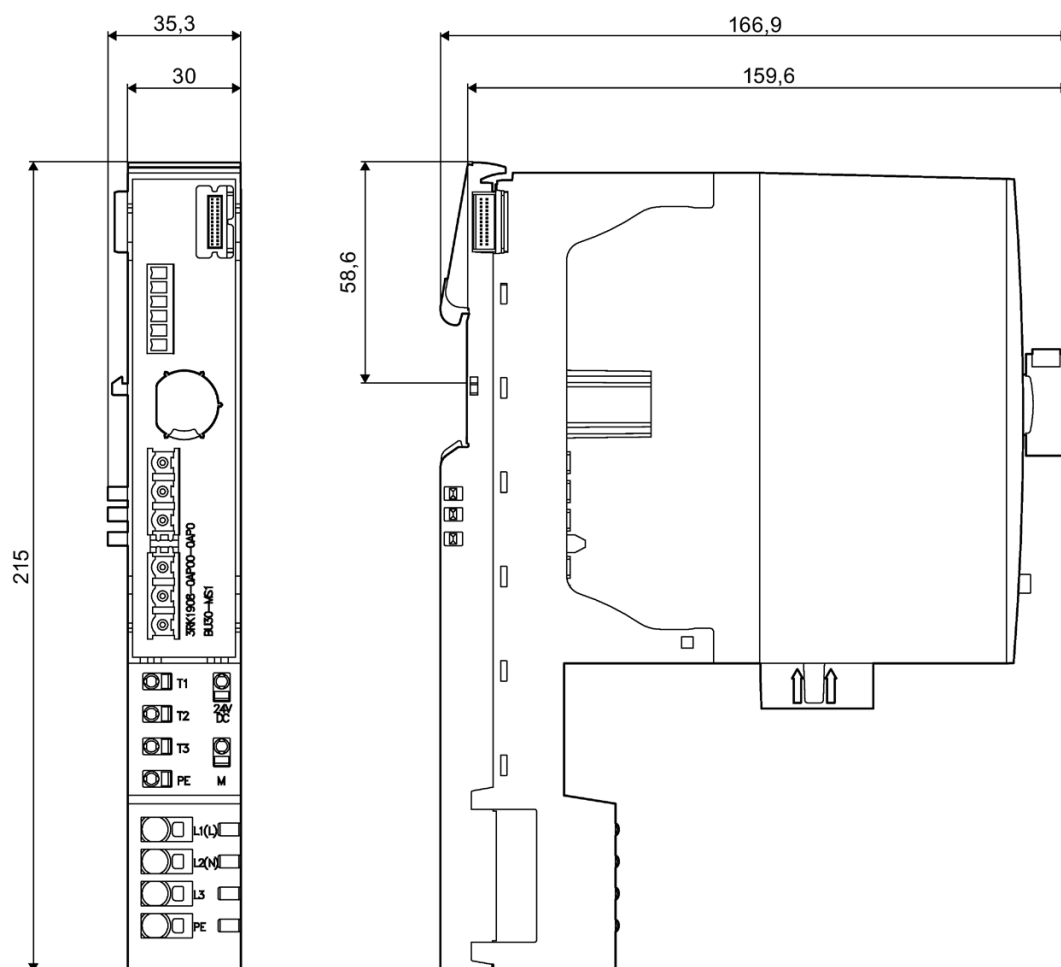

Figure B-1 Dimension drawing BU30-MS1

Dimension drawings of the potential distributor modules

7

Dimension drawing

The figure below shows the dimension drawing of the PotDis-BU-P1/B-R with plugged-in PotDis-TB-P1-R terminal block.

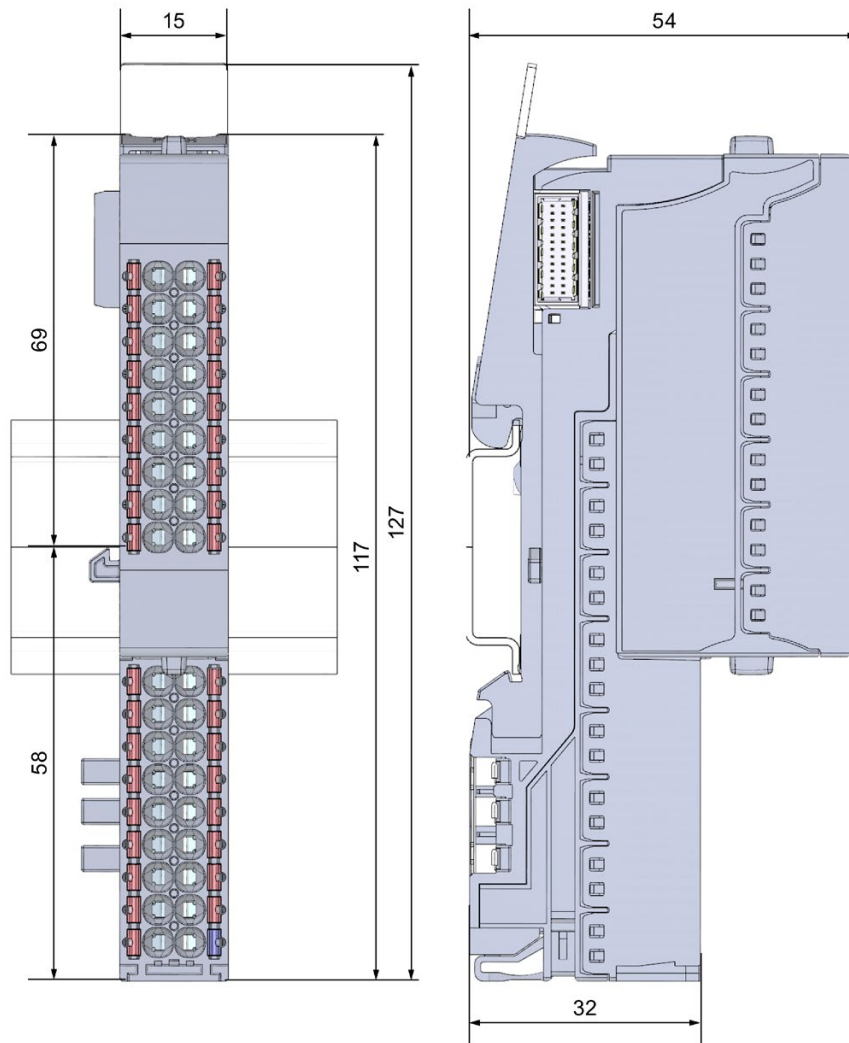

Figure 7-1 Dimension drawing of PotDis BU-P1/B-R with plugged-in terminal block