

Operating Guide

VLT® Micro Drive FC 51

Without RFI filter





Danfoss A/S

6430 Nordborg
Denmark
CVR nr.: 20 16 57 15

Telephone: +45 7488 2222
Fax: +45 7449 0949

EU DECLARATION OF CONFORMITY

Danfoss A/S
Danfoss Drives A/S

declares under our sole responsibility that the

Product category: Frequency Converter

Type designation(s): FC-051PXXYY*****

Character XXX: K18, K25, K37, K55, K75, 1K5, 2K2, 3K0, 3K7, 4K0, 5K5, 7K5, 11K, 15K, 18K, 22K.
Character YY: S2, T2, T4.

* may be any number or letter indicating drive options which do not impact this DoC.

The meaning of the 39 characters in the type code string can be found in appendix 00729776.

Covered by this declaration is in conformity with the following directive(s), standard(s) or other normative document(s), provided that the product is used in accordance with our instructions.

Low Voltage Directive 2014/35/EU

EN61800-5-1: 2007 + A1:2017 Adjustable speed electrical power drive systems – Part 5-1:
Safety requirements – Electrical, thermal and energy.

EMC Directive 2014/30/EU

EN61800-3:2004 + A1:2012 Adjustable speed electrical power drive systems – Part 3: EMC
requirements and specific test methods.

RoHS Directive 2011/65/EU including amendment 2015/863.

EN63000:2018 Technical documentation for the assessment of electrical and
electronic products with respect to the restriction of
hazardous substances

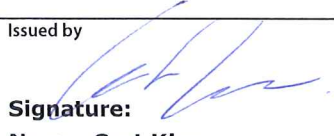
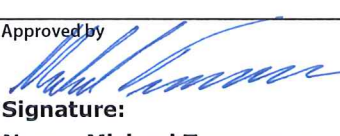
Date: 2020.09.15 Place of issue:	Issued by  Signature: Name: Gert Kjær Title: Senior Director, GDE	Date: 2020.09.15 Place of issue:	Approved by  Signature: Name: Michael Termansen Title: VP, PD Center Denmark
Graasten, DK		Graasten, DK	

Danfoss only vouches for the correctness of the English version of this declaration. In the event of the declaration being translated into any other language, the translator concerned shall be liable for the correctness of the translation

Contents

1	Introduction	5
1.1	Purpose of this Operating Guide	5
1.2	Trademarks	5
1.3	Additional Resources	5
1.4	Type Approvals and Certifications	5
1.5	IT Mains	5
1.6	Disposal	5
2	Safety	6
2.1	Safety Symbols	6
2.2	Qualified Personnel	6
2.3	Safety Precautions	6
2.4	Safety Instructions	8
3	Installation	9
3.1	Before Commencing Repair Work	9
3.2	Side-by-side Installation	9
3.3	Mechanical Dimensions	9
3.4	Tightening of Terminals	10
3.5	Fuses	10
3.5.1	Branch Circuit Protection	10
3.5.2	Short-circuit Protection	10
3.5.3	Overcurrent Protection	10
3.5.4	Non-UL Compliance	10
3.5.5	Recommendation of Fuses	11
3.6	Connecting to Mains and Motor	11
3.7	Control Terminals	12
3.8	Power Circuit	15
3.9	Load Sharing/Brake	15
4	Programming	17
4.1	Local Control Panel (LCP)	17
4.2	Programming on Automatic Motor Tuning (AMT)	18
4.2.1	Mode 1	18
4.2.2	Mode 2	18
5	Parameter Overview	19
5.1	Parameter List	19

6	Troubleshooting	24
6.1	Warnings and Alarms	24
7	Specifications	26
7.1	Mains Supply 1x200–240 V AC	26
7.2	Mains Supply 3x380–480 V AC	26
8	General Technical Data	29
8.1	Protection and Features	29
8.2	Mains Supply (L1/L, L2, L3/N)	29
8.3	Motor Output (U, V, W)	29
8.4	Cable Length and Cross-section	29
8.5	Digital Inputs (Pulse/encoder Inputs)	29
8.6	Analog Inputs	30
8.7	Analog Outputs	30
8.8	Control Card, RS485 Serial Communication	30
8.9	Control Card, 24 V DC Output	30
8.10	Relay Output	30
8.11	Control Card, +10 V DC Output	31
8.12	Surroundings	31
9	Special Conditions	32
9.1	Derating for Ambient Temperature	32
9.2	Derating for Low Air Pressure	32
9.3	Derating for Running at Low Speeds	32
10	Options and Spare Parts	33
10.1	Options and Spare Parts	33

1 Introduction

1.1 Purpose of this Operating Guide

This Operating Guide provides information for safe installation and commissioning of the product. It is intended for use by qualified personnel. Read and follow the instructions to use the drive safely and professionally. Pay particular attention to the safety instructions and general warnings. Always keep this Operating Guide available with the drive.

1.2 Trademarks

VLT® is a registered trademark for Danfoss A/S.

1.3 Additional Resources

Other resources are available to understand advanced drive functions and programming.

- The Programming Guide provides greater detail on working with parameters and many application examples.
- The Design Guide provides detailed information about capabilities and functionality to design motor control systems.
- Instructions for operation with optional equipment and replacement of components.

Supplementary publications and manuals are available at: www.danfoss.com.

1.4 Type Approvals and Certifications



1.5 IT Mains

NOTICE

IT MAINS

Installation on isolated mains source, that is IT mains. Maximum supply voltage allowed when connected to mains: 440 V.

As an option, Danfoss offers recommended line filters for improved harmonics performance. See *chapter Options and Spare Parts*.

1.6 Disposal



Do not dispose of equipment containing electrical components together with domestic waste.
Collect it separately in accordance with local and currently valid legislation.

2 Safety

2.1 Safety Symbols

The following symbols are used in this manual:

⚠ D A N G E R ⚠

Indicates a hazardous situation which, if not avoided, will result in death or serious injury.

⚠ W A R N I N G ⚠

Indicates a hazardous situation which, if not avoided, could result in death or serious injury.

⚠ C A U T I O N ⚠

Indicates a hazardous situation which, if not avoided, could result in minor or moderate injury.

N O T I C E

Indicates information considered important, but not hazard-related (for example, messages relating to property damage).

2.2 Qualified Personnel

To allow trouble-free and safe operation of the unit, only qualified personnel with proven skills are allowed to transport, store, assemble, install, program, commission, maintain, and decommission this equipment.

Persons with proven skills:

- Are qualified electrical engineers, or persons who have received training from qualified electrical engineers and are suitably experienced to operate devices, systems, plant, and machinery in accordance with pertinent laws and regulations.
- Are familiar with the basic regulations concerning health and safety/accident prevention.
- Have read and understood the safety guidelines given in all manuals provided with the unit, especially the instructions given in the Operating Guide.
- Have good knowledge of the generic and specialist standards applicable to the specific application.

2.3 Safety Precautions

⚠ W A R N I N G ⚠

HIGH VOLTAGE

AC drives contain high voltage when connected to AC mains input, DC supply, or load sharing. Failure to perform installation, start-up, and maintenance by qualified personnel can result in death or serious injury.

- Only qualified personnel must perform installation, start-up, and maintenance.

⚠ W A R N I N G ⚠

UNINTENDED START

When the drive is connected to the AC mains, DC supply, or load sharing, the motor may start at any time, causing risk of death, serious injury, and equipment or property damage. The motor may start by activation of an external switch, a fieldbus command, an input reference signal from the LCP or LOP, via remote operation using MCT 10 Set-up software, or after a cleared fault condition.

- Press [Off] on the LCP before programming parameters.
- Disconnect the drive from the mains whenever personal safety considerations make it necessary to avoid unintended motor start.
- Check that the drive, motor, and any driven equipment are in operational readiness.

N O T I C E

The [Off/Reset] key is not a safety switch. It does not disconnect the drive from mains.

⚠ W A R N I N G ⚠

DISCHARGE TIME

The drive contains DC-link capacitors, which can remain charged even when the drive is not powered. High voltage can be present even when the warning indicator lights are off.

Failure to wait the specified time after power has been removed before performing service or repair work could result in death or serious injury.

- Stop the motor.
- Disconnect AC mains, permanent magnet type motors, and remote DC-link supplies, including battery back-ups, UPS, and DC-link connections to other drives.
- Wait for the capacitors to discharge fully. The minimum waiting time is specified in the table *Discharge time* and is also visible on the nameplate on top of the drive.
- Before performing any service or repair work, use an appropriate voltage measuring device to make sure that the capacitors are fully discharged.

Table 1: Discharge Time

Size	Minimum waiting time (minutes)
M1, M2, and M3	4
M4 and M5	15

Leakage current (>3.5 mA)

Follow national and local codes regarding protective earthing of equipment with a leakage current >3.5 mA. AC drive technology implies high frequency switching at high power. This generates a leakage current in the ground connection. A fault current in the drive at the output power terminals might contain a DC component, which can charge the filter capacitors and cause a transient ground current. The ground leakage current depends on various system configurations including RFI filtering, shielded motor cables, and drive power.

EN/IEC61800-5-1 (Power Drive System Product Standard) requires special care if the leakage current exceeds 3.5 mA. Reinforce Grounding in 1 of the following ways:

- Grounding wire of at least 10 mm² (8 AWG).
- 2 separate ground wires both complying with the dimensioning rules.

See EN 60364-5-54 § 543.7 for further information.

Using RCDs

Where residual current devices (RCDs), also known as earth leakage circuit breakers (ELCBs), are used, comply with the following:

- Use RCDs of type B that can detect AC and DC currents.
- Use RCDs with an inrush delay to prevent faults due to transient ground currents.
- Dimension RCDs according to the system configuration and environmental considerations.

Motor thermal protection

Motor overload protection is possible by setting *parameter 1-90 Motor Thermal Protection* to [4] *ETR trip*. For the North American market: Implemented ETR function provides class 20 motor overload protection, in accordance with NEC.

Installation at high altitudes

For altitudes above 2000 m (6562 ft), contact Danfoss regarding PELV.

2.4 Safety Instructions

- Make sure that the drive is properly grounded.
- Do not remove mains connections, motor connections, or other power connections while the drive is connected to power.
- Protect users against supply voltage.
- Protect the motor against overloading according to national and local regulations.

3 Installation

3.1 Before Commencing Repair Work

Procedure

1. Disconnect the VLT® Micro DriveFC 51 from mains (and external DC supply, if present).
2. Wait for 4 minutes (M1, M2, and M3) and 15 minutes (M4 and M5) for discharge of the DC-link.
3. Disconnect the DC bus terminals and the brake terminals (if present).
4. Remove the motor cable.

3.2 Side-by-side Installation

The drive can be mounted side by side for IP20 rating units and requires 100 mm (3.9 in) clearance above and below for cooling. Refer to *chapter Specifications* for details on environmental ratings of the drive.

3.3 Mechanical Dimensions

A template for drilling is found on the flap of the packaging.

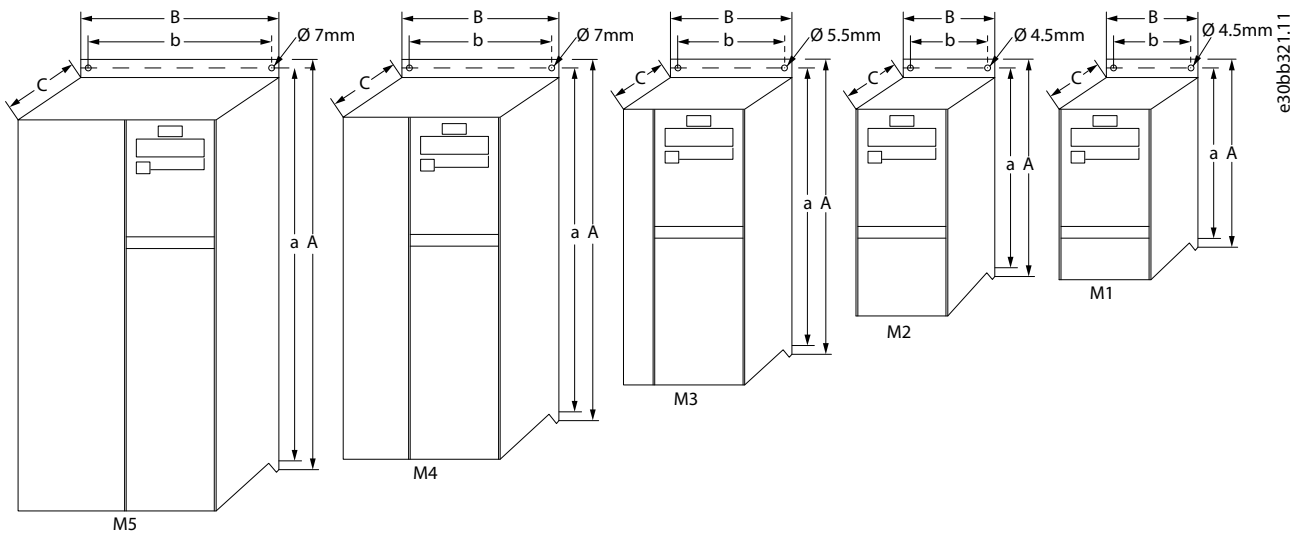

Illustration 1: Mechanical Dimensions

Table 2: Mechanical Dimensions

	Power [kW (hp)]		Height [mm (in)]			Width [mm (in)]		Depth [mm (in)] ⁽¹⁾	Maximum weight [kg]
	1x200–240 V	3x380–480 V	A	A (including decoupling plate)	a	B	b		
M1	0.18–0.75 (0.24–1.0)	0.37–0.75 (0.5–1.0)	150 (5.9)	205 (8.1)	140.4 (5.5)	70 (2.8)	55 (2.2)	148 (5.8)	1.0
M2	1.5 (2.0)	1.5–2.2 (2.0–3.0)	176 (6.9)	230 (9.1)	166.4 (6.6)	75 (3.0)	59 (2.3)	168 (6.6)	1.5
M3	2.2 (3.0)	3.0–7.5 (4.0–10)	239 (9.4)	294 (11.6)	226 (8.9)	90 (3.5)	69 (2.7)	194 (7.6)	2.8
M4	–	11.0–15.0 (15–20)	292 (11.5)	347.5 (13.7)	272.4 (10.7)	125 (4.9)	97 (3.8)	241 (9.5)	5.6

	Power [kW (hp)]		Height [mm (in)]			Width [mm (in)]		Depth [mm (in)] ⁽¹⁾	Maximum weight
M5	–	18.5–22.0 (25–30)	335 (13.2)	387.5 (15.3)	315 (12.4)	165 (6.5)	140 (5.5)	248 (9.8)	9.1

¹ For LCP with potentiometer, add 7.6 mm (0.3 in).

3.4 Tightening of Terminals

N O T I C E

All cabling must comply with national and local regulations on cable cross-sections and ambient temperature. Copper conductors required, 60–75 °C (140–167 °F) recommended.

Table 3: Tightening of Terminals

Enclosure	Power [kW (hp)]		Torque [Nm (in-lb)]					
	1x200–240 V	3x380–480 V	Line	Motor	DC connection/brake	Control terminals	Ground	Relay
M1	0.18–0.75 (0.24–1.0)	0.37–0.75 (0.5–1.0)	0.8 (7.1)	0.7 (6.2)	Spade ⁽¹⁾	0.15 (1.3)	3 (26.6)	0.5 (4.4)
M2	1.5 (2.0)	1.5–2.2 (2.0–3.0)	0.8 (7.1)	0.7 (6.2)	Spade ⁽¹⁾	0.15 (1.3)	3 (26.6)	0.5 (4.4)
M3	2.2 (3.0)	3.0–7.5 (4.0–10)	0.8 (7.1)	0.7 (6.2)	Spade ⁽¹⁾	0.15 (1.3)	3 (26.6)	0.5 (4.4)
M4	–	11.0–15.0 (15–20)	1.3 (11.5)	1.3 (11.5)	1.3 (11.5)	0.15 (1.3)	3 (26.6)	0.5 (4.4)
M5	–	18.5–22.0 (25–30)	1.3 (11.5)	1.3 (11.5)	1.3 (11.5)	0.15 (1.3)	3 (26.6)	0.5 (4.4)

¹ Spade connectors (6.3 mm (0.25 in) Faston plugs).

3.5 Fuses

3.5.1 Branch Circuit Protection

To prevent fire hazards, protect the branch circuits in an installation, switch gear, machines, and so on, against short circuits and overcurrent. Follow national and local regulations.

3.5.2 Short-circuit Protection

Use the Danfoss recommended fuses to protect service personnel or other equipment if there is an internal failure in the unit or short circuit on DC-link. If there is a short circuit on the motor or brake output, the drive provides full short-circuit protection.

3.5.3 Overcurrent Protection

To avoid overheating of the cables in the installation, provide overload protection. Always carry out overcurrent protection according to national regulations. Fuses must be designed for protection in a circuit capable of supplying a maximum of 100000 A_{rms} (symmetrical), 480 V maximum.

3.5.4 Non-UL Compliance

If UL/cUL is not to be complied with, use the fuses mentioned in this chapter, which ensure compliance with EN50178/IEC61800-5-1. If there is a malfunction, not following the fuse recommendation may result in damage to the drive and the installation.

3.5.5 Recommendation of Fuses

Table 4: Fuses

FC 51	Maximum fuses non-UL
kW	Type gG
1x200–240 V	
0K18–0K37	16A
0K75	25A
1K5	35A
2K2	50A
3x380–480 V	
0K37–0K75	10A
1K5	16A
2K2	20A
3K0	40A
4K0	40A
5K5	40A
7K5	40A
11K0	63A
15K0	63A
18K5	80A
22K0	80A

3.6 Connecting to Mains and Motor

The drive is designed to operate all standard 3-phased asynchronous motors.

The drive is designed to accept mains/ motor cables with a maximum cross-section of 4 mm²/10 AWG (M1, M2, and M3), and a maximum cross-section of 16 mm²/6 AWG (M4 and M5).

- Use a shielded/armored motor cable to comply with EMC emission specifications, and connect this cable to both the decoupling plate and the motor metal.
- Keep motor cable as short as possible to reduce the noise level and leakage currents.
- For further details on mounting of the decoupling plate, see VLT® Micro DriveFC 51 Decoupling Mounting Plate Instructions.
- Also see the chapter EMC-correct Electrical Installation in the VLT® Micro DriveFC 51 Design Guide.

Mounting of Ground Cable, Mains, and Motor Wires

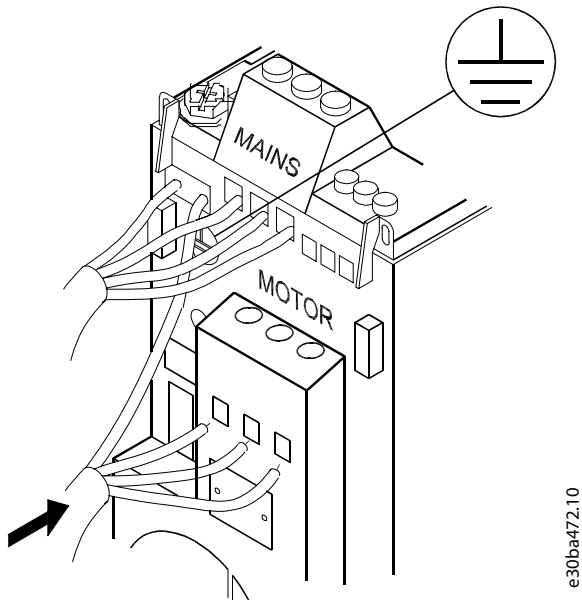

e30ba472.10

Illustration 2: Mounting of Ground Cable, Mains, and Motor Wires

- Mount the ground wires to PE terminal.
- Connect motor to terminals U, V, and W.
- Mount mains supply to terminals L1/L, L2, and L3/N (3-phase) or L1/L and L3/N (single-phase) and tighten.

3.7 Control Terminals

All control cable terminals are located underneath the terminal cover in front of the drive. Remove the terminal cover using a screwdriver.

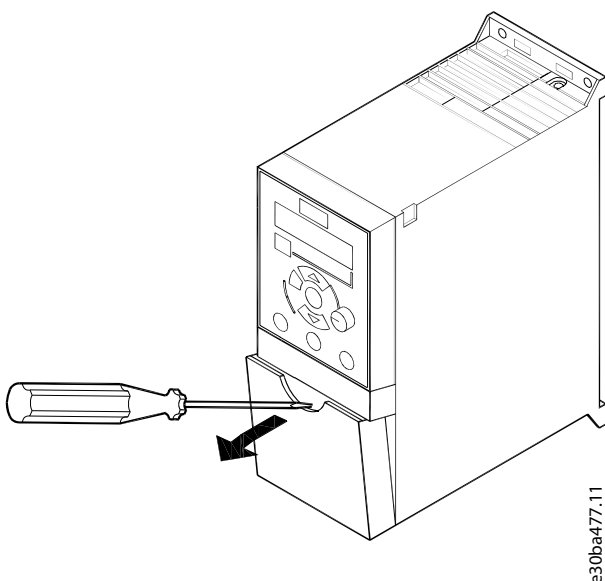

e30ba477.11

Illustration 3: Removing Terminal Cover

NOTICE

See the back of the terminal cover for outlines of control terminals and switches.

NOTICE

Do not operate switches with power on the drive.

NOTICE

Set parameter 6-19 Terminal 53 Mode according to Switch 4 position.

Table 5: Settings for S200 Switches 1–4

Switch 1	Off=PNP terminals 29 ⁽¹⁾
	On=NPN terminals 29
Switch 2	Off=PNP terminal 18, 19, 27, and 33 ⁽¹⁾
	On=NPN terminal 18, 19, 27, and 33
Switch 3	No function
Switch 4	Off=Terminal 53 0–10 V ⁽¹⁾
	On=Terminal 53 0/4-20 mA

¹ This is the default setting.

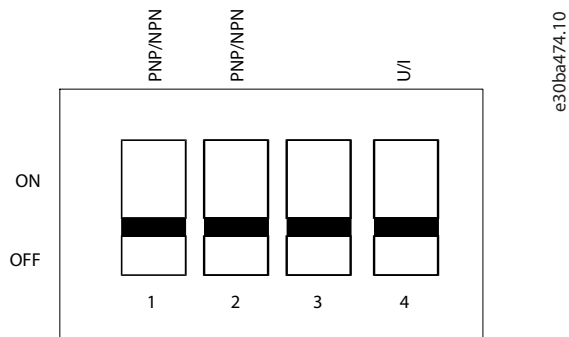
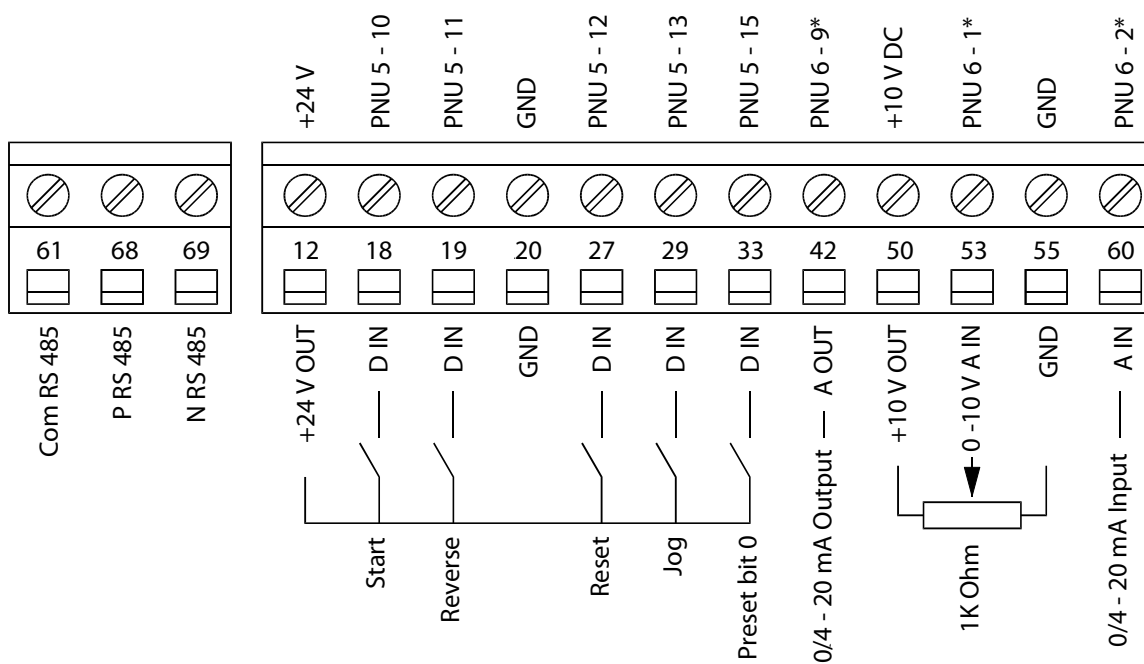

Illustration 4: S200 Switches 1–4

The following illustration shows all control terminals of the drive. Applying start (terminal 18) and an analog reference (terminal 53 or 60) make the drive run.



e30ba473.10

Illustration 5: Overview of Control Terminals in PNP-configuration with Factory Setting

3.8 Power Circuit

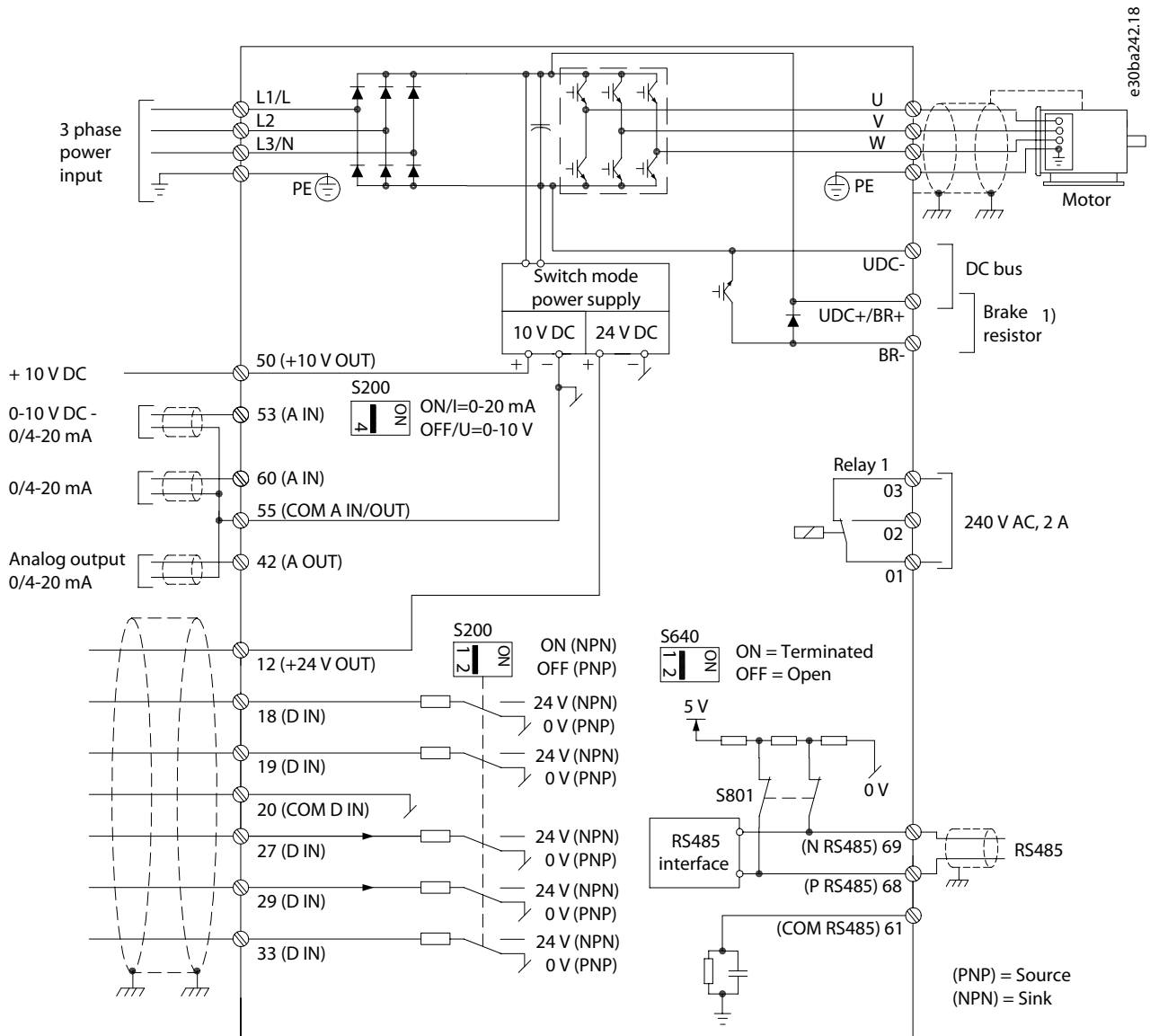

Illustration 6: Diagram Showing all Electrical Terminals

1) Brakes (BR+ and BR-) are not applicable for enclosure size M1.

For information about brake resistors, see VLT® Brake Resistor MCE 101 Design Guide.

Improved power factor and EMC performance can be achieved by installing optional Danfoss line filters.

Danfoss power filters can also be used for load sharing. For more information about load sharing, see VLT® Micro DriveFC 51 Load Sharing application note.

3.9 Load Sharing/Brake

Use 6.3 mm (0.25 in) insulated Faston plugs designed for high voltage for DC (load sharing and brake).

Contact Danfoss or see Load sharing instruction VLT® 5000 for load sharing and VLT® 2800/5000/5000 FLUX/FCD 300 Brake for brake.

Load sharing

Connect terminals -UDC and +UDC/+BR.

Brake

Connect terminals -BR and +UDC/+BR (not applicable for enclosure size M1).

N O T I C E

Voltage levels of up to 850 V DC may occur between terminals +UDC/+BR and -UDC. Not short circuit protected.

4 Programming

4.1 Local Control Panel (LCP)

For detailed information on programming, see VLT® Micro DriveFC 51 Programming Guide.

NOTICE

The drive can also be programmed from a PC via RS485 com-port by installing the MCT 10 Set-up Software.

- This software can either be ordered using code number 130B1000 or downloaded from the Danfoss web site: www.danfoss.com.

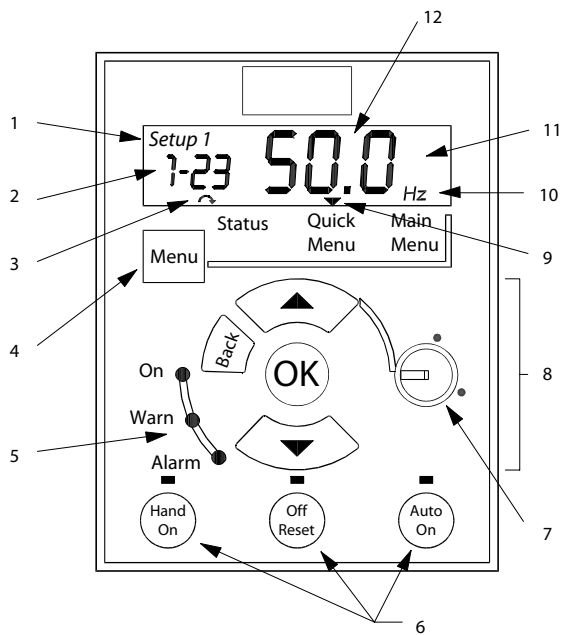

e30ba605.13

Illustration 7: Description of LCP Keys and Display

1	Set-up number	7	Potentiometer (LCP 12)
2	Parameter number	8	Navigation keys
3	Motor direction	9	Selected menu
4	Menu key	10	Unit
5	Indicator lights	11	Numeric display
6	Operation keys and LED	12	Value

Press [Menu] to select 1 of the following menus:

Status

For readouts only.

Quick Menu

For access to Quick Menus 1 and 2.

Main Menu

For access to all parameters.

Navigation keys

[Back]: For moving to the previous step or layer in the navigation structure.

[▲] [▼]: For manoeuvring between parameter groups, parameters, and within parameters.

[OK]: For selecting a parameter and for accepting changes to parameter settings.

Pressing [OK] for more than 1 s enters Adjust mode. In Adjust mode, it is possible to make fast adjustment by pressing [▲] [▼] combined with [OK].

Press [▲] [▼] to change value. Press [OK] to shift between digits quickly.

To exit Adjust mode, press [OK] more than 1 s again with changes saving or press [Back] without changes saving.

Operation keys

A yellow indicator light above the operation keys indicates the active key.

[Hand On]: Starts the motor and enables control of the drive via the LCP.

[Off/Reset]: The motor stops. If in alarm mode, the motor resets.

[Auto On]: The drive is controlled either via control terminals or serial communication.

[Potentiometer] (LCP12): The potentiometer works in 2 ways depending on the mode in which the drive is running.

In auto-on mode, the potentiometer acts as an extra programmable analog input.

In hand-on mode, the potentiometer controls local reference.

4.2 Programming on Automatic Motor Tuning (AMT)

Run AMT to optimize compatibility between the drive and the motor in VVC⁺ mode.

- The drive builds a mathematical model of the motor for regulating output motor current thus enhancing motor performance.
- Run this procedure on a cold motor for best results. To run AMT, use the numeric LCP (NLCP). There are 2 AMT modes for drives.

NOTICE

In mode 2, the rotor rotates during the AMT progress.

- Do not add any load on the motor in this AMT progress.

4.2.1 Mode 1

Procedure

1. Enter the main menu.
2. Go to *parameter group 1-** Load and Motor*.
3. Press [OK].
4. Set motor parameters using nameplate data for *parameter group 1-2* Motor Data*.
5. Go to *parameter 1-29 Automatic Motor Tuning (AMT)*.
6. Press [OK].
7. Select [2] *Enable AMT*.
8. Press [OK].
9. The test runs automatically and indicates when it is complete.

4.2.2 Mode 2

Procedure

1. Enter the main menu.
2. Go to *parameter group 1-** Load and Motor*.
3. Press [OK].
4. Set motor parameters using nameplate data for *parameter group 1-2* Motor Data*.
5. Go to *parameter 1-29 Automatic Motor Tuning (AMT)*.
6. Press [OK].
7. Select [3] *Complete AMT with Rotating motor*.
8. Press [OK].
9. The test runs automatically and indicates when it is complete.

5 Parameter Overview

5.1 Parameter List

Table 6: Parameter List

0-** Operation/Display	[1] Copy from set-up 1	[20] 30.00 kW/40.00 hp	1-7* Start Adjustments
0-0* Basic Settings	[2] Copy from set-up 2	1-22 Motor Voltage	1-71 Start Delay
0-03 Regional Settings	[9] Copy from Factory set-up	50-999 V *230-400 V	0.0-10.0 s *0.0 s
[0] International	0-6 Password	1-23 Motor Frequency	1-72 Start Function
[1] US	0-60 (Main) Menu Password	20-400 Hz *50 Hz	[0] DC hold/delay time
0-04 Oper. State at Power-up (Hand)	0-999 *0	1-24 Motor Current	[1] DC brake/delay time
[0] Resume	0-61 Access to Main/Quick Menu w/o Password	0.01-100.00 A *Motortype dep.	*[2] Coast/delay time
*[1] Forced stop, ref=old	*[0] Full access	1-25 Motor Nominal Speed	1-73 Flying Start
[2] Forced stop, ref=0	[1] LCP:Read Only	100-9999 rpm *Motortype dep.	*[0] Disabled
0-1* Set-up Handling	[2] LCP:No Access	1-29 Automatic Motor Tuning (AMT)	[1] Enabled
0-10 Active Set-up	1-** Load/Motor	*[0] Off	1-8* Stop Adjustments
[1] Set-up 1	1-0 General Settings	[2] Enable AMT	1-80 Function at Stop
[2] Set-up 2	1-00 Configuration Mode	[3] Complete AMT with Rotating motor	*[0] Coast
[9] Multi Set-up	*[0] Speed open loop	[3] Complete AMT with Rotating motor	[1] DC hold
0-11 Edit Set-up	[3] Process	1-3* Adv. Motor Data	1-82 Min Speed for Funct. at Stop [Hz]
*[1] Set-up 1	1-01 Motor Control Principle	1-30 Stator Resistance (Rs)	0.0-20.0 Hz *0.0 Hz
[2] Set-up 2	[0] U/f	[Ohm] * Dep. on motor data	1-9*Motor Temperature
[9] Active Set-up	*[1] VVC+	1-33 Stator Leakage Reactance (X1)	1-90 Motor Thermal Protection
0-12 Link Set-ups	1-03 Torque Characteristics	[Ohm] * Dep. on motor data	*[0] No protection
[0] Not Linked	*[0] Constant torque	1-35 Main Reactance (Xh)	[1] Thermistor warning
*[20] Linked	[2] Automatic Energy Optim.	[Ohm] * Dep. on motor data	[2] Thermistor trip
0-31 Custom Readout Min Scale	1-05 Local Mode Configuration	1-5* Load Indep. Setting	[3] Etr warning
0.00-9999.00 * 0.00	[0] Speed Open Loop	1-50 Motor Magnetisation at 0 Speed	[4] Etr trip
0-32 Custom Readout Max Scale	*[2] As config in par. 1-00	0-300% *100%	1-93 Thermistor Resource
0.00-9999.00 * 100.0	1-2* Motor Data	1-52 Min Speed Norm. Magnet. [Hz]	*[0] None
0-4* LCP Keypad	1-20 Motor Power [kW] [hp]	0.0-10.0 Hz *0.0Hz	[1] Analog input 53
0-40 [Hand on] Key on LCP	[1] 0.09 kW/0.12 hp	1-55 U/f Characteristic - U	[6] Digital input 29
[0] Disabled	[2] 0.12 kW/0.16 hp	0-999.9 V	2-** Brakes
[1] Enabled	[3] 0.18 kW/0.25 hp	1-56 U/f Characteristic - F	2-0 DC-Brake
0-41 [Off / Reset] Key on LCP	[4] 0.25 kW/0.33 hp	0-400 Hz	2-00 DC Hold Current
[0] Disable All	[5] 0.37 kW/0.50 hp	1-6* Load Depen. Setting	0-150% *50%
*[1] Enable All	[6] 0.55 kW/0.75 hp	1-60 Low Speed Load Compensation	2-01 DC Brake Current
[2] Enable Reset Only	[7] 0.75 kW/1.00 hp	0-199% *100%	0-150% *50%
0-42 [Auto on] Key on LCP	[8] 1.10 kW/1.50 hp	1-61 High Speed Load Compensation	2-02 DC Braking Time
[0] Disabled	[9] 1.50 kW/2.00 hp	0-199%*100%	0.0-60.0 s *10.0 s
*[1] Enabled	[10] 2.20 kW/3.00 hp	1-62 Slip Compensation	2-04 DC Brake Cut In Speed
0-5* Copy/Save	[11] 3.00 kW/4.00 hp	-400-399% *100%	0.0-400.0 Hz *0.0Hz
0-50 LCP Copy	[12] 3.70 kW/5.00 hp	1-63 Slip Compensation Time Constant	2-1* Brake Energy Funct.
*[0] No copy	[13] 4.00 kW/5.40 hp	0.05-5.00 s *0.10 s	2-10 Brake Function
[1] All to LCP	[14] 5.50 kW/7.50 hp		*[0] Off
[2] All from LCP	[15] 7.50 kW/10.00 hp		[1] Resistor brake
[3] Size indep. from LCP	[16] 11.00 kW/15.00 hp		[2] AC brake
0-51 Set-up Copy	[17] 15.00 kW/20.00 hp		2-11 Brake Resistor (ohm)
*[0] No copy	[18] 18.50 kW/25.00 hp		Min/Max/default: Powersize dep.
	[19] 22.00 kW/29.50 hp		

Table 7: Parameter List

<p>2-14 Brake Voltage reduce 0 - Powersize dep.* 0</p> <p>2-16 AC Brake, Max current 0-150% *100%</p> <p>2-17 Overvoltage Control *[0] Disabled [1] Enabled (not at stop) [2] Enabled</p> <p>2-2* Mechanical Brake</p> <p>2-20 Release Brake Current 0.00–100.0 A *0.00 A</p> <p>2-22 Activate Brake Speed [Hz] 0.0–400.0 Hz *0.0 Hz</p> <p>3-** Reference / Ramps</p> <p>3-0* Reference Limits</p> <p>3-00 Reference Range *[0] Min - Max [1] -Max - +Max</p> <p>3-02 Minimum Reference -4999–4999 *0.000</p> <p>3-03 Maximum Reference -4999–4999 *50.00</p> <p>3-1* References</p> <p>3-10 Preset Reference -100.0–100.0% *0.00%</p> <p>3-11 Jog Speed [Hz] 0.0–400.0 Hz *5.0 Hz</p> <p>3-12 Catch up/slow Down Value 0.00–100.0% * 0.00%</p> <p>3-14 Preset Relative Reference -100.0–100.0% *0.00%</p> <p>3-15 Reference Resource 1 [0] No function *[1] Analog Input 53 [2] Analog input 60 [8] Pulse input 33 [11] Local bus ref [21] LCP Potentiometer</p> <p>3-16 Reference Resource 2 [0] No function [1] Analog in 53 *[2] Analog in 60 [8] Pulse input 33 *[11] Local bus reference [21] LCP Potentiometer</p> <p>3-17 Reference Resource 3</p>	<p>[0] No function [1] Analog Input 53 [2] Analog input 60 [8] Pulse input 33 *[11] Local bus ref [21] LCP Potentiometer</p> <p>3-18 Relative Scaling Ref. Resource *[0] No function [1] Analog Input 53 [2] Analog input 60 [8] Pulse input 33 [11] Local bus ref [21] LCP Potentiometer</p> <p>3-4* Ramp 1 3-40 Ramp 1 Type *[0] Linear [2] Sine2 ramp</p> <p>3-41 Ramp 1 Ramp up Time 0.05–3600 s *3.00 s (10.00s)⁽¹⁾</p> <p>3-42 Ramp 1 Ramp Down Time 0.05–3600 s *3.00s (10.00s)⁽¹⁾</p> <p>3-5* Ramp 2 3-50 Ramp 2 Type *[0] Linear [2] Sine2 ramp</p> <p>3-51 Ramp 2 Ramp up Time 0.05–3600 s *3.00s (10.00s)⁽¹⁾</p> <p>3-52 Ramp 2 Ramp down Time 0.05–3600 s *3.00s (10.00s)⁽¹⁾</p> <p>3-8* Other Ramps</p> <p>3-80 Jog Ramp Time 0.05–3600 s *3.00s (10.00s)⁽¹⁾</p> <p>3-81 Quick Stop Ramp Time 0.05–3600 s *3.00 s (10.00s)⁽¹⁾</p> <p>4-** Limits/Warnings</p> <p>4-1* Motor Limits</p> <p>4-10 Motor Speed Direction *[0] Clockwise If Par. 1-00 is set to close loop control [1] CounterClockwise *[2] Both if Par. 1-00 is set to open loop control</p> <p>4-12 Motor Speed Low Limit [Hz] 0.0–400.0 Hz *0.0 Hz</p>	<p>4-14 Motor Speed High Limit [Hz] 0.1–400.0 Hz *65.0 Hz</p> <p>4-16 Torque Limit Motor Mode 0–400% *150%</p> <p>4-17 Torque Limit Generator Mode 0–400% *100%</p> <p>4-4* Adj. Warnings 2</p> <p>4-40 Warning Frequency Low 0.00–Value of 4-41 Hz *0.0 Hz</p> <p>4-41 Warning Frequency High Value Value of 4-40–400.0 Hz *400.00 Hz</p> <p>4-5* Adj. Warnings</p> <p>4-50 Warning Current Low 0.00–100.00 A *0.00 A</p> <p>4-51 Warning Current High 0.0–100.00 A *100.00 A</p> <p>4-54 Warning Reference Low -4999.000–Value of 4-55 * -4999.000</p> <p>4-55 Warning Reference High Value of 4-54–4999.000 *4999.000</p> <p>4-56 Warning Feedback Low -4999.000–Value of 4-57 * -4999.000</p> <p>4-57 Warning Feedback High Value of 4-56–4999.000 *4999.000</p> <p>4-58 Missing Motor Phase Function [0] Off *[1] On</p> <p>4-6* Speed Bypass</p> <p>4-61 Bypass Speed From [Hz] 0.0–400.0 Hz *0.0 Hz</p> <p>4-63 Bypass Speed To [Hz] 0.0–400.0 Hz *0.0 Hz</p> <p>5-1* Digital Inputs</p> <p>5-10 Terminal 18 Digital Input [0] No function [1] Reset [2] Coast inverse [3] Coast and reset inv. [4] Quick stop inverse</p>	<p>[5] DC-brake inv. [6] Stop inv *[8] Start [9] Latched start [10] Reversing [11] Start reversing [12] Enable start forward [13] Enable start reverse [14] Jog [16-18] Preset ref bit 0-2 [19] Freeze reference [20] Freeze output [21] Speed up [22] Speed down [23] Set-up select bit 0 [28] Catch up [29] Slow down [34] Ramp bit 0 [60] Counter A (up) [61] Counter A (down) [62] Reset counter A [63] Counter B (up) [64] Counter B (down) [65] Reset counter B</p> <p>5-11 Terminal 19 Digital Input See par. 5-10. * [10] Reversing</p> <p>5-12 Terminal 27 Digital Input See par. 5-10. * [1] Reset</p> <p>5-13 Terminal 29 Digital Input See par. 5-10. * [14] Jog</p> <p>5-15 Terminal 33 Digital Input See par. 5-10. * [16] Preset ref bit 0 [26] Precise Stop Inverse [27] Start, Precise Stop [32] Pulse Input</p> <p>5-3* Digital Outputs</p> <p>5-34 On Delay, Terminal 42 Digital Output 0.00–600.00 s * 0.01 s</p> <p>5-35 Off Delay, Terminal 42 Digital Output 0.00–600.00 s * 0.01 s</p> <p>5-4* Relays</p> <p>5-40 Function Relay *[0] No operation [1] Control ready [2] Drive ready</p>
---	--	---	--

¹ M4 and M5 only.

Table 8: Parameter List

[3] Drive ready, Remote	5-57 Term. 33 Low Ref./Feedb. Value	0.01–10.00 s *0.01 s	7-31 Process PI Anti Windup
[4] Enable / No warning	-4999–4999 *0.000	6-8* LCP Potentiometer	[0] Disable
[5] Drive running	5-58 Term. 33 High Ref./Feedb. Value	6-80 LCP Potmeter Enable	*[1] Enable
[6] Running / No warning	-4999–4999 *50.000	[0] Disabled	7-32 Process PI Start Speed
[7] Run in range / No warning	6-** Analog In/Out	*[1] Enable	0.0–200.0 Hz *0.0 Hz
[8] Run on ref / No warning	6-0* Analog I/O Mode	6-81 LCP potm. Low Reference	7-33 Process PI Proportional Gain
[9] Alarm	6-00 Live Zero Timeout Time	-4999–4999 *0.000	0.00–10.00 *0.01
[10] Alarm or warning	1-99 s *10 s	6-82 LCP potm. High Reference	7-34 Process PI Integral Time
[12] Out of current range	6-01 Live Zero TimeoutFunction	-4999–4999 *50.00	0.10–9999 s *9999 s
[13] Below current, low	*[0] Off	6-9* Analog Output xx	7-38 Process PI Feed Forward Factor
[14] Above current, high	[1] Freeze output	6-90 Terminal 42 Mode	0–400% *0%
[16] Below frequency, low	[2] Stop	*[0] 0-20 mA	7-39 On Reference Bandwidth
[17] Above frequency, high	[3] Jogging	[1] 4-20 mA	0–200% *5%
[19] Below feedback, low	[4] Max speed	[2] Digital Output	8-** omm. and Options
[20] Above feedback, high	[5] Stop and trip	6-91 Terminal 42 Analog Output	8-0* General Settings
[21] Thermal warning	6-1* Analog Input 1	*[0] No operation	8-01 Control Site
[22] Ready, No thermal warning	6-10 Terminal 53 Low Voltage	[10] Output Frequency	*[0] Digital and ControlWord
[23] Remote ready, No thermal warning	0.00–9.99 V *0.07 V	[11] Reference	[1] Digital only
[24] Ready, Voltage ok	6-11 Terminal 53 High Voltage	[12] Feedback	[2] ControlWord only
[25] Reverse	0.01–10.00 V *10.00 V	[13] Motor Current	8-02 Control Word Source
[26] Bus ok	6-12 Terminal 53 Low Current	[16] Power	[0] None
[28] Brake, NoWarn	0.00–19.99 mA *0.14 mA	[19] DC Link Voltage	*[1] FC RS485
[29] Brake ready/NoFault	6-13 Terminal 53 High Current	[20] Bus Reference	8-03 Control Word Timeout Time
[30] BrakeFault (IGBT)	0.01–20.00 mA *20.00 mA	6-92 Terminal 42 Digital Output	0.1–6500 s *1.0 s
[32] Mech.brake control	6-14 Term. 53 Low Ref./Feedb. Value	See parameter 5-40	8-04 Control Word Timeout Function
[36] Control word bit 11	-4999–4999 *0.000	*[0] No Operation	*[0] Off
[41] Below reference, low	6-15 Term. 53 High Ref./Feedb. Value	[80] SL Digital Output A	[1] Freeze Output
[42] Above reference, high	-4999–4999 *50.000	6-93 Terminal 42 Output Min Scale	[2] Stop
[51] Local ref. active	6-16 Terminal 53 Filter Time Constant	0.00–200.0% *0.00%	[3] Jogging
[52] Remote ref. active	0.01–10.00 s *0.01 s	6-94 Terminal 42 Output Max Scale	[4] Max. Speed
[53] No alarm	6-19 Terminal 53 mode	0.00–200.0% *100.0%	[5] Stop and trip
[54] Start cmd active	*[0] Voltage mode	7-** Controllers	8-06 Reset Control Word Timeout
[55] Running reverse	[1] Current mode 4	7-2* Process Ctrl. Feedb	*[0] No Function
[56] Drive in hand mode	6-2* Analog Input 2	7-20 Process CL Feedback 1 Resource	[1] Do reset
[57] Drive in auto mode	6-22 Terminal 60 Low Current	*[0] NoFunction	8-3* FC Port Settings
[60-63] Comparator 0-3	0.00–19.99 mA *0.14 mA	[1] Analog Input 53	8-30 Protocol
[70-73] Logic rule 0-3	6-23 Terminal 60 High Current	[2] Analog input 60	*[0] FC
[81] SL digital output B	0.01–20.00 mA *20.00 mA	[8] PulseInput33	[2] Modbus
5-41 On Delay, Relay	6-24 Term. 60 Low Ref./Feedb. Value	[11] LocalBusRef	8-31 Address
0.00–600.00 s *0.01 s	-4999–4999 *0.000	7-3* Process PI Ctrl.	1-247 *1
5-42 Off Delay, Relay	6-25 Term. 60 High Ref./Feedb. Value	7-30 Process PI Normal/ Inverse Ctrl	8-32 FC Port Baud Rate
0.00–600.00 s *0.01 s	-4999–4999 *50.00	*[0] Normal	[0] 2400 Baud
5-5* Pulse Input	6-26 Terminal 60 Filter Time Constant	[1] Inverse	[1] 4800 Baud
5-55 Terminal 33 Low Frequency			*[2] 9600 Baud For choose FC Bus in 8-30
20–4999 Hz *20 Hz			*[3] 19200 Baud For choose Modbus in 8-30
5-56 Terminal 33 High Frequency			
21–5000 Hz *5000 Hz			

Table 9: Parameter List

<p>[4] 38400 Baud 8-33 FC Port Parity *[0] Even Parity, 1 Stop Bit [1] Odd Parity, 1 Stop Bit [2] No Parity, 1 Stop Bit [3] No Parity, 2 Stop Bits 8-35 Minimum Response Delay 0.001–0.5 *0.010 s 8-36 Max Response Delay 0.100–10.00 s *5.000 s 8-4* FC MC protocol set 8-43 FC Port PCD Read Configuration *[0] None Expressionlimit [1] [1500] Operation Hours [2] [1501] Running Hours [3] [1502] kWh Counter [4] [1600] Control Word [5] [1601] Reference [Unit] [6] [1602] Reference % [7] [1603] Status Word [8] [1605] Main Actual Value [%] [9] [1609] Custom Readout [10] [1610] Power [kW] [11] [1611] Power [hp] [12] [1612] Motor Voltage [13] [1613] Frequency [14] [1614] Motor Current [15] [1615] Frequency [%] [16] [1618] Motor Thermal [17] [1630] DC Link Voltage [18] [1634] Heatsink Temp. [19] [1635] Inverter Thermal [20] [1638] SL Controller State [21] [1650] External Reference [22] [1651] Pulse Reference [23] [1652] Feedback [Unit] [24] [1660] Digital Input 18,19,27,33 [25] [1661] Digital Input 29 [26] [1662] Analog Input 53 (V) [27] [1663] Analog Input 53 (mA) [28] [1664] Analog Input 60 [29] [1665] Analog Output 42 [mA] [30] [1668] Freq. Input 33 [Hz] [31] [1671] Relay Output [bin] [32] [1672] Counter A</p>	<p>[33] [1673] Counter B [34] [1690] Alarm Word [35] [1692] Warning Word [36] [1694] Ext. Status Word 8-5* Digital/Bus 8-50 Coasting Select [0] DigitalInput [1] Bus [2] LogicAnd *[3] LogicOr 8-51 Quick Stop Select See par. 8-50 * [3] LogicOr 8-52 DC Brake Select See par. 8-50 *[3] LogicOr 8-53 Start Select See par. 8-50 *[3] LogicOr 8-54 Reversing Select See par. 8-50 *[3] LogicOr 8-55 Set-up Select See par. 8-50 *[3] LogicOr 8-56 Preset Reference Select See parameter 8-50 * [3] LogicOr 8-8* Bus communication Diagnostics 8-80 Bus Message Count 0-0 N/A *0 N/A 8-81 Bus Error Count 0-0 N/A *0 N/A 8-82 Slave Messages Rcvd 0-0 N/A *0 N/A 8-83 Slave Error Count 0-0 N/A *0 N/A 8-9* Bus Jog / Feedback 8-94 Bus feedback 1 0x8000-0x7FFF *0 13-** Smart Logic 13-0* SLC Settings 13-00 SL Controller Mode *[0] Off [1] On 13-01 Start Event [0] False [1] True [2] Running [3] InRange [4] OnReference [7] OutOfCurrentRange [8] BelowLow [9] AboveHigh [16] ThermalWarning</p>	<p>[17] MainOutOfRange [18] Reversing [19] Warning [20] Alarm_Trip [21] Alarm_TripLock [22-25] Comparator 0-3 [26-29] LogicRule0-3 [33] DigitalInput_18 [34] DigitalInput_19 [35] DigitalInput_27 [36] DigitalInput_29 [38] DigitalInput_33 *[39] StartCommand [40] DriveStopped 13-02 Stop Event See parameter 13-01 * [40] DriveStopped 13-03 Reset SLC *[0] Do not reset [1] Reset SLC 13-1* Comparators 13-10 Comparator Operand *[0] Disabled [1] Reference [2] Feedback [3] MotorSpeed [4] MotorCurrent [6] MotorPower [7] MotorVoltage [8] DCLinkVoltage [12] AnalogInput53 [13] AnalogInput60 [18] PulseInput33 [20] AlarmNumber [30] CounterA [31] CounterB 13-11 Comparator Operator [0] Less Than *[1] Approximately equals [2] Greater Than 13-12 Comparator Value -9999–9999 *0.0 13-2* Timers 13-20 SL Controller Timer 0.0–3600 s *0.0 s 13-4* Logic Rules 13-40 Logic Rule Boolean 1 See par. 13-01 *[0] False [30] - [32] SL Time-out 0-2 13-41 Logic Rule Operator 1</p>	<p>*[0] Disabled [1] And [2] Or [3] And not [4] Or not [5] Not and [6] Not or [7] Not and not [8] Not or not 13-42 Logic Rule Boolean 2 See par. 13-40 * [0] False 13-43 Logic Rule Operator 2 See par. 13-41 *[0] Disabled 13-44 Logic Rule Boolean 3 See par. 13-40 * [0] False 13-5* States 13-51 SL Controller Event See par. 13-40 *[0] False 13-52 SL Controller Action *[0] Disabled [1] NoAction [2] SelectSetup1 [3] SelectSetup2 [10-17] SelectPresetRef0-7 [18] SelectRamp1 [19] SelectRamp2 [22] Run [23] RunReverse [24] Stop [25] Qstop [26] DCstop [27] Coast [28] FreezeOutput [29] Start-Timer0 [30] StartTimer1 [31] StartTimer2 [32] Set Digital Output A Low [33] Set Digital Output B Low [38] Set Digital Output A High [39] Set Digital Output B High [60] ResetCounterA [61] ResetCounterB 14-** Special Functions 14-0* Inverter Switching 14-01 Switching Frequency [0] 2 kHz *[1] 4 kHz [2] 8 kHz [4] 16 kHz not available for M5 14-03 Overmodulation [0] Off</p>
--	---	--	---

Table 10: Parameter List

[1] On	15-4 Drive Identification	16-62 Analog Input 53 (volt)	
14-1* Mains monitoring	15-40 FC Type	16-63 Analog Input 53 (current)	
14-12 Function at mains imbalance	15-41 Power Section	16-64 Analog Input 60	
*[0] Trip	15-42 Voltage	16-65 Analog Output 42 [mA]	
[1] Warning	15-43 Software Version	16-68 Pulse Input [Hz]	
[2] Disabled	15-46 Frequency Converter Order. No	16-71 Relay Output [bin]	
14-2* Trip Reset	15-48 LCP Id No	16-72 Counter A	
14-20 Reset Mode	15-51 Frequency Converter Serial No	16-73 Counter B	
*[0] Manual reset	16-** Data Readouts	16-8* Fieldbus/FC Port	
[1-9] AutoReset 1-9	16-0* General Status	16-86 FC Port REF 1	
[10] AutoReset 10	16-00 Control Word	0x8000-0x7FFFF	
[11] AutoReset 15	0-0XFFFF	16-9* Diagnosis Readouts	
[12] AutoReset 20	16-01 Reference [Unit]	16-90 Alarm Word	
[13] Infinite auto reset	-4999-4999 *0.000	0-0XFFFFFFFF	
[14] Reset at power up	16-02 Reference %	16-92 Warning Word	
14-21 Automatic Restart Time	-200.0-200.0% *0.0%	0-0XFFFFFFFF 16-94 Ext. Status Word	
0-600s * 10s	16-03 Status Word	0-0XFFFFFFFF	
14-22 Operation Mode	0-0XFFFF	18-** Extended Motor Data	
[0] Normal Operation	16-05 Main Actual Value [%]	18-8 Motor Resistors	
[2] Initialisation	-200.0-200.0% *0.0%	18-80 Stator Resistance (High resolution)	
14-26 Action At Inverter Fault	16-09 Custom Readout	0.000-99.990 ohm *0.000 ohm	
*[0] Trip	Dep. on par. 0-31, 0-32	18-81 Stator Leakage Reactance(High resolution)	
[1] Warning	16-1* Motor Status	0.000-99.990 ohm *0.000 ohm	
14-4* Energy Optimising	16-10 Power [kW]		
14-41 AEO Minimum Magnetisation	16-11 Power [hp]		
40-75 %*66 %	16-12 Motor Voltage [V]		
14-9* Fault Settings	16-13 Frequency [Hz]		
14-90 Fault level	16-14 Motor Current [A]		
[3] Trip Lock	16-15 Frequency [%]		
[4] Trip with delayed reset	16-18 Motor Thermal [%]		
15-** Drive Information	16-3* Drive Status		
15-0* Operating Data	16-30 DC Link Voltage		
15-00 Operating Days	16-34 Heat sink Temp.		
15-01 Running Hours	16-35 Inverter Thermal		
15-02 kWh Counter	16-36 Inv.Nom. Current		
15-03 Power Ups	16-37 Inv. Max. Current		
15-04 Over Temps	16-38 SL Controller State		
15-05 Over Volts	16-5* Ref./Feedb.		
15-06 Reset kWh Counter	16-50 External Reference		
*[0] Do not reset	16-51 Pulse Reference		
[1] Reset counter	16-52 Feedback [Unit]		
15-07 Reset Running Hours Counter	16-6* Inputs/Outputs		
*[0] Do not reset	16-60 Digital Input		
[1] Reset counter	18,19,27,33		
15-3* Fault Log	0-1111		
15-30 Fault Log: Error Code	16-61 Digital Input 29		
	0-1		

6 Troubleshooting

6.1 Warnings and Alarms

Table 11: Warnings and Alarms

Number	Description	Warn- ing	Alarm	Trip lock	Er- ror	Cause of problem
2	Live zero error	X	X			Signal on terminal 53 or 54 is less than 50% of the value set in: <ul style="list-style-type: none"> • <i>Parameter 6-10 Terminal 53 Low Voltage.</i> • <i>Parameter 6-12 Terminal 53 Low Current.</i> • <i>Parameter 6-22 Terminal 54 Low Current.</i>
4	Mains phase loss ⁽¹⁾	X	X	X		Missing phase on the supply side or too high voltage imbalance. Check the supply voltage.
7	DC overvoltage ⁽¹⁾	X	X			DC-link voltage exceeds the limit.
8	DC undervoltage ⁽¹⁾	X	X			DC-link voltage drops below voltage warning low-limit.
9	Inverter overload	X	X			More than 100% load for a long time.
10	Motor ETR overtemperature	X	X			Motor is too hot due to more than 100% load for a long time.
11	Motor thermistor overtemperature	X	X			Thermistor or thermistor connection is disconnected.
12	Torque limit	X				Torque exceeds value set in either <i>parameter 4-16 Torque Limit Motor Mode</i> or <i>parameter 4-17 Torque Limit Generator Mode</i> .
13	Overcurrent	X	X	X		Inverter peak current limit is exceeded.
14	Ground fault	X	X	X		Discharge from output phases to ground.
16	Short circuit		X	X		Short circuit in motor or on motor terminals.
17	Control word timeout	X	X			No communication to drive.
25	Brake resistor short-circuited		X	X		Brake resistor is short-circuited, thus the brake function is disconnected.
27	Brake chopper short-circuited		X	X		Brake transistor is short-circuited, thus the brake function is disconnected.
28	Brake check		X			Brake resistor is not connected/working.
29	Power board over temp	X	X	X		Heat sink cutout temperature has been reached.
30	Motor phase U missing		X	X		Motor phase U is missing. Check the phase.
31	Motor phase V missing		X	X		Motor phase V is missing. Check the phase.
32	Motor phase W missing		X	X		Motor phase W is missing. Check the phase.
38	Internal fault		X	X		Contact the local Danfoss supplier.
44	Ground fault		X	X		Discharge from output phases to ground.
47	Control voltage fault		X	X		24 V DC supply is overloaded.

Number	Description	Warn- ing	Alarm	Trip lock	Er- ror	Cause of problem
51	AMA check U_{nom} and I_{nom}		X			Wrong setting for motor voltage and/or motor current.
52	AMA low I_{nom}		X			The motor current is too low. Check the settings.
59	Current limit	X				The drive overload.
63	Mechanical brake low		X			Actual motor current has not exceeded the release brake current within the start delay time window.
80	Drive initialized to de- fault value		X			All parameter settings are initialized to default settings.
84	The connection be- tween drive and LCP is lost				X	No communication between LCP and drive.
85	Key disabled				X	See <i>parameter group 0-4* LCP</i> .
86	Copy fail				X	An error occurred while copying from drive to LCP, or from LCP to drive.
87	LCP data invalid				X	Occurs when copying from LCP if the LCP contains er- roneous data - or if no data was uploaded to the LCP.
88	LCP data not compati- ble				X	Occurs when copying from LCP if data are moved be- tween drives with major differences in software ver- sions.
89	Parameter read only				X	Occurs when trying to write to a read-only parameter.
90	Parameter database busy				X	LCP and RS485 connection are trying to update param- eters simultaneously.
91	Parameter value is not valid in this mode				X	Occurs when trying to write an illegal value to a param- eter.
92	Parameter value ex- ceeds the minimum/ maximum limits				X	Occurs when trying to set a value outside the range.
nw run	Not while running				X	Parameters can only be changed when the motor is stopped.
Err.	A wrong password was entered				X	Occurs when using a wrong password for changing a password-protected parameter.

¹ These faults are caused by mains distortions. Install a Danfoss line filter to rectify this problem.

7 Specifications

7.1 Mains Supply 1x200–240 V AC

Table 12: Mains Supply 1x200–240 V AC

Normal overload 150% for 1 minute					
Drive	PK18	PK37	PK75	P1K5	P2K2
Typical shaft output [kW]	0.18	0.37	0.75	1.5	2.2
Typical shaft output [hp]	0.25	0.5	1	2	3
Enclosure protection rating IP20	M1	M1	M1	M2	M3
Output current					
Continuous (3x200–240 V AC) [A]	1.2	2.2	4.2	6.8	9.6
Intermittent (3x200–240 V AC) [A]	1.8	3.3	6.3	10.2	14.4
Maximum cable size					
(Mains, motor) [mm ² /AWG]	4/10				
Maximum input current					
Continuous (1x200–240 V) [A]	3.3	6.1	11.6	18.7	26.4
Intermittent (1x200–240 V) [A]	4.5	8.3	15.6	26.4	37
Maximum mains fuses [A]	See <i>chapter Fuses</i> .				
Environment					
Estimated power loss [W], Best case/typical ⁽¹⁾	12.5/ 15.5	20/ 25	36.5/ 44	61/ 67	81/ 85.1
Weight enclosure IP20 [kg]	1.0	1.0	1.0	1.5	2.8
Efficiency [%], Best case/typical ⁽²⁾	95.6/ 94.5	96.5/ 95.6	96.6/ 96	97/ 96.7	96.9/ 97.1

¹ Applies for dimensioning of drive cooling. If the switching frequency is higher than the default setting, the power losses may increase. LCP and typical control card power consumptions are included. For power loss data according to EN 50598-2, refer to Danfoss [MyDrive® ecoSmart™](#) website.

² Efficiency measured at nominal current. For energy efficiency class, see chapter Surroundings. For part load losses, see Danfoss [MyDrive® ecoSmart™](#) website.

7.2 Mains Supply 3x380–480 V AC

Table 13: Mains Supply 3x380–480 V AC

Normal overload 150% for 1 minute						
Drive	PK37	PK75	P1K5	P2K2	P3K0	P4K0
Typical shaft output [kW]	0.37	0.75	1.5	2.2	3.0	4.0
Typical shaft output [hp]	0.5	1	2	3	4	5.5
Enclosure protection rating IP20	M1	M1	M1/M2	M2	M3	M3
Output current						

Continuous (3x380–440 V) [A]	1.2	2.2	3.7	5.3	7.2	9.0
Intermittent (3x380–440 V) [A]	1.8	3.3	5.6	8.0	10.8	13.7
Continuous (3x440–480 V) [A]	1.1	2.1	3.4	4.8	6.3	8.2
Intermittent (3x440–480 V) [A]	1.7	3.2	5.1	7.2	9.5	12.3
Maximum cable size						
(Mains, motor) [mm ² /AWG]	4/10					
Maximum input current						
Continuous (3x380–440 V) [A]	1.9	3.5	5.9	8.5	11.5	14.4
Intermittent (3x380–440 V) [A]	2.6	4.7	8.7	12.6	16.8	20.2
Continuous (3x440–480 V) [A]	1.7	3.0	5.1	7.3	9.9	12.4
Intermittent (3x440–480 V) [A]	2.3	4.0	7.5	10.8	14.4	17.5
Maximum mains fuses [A]	See <i>chapter Fuses</i> .					
Environment						
Estimated power loss [W], Best case/typical ⁽¹⁾	18.5/ 25.5	28.5/ 43.5	41.5/ 56.5	57.5/ 81.5	75/ 101.6	98.5/ 133.5
Weight enclosure IP20 [kg]	1.0	1.0	1.0/1.5	1.5	2.8	2.8
Efficiency [%], Best case/typical ⁽²⁾	96.8/ 95.5	97.4/ 96	98/ 97.2	97.9/ 97.1	98/ 97.2	98/ 97.3

¹ Applies for dimensioning of drive cooling. If the switching frequency is higher than the default setting, the power losses may increase. LCP and typical control card power consumptions are included. For power loss data according to EN 50598-2, refer to Danfoss [MyDrive® ecoSmart™](#) website.

² Efficiency measured at nominal current. For energy efficiency class, see chapter Surroundings. For part load losses, see Danfoss [MyDrive® ecoS-mart™](#) website.

Table 14: Mains Supply 3x380–480 V AC

Normal overload 150% for 1 minute						
Drive	P5K5	P7K5	P11K	P15K	P18K	P22K
Typical shaft output [kW]	5.5	7.5	11	15	18.5	22
Typical shaft output [hp]	7.5	10	15	20	25	30
Enclosure protection rating IP20	M3	M3	M4	M4	M5	M5
Output current						
Continuous (3x380–440 V) [A]	12	15.5	23	31	37	43
Intermittent (3x380–440 V) [A]	18	23.5	34.5	46.5	55.5	64.5
Continuous (3x440–480 V) [A]	11	14	21	27	34	40
Intermittent (3x440–480 V) [A]	16.5	21.3	31.5	40.5	51	60
Maximum cable size						
(Mains, motor) [mm ² /AWG]	4/10		16/6			

Maximum input current						
Continuous (3x380–440 V) [A]	19.2	24.8	33	42	34.7	41.2
Intermittent (3x380–440 V) [A]	27.4	36.3	47.5	60	49	57.6
Continuous (3x440–480 V) [A]	16.6	21.4	29	36	31.5	37.5
Intermittent (3x440–480 V) [A]	23.6	30.1	41	52	44	53
Maximum mains fuses [A]	See <i>chapter Fuses</i> .					
Environment						
Estimated power loss [W], Best case/typical ⁽¹⁾	131/ 166.8	175/ 217.5	290/ 342	387/ 454	395/ 428	467/ 520
Weight enclosure IP20 [kg]	2.8	2.8	–	–	–	–
Efficiency [%], Best case/typical ⁽²⁾	98/ 97.5	98/ 97.5	97.8/ 97.4	97.7/ 97.4	98.1/ 98	98.1/ 97.9

¹ Applies for dimensioning of drive cooling. If the switching frequency is higher than the default setting, the power losses may increase. LCP and typical control card power consumptions are included. For power loss data according to EN 50598-2, refer to Danfoss [MyDrive® ecoSmart™](#) website.

² Efficiency measured at nominal current. For energy efficiency class, see chapter Surroundings. For part load losses, see Danfoss [MyDrive® ecoSmart™](#) website.

8 General Technical Data

8.1 Protection and Features

- Electronic motor thermal protection against overload.
- Temperature monitoring of the heat sink ensures that the drive trips if there is overtemperature.
- The drive is protected against short circuits between motor terminals U, V, W.
- When a motor phase is missing, the drive trips and issues an alarm.
- When a mains phase is missing, the drive trips or issues a warning (depending on the load).
- Monitoring of the DC-link voltage ensures that the drive trips when the DC-link voltage is too low or too high.
- The drive is protected against ground faults on motor terminals U, V, W.

8.2 Mains Supply (L1/L, L2, L3/N)

Mains supply (L1/L, L2, L3/N)

Supply voltage	200–240 V ±10%
Supply voltage	380–480 V ±10%
Supply frequency	50/60 Hz
Maximum imbalance temporary between mains phases	3.0% of rated supply voltage
True power factor	≥0.4 nominal at rated load
Displacement power factor (cosφ) near unity	(>0.98)
Switching on input supply L1/L, L2, L3/N (power-ups)	Maximum 2 times/minute
Environment according to EN60664-1	Overvoltage category III/pollution degree 2

The unit is suitable for use on a circuit capable of delivering not more than 100000 RMS symmetrical Amperes, 240/480 V maximum.

8.3 Motor Output (U, V, W)

Output voltage	0–100% of supply voltage
Output frequency	0–200 Hz (VVC ⁺), 0–400 Hz (u/f)
Switching on output	Unlimited
Ramp times	0.05–3600 s

8.4 Cable Length and Cross-section

Maximum motor cable length, shielded/armored (EMC-correct installation)	15 m (49 ft)
Maximum motor cable length, unshielded/unarmored	50 m (164 ft)
Maximum cross-section to motor, mains	See <i>chapter Specifications</i> for more information.
Connection to load sharing/brake (M1, M2, M3)	6.3 mm insulated Faston plugs
Maximum cross-section to load sharing/brake (M4, M5)	16 mm ² /6 AWG
Maximum cross-section to control terminals, rigid wire	1.5 mm ² /16 AWG (2x0.75 mm ²)
Maximum cross-section to control terminals, flexible cable	1 mm ² /18 AWG
Maximum cross-section to control terminals, cable with enclosed core	0.5 mm ² /20 AWG
Minimum cross-section to control terminals	0.25 mm ² /24 AWG

8.5 Digital Inputs (Pulse/encoder Inputs)

Programmable digital inputs (pulse/encoder)	5 (1)
Terminal number	18, 19, 27, 29, 33
Logic	PNP or NPN
Voltage level	0–24 V DC

Voltage level, logic 0 PNP	<5 V DC
Voltage level, logic 1 PNP	>10 V DC
Voltage level, logic 0 NPN	>19 V DC
Voltage level, logic 1 NPN	<14 V DC
Maximum voltage on input	28 V DC
Input resistance, R_i	Approximately 4000 Ω
Maximum pulse frequency at terminal 33	5000 Hz
Minimum pulse frequency at terminal 33	20 Hz

8.6 Analog Inputs

Number of analog inputs	2
Terminal number	53, 60
Voltage mode (terminal 53)	Switch S200=OFF(U)
Current mode (terminal 53 and 60)	Switch S200=ON(I)
Voltage level	0–10 V
Input resistance, R_i	Approximately 10000 Ω
Maximum voltage	20 V
Current level	0/4–20 mA (scalable)
Input resistance, R_i	Approximately 200 Ω
Maximum current	30 mA

8.7 Analog Outputs

Number of programmable analog outputs	1
Terminal number	42
Current range at analog output	0/4–20 mA
Maximum load to common at analog output	500 Ω
Maximum voltage at analog output	17 V
Accuracy on analog output	Maximum error: 0.8% of full scale
Scan interval	4 ms
Resolution on analog output	8 bit

8.8 Control Card, RS485 Serial Communication

Terminal number	68 (P, TX+, RX+), 69 (N, TX-, RX-)
Terminal number	61 common for terminals 68 and 69

8.9 Control Card, 24 V DC Output

Terminal number	12
Maximum load (M1 and M2)	100 mA
Maximum load (M3)	50 mA
Maximum load (M4 and M5)	80 mA

8.10 Relay Output

Programmable relay output	1
Relay 01 terminal number	01–03 (break), 01–02 (make)
Maximum terminal load (AC-1) ⁽¹⁾ on 01–02 (NO) (Resistive load)	250 V AC, 2 A
Maximum terminal load (AC-15) ⁽¹⁾ on 01–02 (NO) (Inductive load @ $\cos\phi$ 0.4)	250 V AC, 0.2 A

Maximum terminal load (DC-1) ⁽¹⁾ on 01–02 (NO) (Resistive load)	30 V DC, 2 A
Maximum terminal load (DC-13) ⁽¹⁾ on 01–02 (NO) (Inductive load)	24 V DC, 0.1 A
Maximum terminal load (AC-1) ⁽¹⁾ on 01–03 (NC) (Resistive load)	250 V AC, 2 A
Maximum terminal load (AC-15) ⁽¹⁾ on 01–03 (NC) (Inductive load @ cosφ 0.4)	250 V AC, 0.2 A
Maximum terminal load (DC-1) ⁽¹⁾ on 01–03 (NC) (Resistive load)	30 V DC, 2 A
Minimum terminal load on 01–03 (NC), 01–02 (NO)	24 V DC 10 mA, 24 V AC 20 mA
Environment according to EN 60664-1	Overvoltage category III/pollution degree 2

¹ IEC 60947 part 4 and 5.

8.11 Control Card, +10 V DC Output

Terminal number	50
Output voltage	10.5 V ±0.5 V
Maximum load	25 mA

NOTICE

All inputs, outputs, circuits, DC supplies, and relay contacts are galvanically isolated from the supply voltage (PELV) and other high-voltage terminals.

8.12 Surroundings

Enclosure protection rating	IP20
Enclosure kit available	IP21, TYPE 1
Vibration test	1.0 g
Maximum relative humidity	5–95% (IEC 60721-3-3; Class 3K3 (non-condensing) during operation)
Aggressive environment (IEC 60721-3-3), coated	Class 3C3
Test method according to IEC 60068-2-43 H2S (10 days)	
Ambient temperature ⁽¹⁾	Maximum 40 °C (104 °F)
Minimum ambient temperature during full-scale operation	0 °C (32 °F)
Minimum ambient temperature at reduced performance	-10 °C (14 °F)
Temperature during storage/transport	-25 to +65/70 °C (-13 to +149/158 °F)
Maximum altitude above sea level without derating ⁽¹⁾	1000 m (3280 ft)
Maximum altitude above sea level with derating ⁽¹⁾	3000 m (9842 ft)
Safety standards	EN/IEC 61800-5-1
Energy efficiency class ⁽²⁾	IE2

¹ Refer to *chapter Special Conditions* for:

- Derating for high ambient temperature.
- Derating for high altitude.

² Determined according to EN 50598-2 at:

- Rated load.
- 90% rated frequency.
- Switching frequency factory setting.
- Switching pattern factory setting.

9 Special Conditions

9.1 Derating for Ambient Temperature

The ambient temperature measured over 24 hours should be at least 5 °C (9 °F) lower than the maximum ambient temperature.

If the drive is operated at high ambient temperature, decrease the continuous output current.

The drive has been designed for operation at maximum 50 °C (122 °F) ambient temperature with 1 motor size smaller than nominal. Continuous operation at full load at 50 °C (122 °F) ambient temperature reduces the lifetime of the drive.

9.2 Derating for Low Air Pressure

The cooling capability of air is decreased at low air pressure.

⚠ CAUTION ⚠

INSTALLATION AT HIGH ALTITUDE

For altitudes above 2000 m (6560 ft), contact Danfoss regarding PELV.

Below 1000 m (3280 ft) altitude, no derating is necessary, but above 1000 m (3280 ft), decrease the ambient temperature or the maximum output current.

Decrease the output by 1% per 100 m (328 ft) altitude above 1000 m (3280 ft), or reduce the maximum ambient temperature by 1 °C (1.8 °F) per 200 m (656 ft).

9.3 Derating for Running at Low Speeds

When a motor is connected to a drive, check that the cooling of the motor is adequate.

A problem may occur at low speeds in constant torque applications. Running continuously at low speeds – less than half the nominal motor speed – may require extra air cooling. Alternatively, select a larger motor (1 size up).

10 Options and Spare Parts

10.1 Options and Spare Parts

Table 15: Options and Spare Parts

Ordering number	Description
132B0100	VLT® Control Panel LCP 11 w/o potentiometer
132B0101	VLT® Control Panel LCP 12 with potentiometer
132B0102	LCP Remote Mounting Kit , w/3 m (10 ft) cable, IP55 with LCP 11, IP21 with LCP 12
132B0106	Decoupling plate mounting kit, M1 and M2
132B0107	Decoupling plate mounting kit, M3
132B0108	IP20 to IP21/Type1 conversion kit, M1
132B0109	IP20 to IP21/Type1 conversion kit, M2
132B0110	IP20 to IP21/Type1 conversion kit, M3
132B0111	DIN rail mounting kit, M1/M2
132B0122	Decoupling plate mounting kit, M4, M5
132B0126	Enclosure size M1 spare parts kits
132B0127	Enclosure size M2 spare parts kits
132B0128	Enclosure size M3 spare parts kits
132B0129	Enclosure size M4 spare parts kits
132B0130	Enclosure size M5 spare parts kits
132B0131	Blank cover
130B2522	VLT® Line Filter MCC 107 for 136N8920
130B2522	VLT® Line Filter MCC 107 for 136N8921
130B2533	VLT® Line Filter MCC 107 for 136N8923
130B2525	VLT® Line Filter MCC 107 for 136N8924
130B2530	VLT® Line Filter MCC 107 for 136N8925
130B2523	VLT® Line Filter MCC 107 for 136N8926
130B2523	VLT® Line Filter MCC 107 for 136N8927
130B2524	VLT® Line Filter MCC 107 for 136N8928/136U9617
130B2526	VLT® Line Filter MCC 107 for 136N8929
130B2529	VLT® Line Filter MCC 107 for 136N8930
130B2531	VLT® Line Filter MCC 107 for 136N8931
130B2528	VLT® Line Filter MCC 107 for 136N8934
130B2527	VLT® Line Filter MCC 107 for 136N8935

Danfoss line filters and brake resistors are available upon request.

Index

+	Mains supply 1x200–240 V AC.....	26
+10 V DC output.....	Mains supply 3x380–480 V AC.....	26, 27
	Mechanical dimensions.....	9
2	Motor output (U, V, W).....	29
24 V DC output.....	Motor overload protection.....	29
	Motor thermal protection.....	7
A	N	
Additional resources.....	Navigation keys.....	17
Ambient temperature.....	Non-UL compliance.....	10
Analog input.....		
	O	
B	Operation keys.....	18
Brake.....	Options and Spare Parts.....	33
Branch circuit protection.....	Overcurrent protection.....	10
C	P	
Cable length and cross-section.....	Power circuit.....	15
Control card.....	Protection.....	29
	Purpose of the manual.....	5
D		
Derating for ambient temperature.....	Q	
Derating for low air pressure.....	Qualified personnel.....	5, 6
Derating for running at low speed.....	Quick Menu.....	17
Digital input.....		
Discharge time.....	R	
	Relay output.....	30
E	Residual current devices.....	7
Energy efficiency.....	RS485 serial communication.....	30
Energy efficiency class.....		
	S	
F	Short-circuit protection.....	10
Fuse.....	Side-by-side installation.....	9
	Status.....	17
I	Surroundings.....	31
Installation	Switches	
Qualified personnel.....	Disconnect.....	
IT mains.....	Symbols.....	6
L	U	
Leakage current.....	Unintended start.....	
Load sharing.....		
	V	
M	Voltage	
Main Menu.....	Safety warning.....	
Mains supply (L1/L, L2, L3/N).....	Voltage level.....	29

ENGINEERING
TOMORROW



Danfoss A/S
Ulsnaes 1
DK-6300 Graasten
vlt-drives.danfoss.com

Danfoss can accept no responsibility for possible errors in catalogs, brochures and other printed material. Danfoss reserves the right to alter its products without notice. This also applies to products already on order provided that such alterations can be made without subsequential changes being necessary in specifications already agreed. All trademarks in this material are property of the respective companies. Danfoss and the Danfoss logotype are trademarks of Danfoss A/S. All rights reserved.

