

# UniOP

**Universal Operator Panels**

Installation Guide



UniOP™  
Universal Operator Panel  
Installation Guide  
Document code MANUUNIOP22  
Version 1.09  
Date 03.02.2012

The contents of this manual have been checked for correctness and conformance to the described equipment, Nevertheless it is not possible to guarantee the absence of possible discrepancies. The contents of the manual are checked on a regular basis and any necessary corrections are introduced in successive versions.

Information in this document is subject to change without notice.

No part of this manual may be reproduced or transmitted in any form or by any means, electronic or mechanical, for any purpose, without the prior written permission of Exor International S.p.A

Windows is a registered trademark of Microsoft Corporation.

Copyright © 2001-2012 Exor International S.p.A. All rights reserved.

Exor International S.p.A. - San Giovanni Lupatoto VR, Italy.

# Installation Guide

## Contents

- Introduction..... 1
  - Product Identification ..... 2
- Technical Specifications ..... 3
- Installation..... 12
  - Physical Dimensions..... 12
  - Connections ..... 30
  - Power Supply and Grounding..... 39
  - PLC Port ..... 40
  - PC/Printer Port..... 41
  - AUX Port..... 43
  - Ethernet Port ..... 45
  - Models without the PC/Printer Port ..... 45
  - External Keyboard Port ..... 45
  - Battery Replacement..... 46
  - Removing the Legends..... 47
  - Dedicated LED's..... 48
  - Usage and Safety Guidelines ..... 49
  - Installation Environment..... 49
  - Installation Procedures..... 52
- Handling the Memory Cards ..... 53
- Getting Started ..... 54
  - Command Summary..... 55
  - Troubleshooting..... 59
  - Touchscreen Calibration ..... 59



---

## Introduction

This Installation Guide describes the main features of the UniOP operator panels. The Guide refers to the following models:

|          |   |
|----------|---|
| BKDC-46  | Operator interface with color display               |
| BKDR-16  | Operator interface with LCD display                 |
| CP01R-04 | Operator interface with LCD display                 |
| CP02R-04 | Operator interface with LCD display                 |
| CP10G-04 | Operator interface with LCD display                 |
| ePAD03   | Low-cost operator interface with LCD display        |
| ePAD04   | Low-cost operator interface with LCD display        |
| ePAD05   | Low-cost operator interface with LCD display        |
| ePAD06   | Low-cost operator interface with LCD display        |
| ePAD33C  | Operator interface with TFT display                 |
| eTOP03   | Operator interface with LCD 3"8 display             |
| eTOP04C  | Operator interface with TFT 4"3 display             |
| eTOP05   | Operator interface with TFT 5"7 display             |
| eTOP05EB | Operator interface with TFT 5"7 display             |
| eTOP06   | Operator interface with TFT 5"7 display             |
| eTOP06C  | Operator interface with TFT 5"7 display             |
| eTOP20C  | Operator interface with TFT 7"5 display             |
| eTOP33C  | Operator interface with TFT 10"4 display            |
| eTOP40C  | Operator interface with TFT 12"1 display            |
| eTOP50C  | Operator interface with XGA TFT 15" display         |
| ETT-VGA  | Operator interface with touch and TFT color display |
| MD02R-04 | Low-cost operator interface with LCD display        |
| MKDG-06  | Operator interface with LCD display                 |
| MKDR-04  | Operator interface with LCD display                 |
| MKDR-05  | Operator interface with LCD display                 |
| MKDR-16  | Operator interface with LCD display                 |

The products have been designed for use in an industrial environment in compliance with the 2004/108/EC EMC Directive.

The products have been designed in compliance with:

EN 61000-6-4                      EN 55011 Class A

EN 61000-6-2                      EN 61000-4-2  
    EN 61000-4-3  
    EN 61000-4-4  
    EN 61000-4-5  
    EN 61000-4-6

The installation of these devices into the residential, commercial and light-industrial environments is allowed only in the case that special in measures are taken in order to ensure conformity to EN 61000-6-3.

The products are in compliance with the Restrictions on Certain Hazardous Substances (RoHS) Directive 2002/95/EC

In compliance with the above regulations the products are CE marked.

**Product Identification**

The product may be identified through a plate attached to the rear cover. You will have to know the type of unit you are using for correct usage of the information contained in the guide.

An example of this plate is shown in the figure below:



|              |                                 |
|--------------|---------------------------------|
| eTOP33C-0050 | product model name              |
| 06/08        | month/year of production        |
| 13435 35508  | serial number                   |
| H/W V        | hardware version of the product |
| S/W V        | software version of the product |

## Technical Specifications

|                      |  |
|----------------------|--|
| Power supply voltage | DC 18 - 30 V   |
| Power consumption    | (1)  |
| Back-up battery (1)  | 3 V 270mA Lithium, not rechargeable, life about 1 year, user replaceable, model: CR2430. Change with same battery or equivalent with the work temperature of UniOP. (for eTOP04C 3V 50mAh Lithium, rechargeable, not user-replaceable, model VL2330) |
| Fuse                 | 2 A T user replaceable (except the models CP10G-04, ePAD03/04/05/06, MKDG-06, ePAD33C and eTOP03/04/05/06/20/33/40/50 that are equipped with an overcurrent protection device)   |

### Environmental conditions

|                                |  |               |
|--------------------------------|--|---------------|
| Operating temperature          | 0 ÷ +50°C, with the exception of EN 60068-2-14 the model indicated on note (2) |               |
| Storage temperature            | -20 ÷ +70°C  | EN 60068-2-14 |
| Operating and storage humidity | 5 ÷ 85 % RH not-condensing   | EN 60068-2-30 |
| Vibrations                     | 5 ÷ 9 Hz, 7mm peak   | EN 60068-2-6  |
|                                | 9 ÷ 150 Hz, 1 G  |               |
| Shock                          | 50 G, 11 ms, 3 pulses per axis   | EN 60068-2-27 |
| Protection class               | IP65 front panel (3)   | EN 60529      |
| Keyboard reliability           | > 3 million operations   |               |
| Touch screen technology        | Resistive  |               |
| Touch screen reliability       | > 1 million operations   |               |

### Electromagnetic Compatibility (EMC)

|  |                                       |              |
|--|---------------------------------------|--------------|
| Emitted interference   | Class A                               | EN 55011     |
| Radiated, radio-frequency, electromagnetic field immunity test | 80 MHz ÷ 1 GHz, 10 V/m                | EN 61000-4-3 |
|  | 1,4GHz ÷ 2 GHz, 3V/m                  |              |
|  | 2GHz ÷ 2,7 GHz, 1V/m                  |              |
| Burst immunity test  | ±2 KV DC power supply                 | EN 61000-4-4 |
|  | ±1 KV signal lines                    |              |
| Surge immunity test  | ±0,5 KV DC power port (line to earth) | EN61000-4-5  |
|  | ±1 KV signal line (line to earth)     |              |

|  |  |              |
|--|--|--------------|
| Electrostatic discharge immunity test                                  | 8 KV (air electrostatic discharge)<br>4KV (contact electrostatic discharge)  | EN 61000-4-2 |
| Immunity to conducted disturbances induced by radiofrequency field     | 0.15 ÷ 80 MHz, 12 V  | EN61000-4-6  |
| Voltage dips, short interruptions and voltage variations immunity test | Port : AC mains; Level :<br>100% duration : 1 cycle and 250 cycles (50Hz) ;<br>40% duration : 10 cycles (50Hz)<br>70% duration : 25 cycles (50Hz)<br>Phase : 0°-180° | EN61000-4-11 |
| PC/Printer Port <sup>(1)</sup>   | RS-232connector D-sub 15 pin female<br>300 - 38400 baud  |              |
| PLC Port   | RS-232, RS-422, RS-485, C.L. 20 mA (active),<br>connector D-15 pin male<br>300 - 38400 <sup>(1)</sup> baud   |              |
| AUX Port   | connector D-9 pin female (functionality can be configured with an optional communication module)   |              |
| User memory  | <sup>(1)</sup>   |              |
| Recipe memory <sup>(1)</sup>   | 16 KB / 32 KB RAM with back-up battery   |              |
| Hardware clock <sup>(1)</sup>  | Clock/Calendar with back-up battery  |              |
| Alarms <sup>(1)</sup>  | 256/1024   |              |
| Historical event list <sup>(1)</sup>                                   | last 256/1024 events with back-up battery  |              |
| Programming software   | Designer version 6   |              |

Notes:

- (1) feature depends on the panel models; see Table 1.
- (2) for models with “B7” suffix range -20 ÷ +60°C  
for eTOP and ePAD range 0 ÷ +45°C
- (3) all the installation instructions listed in the chapter ‘Installation Environment’ must be followed in detail.



| Model   | BKDC-46            | BKDR-16    | CP01R-04   |
|---|--------------------|------------|------------|
| Display   | 16x40 STN<br>color | 16x40 LCD  | 4x20 LCD   |
| Backlight                                       | CCFL               | CCFL       | LED        |
| Graphics  | 320x240            | 320x240    | -          |
| Display dimensions (mm)                         | 121x91             | 121x91     | -          |
| Diagonal (inches)                               | 5.6"               | 5.6"       | -          |
| User memory                                     | 32MB               | 512KB      | 512KB      |
| User memory expansion                           | -                  | up to 1MB  | up to 1MB  |
| Function keys                                   | 33                 | 14         | 5          |
| System keys                                     | 24                 | 23         | 19         |
| Touch screen                                    | -                  | -          | -          |
| User LED's                                      | 24                 | 11         | 5          |
| System LED's                                    | 5                  | 4          | 1          |
| PC/Printer Port                                 | YES                | YES        | YES        |
| PLC Port  | YES                | YES        | YES        |
| AUX Port <sup>(1)</sup>                         | YES                | YES        | YES        |
| DX Port (video input)                           | -                  | -          | -          |
| Ethernet Port                                   | -                  | -          | -          |
| USB Port  | -                  | -          | -          |
| External keyboard Port                          | -                  | YES        | -          |
| Programming speed                               | 9600-38400         | 9600-38400 | 9600-38400 |
| Battery   | YES                | YES        | YES        |
| Recipe memory                                   | 32KB               | 32KB       | 16KB       |
| Alarms  | 1024               | 1024       | 1024       |
| Events list                                     | 1024               | 1024       | 256        |
| Hardware clock                                  | YES                | YES        | YES        |
| Buzzer  | -                  | -          | -          |
| Max current consumption on 24VDC (mA)           | 600                | 500        | 250        |
| Suffix 45: dimensions WxHxD (mm) <sup>(2)</sup> | 275x220x80         | 216x168x82 | 138x186x82 |
| Suffix 50: dimensions WxHxD (mm) <sup>(3)</sup> | -                  | -          | -          |
| Max panel thickness (mm)                        | 5                  | 8          | 8          |
| Weight (Kg)                                     | 1.9                | 1.4        | 1.1        |

Table 1 - UniOP Technical Data

| <b>CP02R-04</b> | <b>CP10G-04</b> | <b>ePAD03</b> | <b>ePAD04</b> | <b>ePAD05</b> | <b>ePAD06</b> |
|-----------------|-----------------|---------------|---------------|---------------|---------------|
| 4x20 LCD        | 4x20 LCD        | 4x20 LCD      | 4x20 LCD      | 4x20 LCD      | 4x20 LCD      |
| LED             | LED             | LED           | LED           | LED           | LED           |
| -               | 120x32          | 120x32        | 120x32        | 120x32        | 120x32        |
| -               | 70x21           | 70x21         | 70x21         | 70x21         | 70x21         |
| -               | 2.8"            | -             | -             | -             | -             |
| 512KB           | 512KB           | 512KB         | 512KB         | 512KB         | 512KB         |
| up to 1MB       | up to 1MB       | -             | -             | -             | -             |
| 16              | 12              | 4             | 4             | 9             | 9             |
| 18              | 23              | 7             | 7             | 10            | 10            |
| -               | -               | -             | -             | -             | -             |
| 16              | 13              | 5             | 5             | 10            | 10            |
| 1               | 4               | 4             | 4             | 4             | 4             |
| YES             | YES             | -             | -             | -             | -             |
| YES             | YES             | YES           | YES           | YES           | YES           |
| YES             | YES             | YES           | YES           | YES           | YES           |
| -               | -               | -             | -             | -             | -             |
| -               | -               | -             | -             | -             | -             |
| -               | -               | -             | -             | -             | -             |
| -               | -               | -             | -             | -             | -             |
| 9600-38400      | 9600-38400      | 9600-38400    | 9600          | 9600-38400    | 9600          |
| YES             | YES             | YES           | -             | YES           | -             |
| 16KB            | 16KB            | 16KB          | -             | 16KB          | -             |
| 1024            | 1024            | 1024          | 1024          | 1024          | 256           |
| 256             | 256             | 256           | -             | 256           | -             |
| YES             | YES             | YES           | -             | YES           | -             |
| -               | -               | -             | -             | -             | -             |
| 250             | 300             | 250           | 250           | 250           | 250           |
| 138x186x82      | 141x176x76      | 149x109x55    | 149x109x55    | 149x109x55    | 149x109x55    |
| -               | 141x176x80      | -             | -             | -             | -             |
| 8               | 5               | 5             | 5             | 5             | 5             |
| 1.1             | 1.1             | 1             | 1             | 1             | 1             |

Table 1 - UniOP Technical Data

| Model   | ePAD33C     | eTOP03            | eTOP04C      |
|---|-------------|-------------------|--------------|
| Display   | 30x80 TFT   | LCD<br>monochrome | TFT<br>color |
| Backlight                                       | CCFL        | LED               | LED          |
| Graphics  | 640x480     | 320x240           | 480x272      |
| Display dimensions (mm)                         | 218x159     | 77x58             | 95.4x53.9    |
| Diagonal (inches)                               | 10.4"       | 3.8"              | 4.3"         |
| User memory                                     | 32MB        | 512KB             | 2MB          |
| User memory expansion                           | 16MB        | -                 | -            |
| Function keys                                   | 12          | -                 | -            |
| System keys                                     | 47          | -                 | -            |
| Touch screen                                    | -           | YES               | YES          |
| User LED's                                      | 24          | -                 | -            |
| System LED's                                    | 5           | -                 | 5            |
| PC/Printer Port                                 | YES         | -                 | -            |
| PLC Port  | YES         | YES               | YES          |
| AUX Port <sup>(1)</sup>                         | YES         | YES               | YES          |
| DX Port (video input)                           | -           | -                 | -            |
| Ethernet Port                                   | -           | -                 | YES          |
| USB Port  | -           | -                 | YES          |
| External keyboard Port                          | -           | -                 | -            |
| Programming speed                               | 9600-38400  | 9600-38400        | 9600-38400   |
| Battery   | YES         | YES               | YES          |
| Recipe memory                                   | 32 KB       | 32KB              | 32KB         |
| Alarms  | 1024        | 1024              | 1024         |
| Events list                                     | 1024        | 256               | 256          |
| Hardware clock                                  | YES         | YES               | YES          |
| Buzzer  | YES         | -                 | -            |
| Max current consumption on 24VDC (mA)           | 1200        | 400               | 400          |
| Suffix 45: dimensions WxHxD (mm) <sup>(2)</sup> | -           | 149x109x63        | 149x109x61   |
| Suffix 50: dimensions WxHxD (mm) <sup>(3)</sup> | 311x276x100 | -                 | -            |
| Max panel thickness (mm)                        | 4           | 5                 | 5            |
| Weight (Kg)                                     | 2.7         | 1                 | 1            |

Table 1 - UniOP Technical Data

| eTOP05         | eTOP05EB       | eTOP06     | eTOP06C    | eTOP20C    | eTOP33C    |
|----------------|----------------|------------|------------|------------|------------|
| TFT monochrome | TFT monochrome | TFT color  | TFT color  | TFT color  | TFT color  |
| LED            | LED            | LED        | LED        | CCFL       | CCFL       |
| 320x240        | 320x240        | 320x240    | 320x240    | 640x480    | 640x480    |
| 115x86         | 115x86         | 115x86     | 115x86     | 154x116    | 218x159    |
| 5.7"           | 5.7"           | 5.7"       | 5.7"       | 7.5"       | 10.4"      |
| 32MB           | 32MB           | 32MB       | 64MB       | 64MB       | 64MB       |
| -              | 32MB           | -          | Up to 64MB | Up to 64MB | Up to 64MB |
| 1              | 1              | 1          | 1          | 1          | 1          |
| -              | -              | -          | -          | -          | -          |
| YES            | YES            | YES        | YES        | YES        | YES        |
| 1              | 1              | 1          | 1          | 1          | 1          |
| 4              | 4              | 4          | 4          | 4          | 4          |
| YES            | YES            | YES        | YES        | YES        | YES        |
| YES            | YES            | YES        | YES        | YES        | YES        |
| YES            | YES            | YES        | YES        | YES        | YES        |
| -              | -              | -          | YES        | YES        | YES        |
| -              | -              | -          | YES        | YES        | YES        |
| -              | -              | -          | YES        | YES        | YES        |
| -              | -              | -          | -          | -          | -          |
| 9600-38400     | 9600-38400     | 9600-38400 | 9600-38400 | 9600-38400 | 9600-38400 |
| YES            | YES            | YES        | YES        | YES        | YES        |
| 32KB           | 32KB           | 32KB       | 32KB       | 32KB       | 32 KB      |
| 1024           | 1024           | 1024       | 1024       | 1024       | 1024       |
| 1024           | 1024           | 1024       | 1024       | 1024       | 1024       |
| YES            | YES            | YES        | YES        | YES        | YES        |
| YES            | YES            | YES        | YES        | YES        | YES        |
| 600            | 600            | 500        | 600        | 1100       | 1200       |
| 187x147x71     | 187x147x83     | -          | -          | 232x187x75 | -          |
| -              | 187x147x95     | 187x147x95 | 187x147x95 | 232x187x85 | 287x232x95 |
| 4              | 4              | 4          | 4          | 4          | 4          |
| 1.4            | 1.4            | 1.4        | 1.4        | 1.6        | 2.25       |

Table 1 - UniOP Technical Data

| Model   | eTOP40C      | eTOP50C      | ETT-VGA    |
|---|--------------|--------------|------------|
| Display   | TFT<br>color | TFT<br>color | 30x80 TFT  |
| Backlight                                       | CCFL         | CCFL         | CCFL       |
| Graphics  | 800X600      | 1024X768     | 640x480    |
| Display dimensions (mm)                         | 246x184      | 304X228      | 194x146    |
| Diagonal (inches)                               | 12.1"        | 15"          | 9.6"       |
| User memory                                     | 64MB         | 64MB         | 512KB      |
| User memory expansion                           | Up to 64MB   | Up to 64MB   | -          |
| Function keys                                   | 1            | 1            | 8          |
| System keys                                     | -            | -            | 3          |
| Touch screen                                    | YES          | YES          | YES        |
| User LED's                                      | 1            | 1            | 8          |
| System LED's                                    | 4            | 4            | 6          |
| PC/Printer Port                                 | YES          | YES          | YES        |
| PLC Port  | YES          | YES          | YES        |
| AUX Port <sup>(1)</sup>                         | YES          | YES          | YES        |
| DX Port (video input)                           | YES          | YES          | -          |
| Ethernet Port                                   | YES          | YES          | -          |
| USB Port  | YES          | YES          | -          |
| External keyboard Port                          | -            | -            | YES        |
| Programming speed                               | 9600-38400   | 9600-38400   | 9600-38400 |
| Battery   | YES          | YES          | YES        |
| Recipe memory                                   | 32 KB        | 32 KB        | 32KB       |
| Alarms  | 1024         | 1024         | 1024       |
| Events list                                     | 1024         | 1024         | 1024       |
| Hardware clock                                  | YES          | YES          | YES        |
| Buzzer  | YES          | YES          | -          |
| Max current consumption on 24VDC (mA)           | 1000         | 1500         | 700        |
| Suffix 45: dimensions WxHxD (mm) <sup>(2)</sup> | -            | -            | 311x220x89 |
| Suffix 50: dimensions WxHxD (mm) <sup>(3)</sup> | 337x267x95   | 392x307x104  | -          |
| Max panel thickness (mm)                        | 4            | 4            | 9          |
| Weight (Kg)                                     | 2.8          | 3.8          | 2.7        |

Table 1 - UniOP Technical Data

| <b>MD02R-04</b> | <b>MKDG-06</b> | <b>MKDR-04</b> | <b>MKDR-05</b> | <b>MKDR-16</b> |
|-----------------|----------------|----------------|----------------|----------------|
| 4x20 LCD        | 8x40 LCD       | 4x40 LCD       | 4x40 LCD       | 16x40 LCD      |
| LED             | CCFL           | LED            | LED            | CCFL           |
| -               | 240x64         | -              | -              | 320x240        |
| -               | 127x34         | -              | -              | 121x91         |
| -               | 5.2"           | -              | -              | 5.6"           |
| 512KB           | 512KB          | 512KB          | 512KB          | 512KB          |
| -               | 1024KB         | up to 1MB      | up to 1MB      | Up to 1MB      |
| 9               | 23             | 16             | 20             | 16             |
| 10              | 24             | 29             | 18             | 19             |
| -               | -              | -              | -              | -              |
| 9               | 24             | 24             | 26             | 24             |
| 2               | 5              | 5              | 4              | 5              |
| YES             | YES            | YES            | YES            | YES            |
| YES             | YES            | YES            | YES            | YES            |
| YES             | YES            | YES            | YES            | YES            |
| -               | -              | -              | -              | -              |
| -               | -              | -              | -              | -              |
| -               | -              | -              | -              | -              |
| -               | -              | YES            | YES            | YES            |
| 9600-38400      | 9600-38400     | 9600-38400     | 9600-38400     | 9600-38400     |
| YES             | YES            | YES            | YES            | YES            |
| 16KB            | 16KB           | 16KB           | 16KB           | 32KB           |
| 1024            | 1024           | 1024           | 1024           | 1024           |
| 256             | 256            | 256            | 256            | 1024           |
| YES             | YES            | YES            | YES            | YES            |
| -               | -              | -              | -              | -              |
| 250             | 400            | 400            | 350            | 500            |
| 195x98x82       | 220x176x73     | 311x165x89     | 311x111x89     | 311x220x89     |
| 195x98x90       | 220x176x85     | -              | -              | -              |
| 8               | 5              | 9              | 9              | 9              |
| 0.9             | 1.2            | 1.9            | 1.8            | 2.5            |

Table 1 - UniOP Technical Data

Notes :

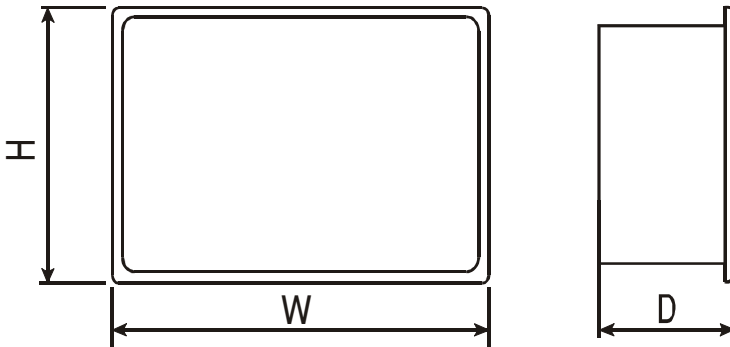

- (1) With optional module.
- (2) Suffix 45: for operator panel which have suffix A6, A7, 45.
- (3) Suffix 50: for operator panel which have suffix 50.

### Installation

UniOP panels are designed to be mounted on the front of some type of enclosure. The bezel height, bezel width and the cut-out dimensions for each panel type are given in the following pages.

*Note: remove the red BATTERY PROTECTION strip before installation*

### Physical Dimensions

All measurements are given in mm, with tolerance  $\pm 0.5$ .

#### MD02R-04

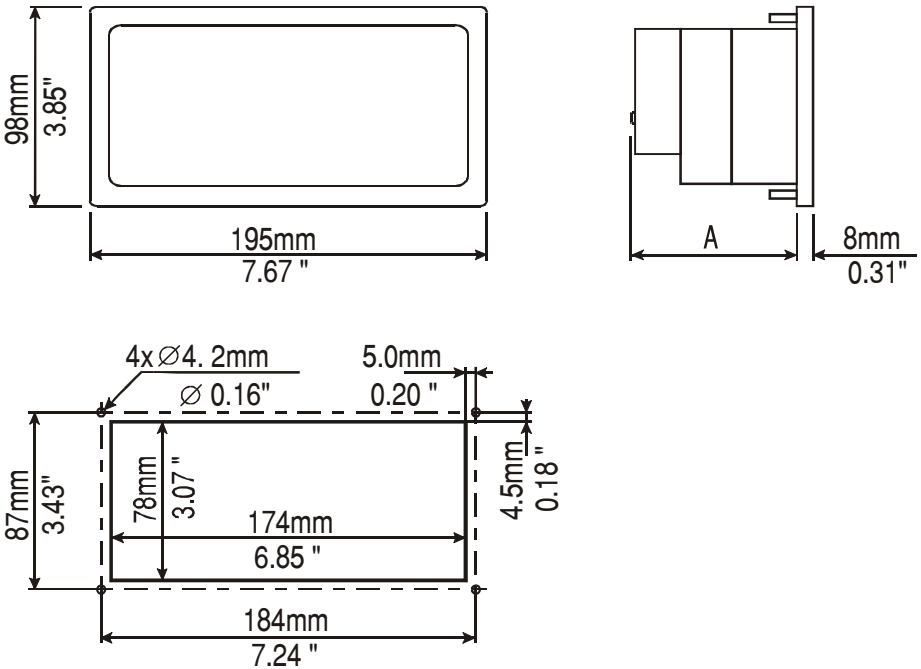

A = 74mm 2.91" for operator panel which have suffix A6, A7, 45.  
82mm 3.2" for operator panel which have suffix 50

Figure 1 - Dimensions



CP10G-04

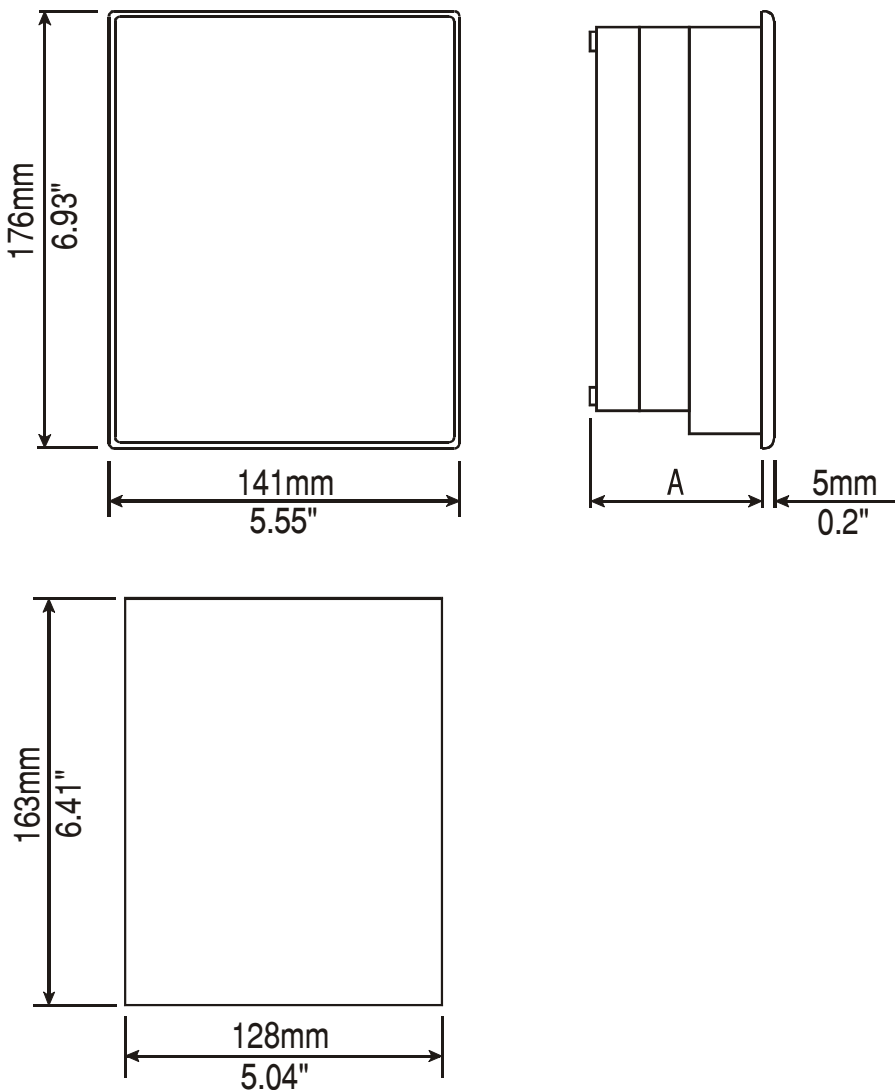

A = 71mm 2.8" for operator panel which have suffix A6, A7, 45.  
 75mm 2.9" for operator panel which have suffix 50

Figure 2 - Dimensions

CP01R-04, CP02R-04

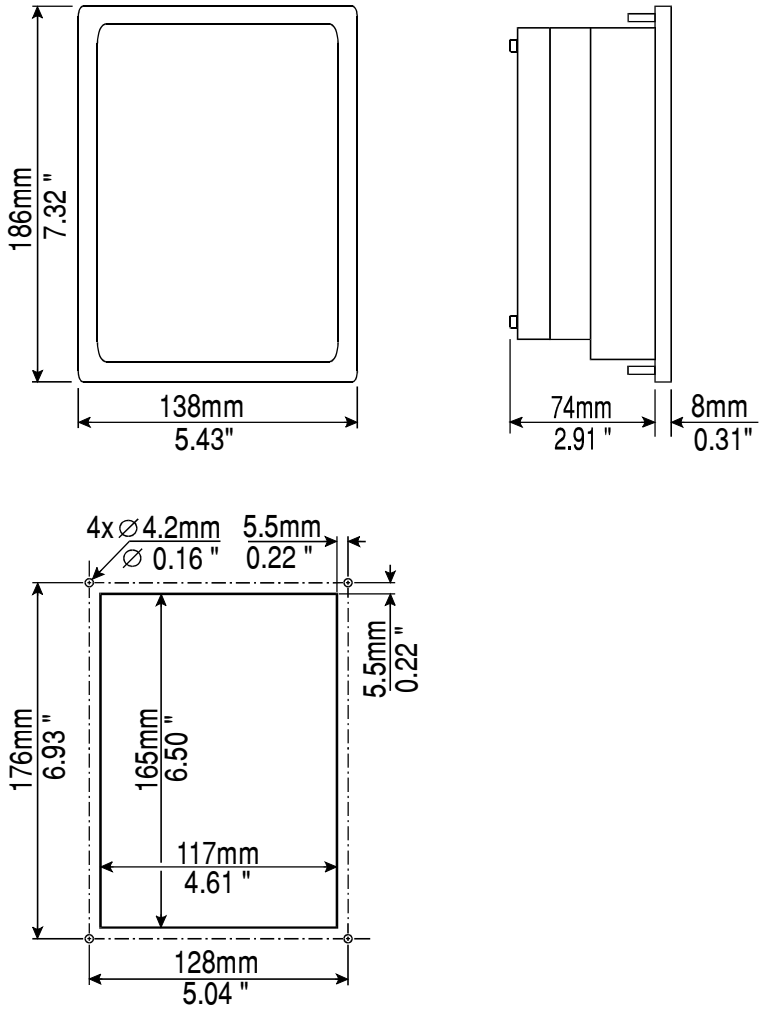

Figure 3 - Dimensions

BKDR-16

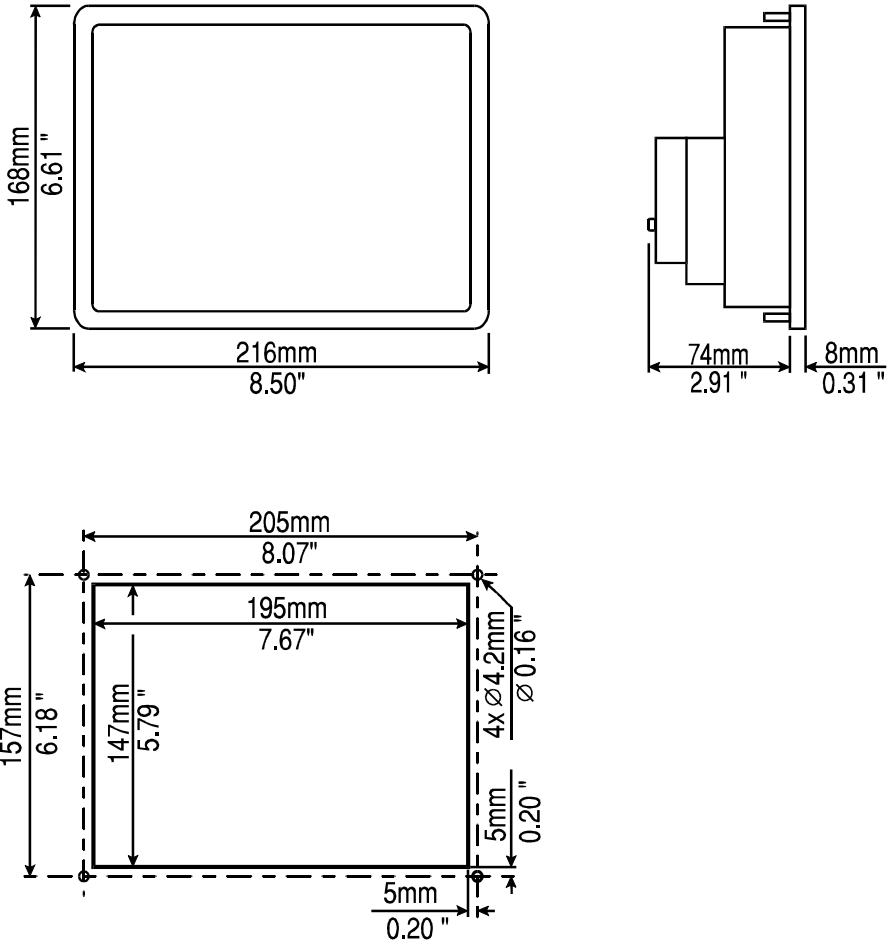

Figure 4 – Dimensions

**BKDC-46**

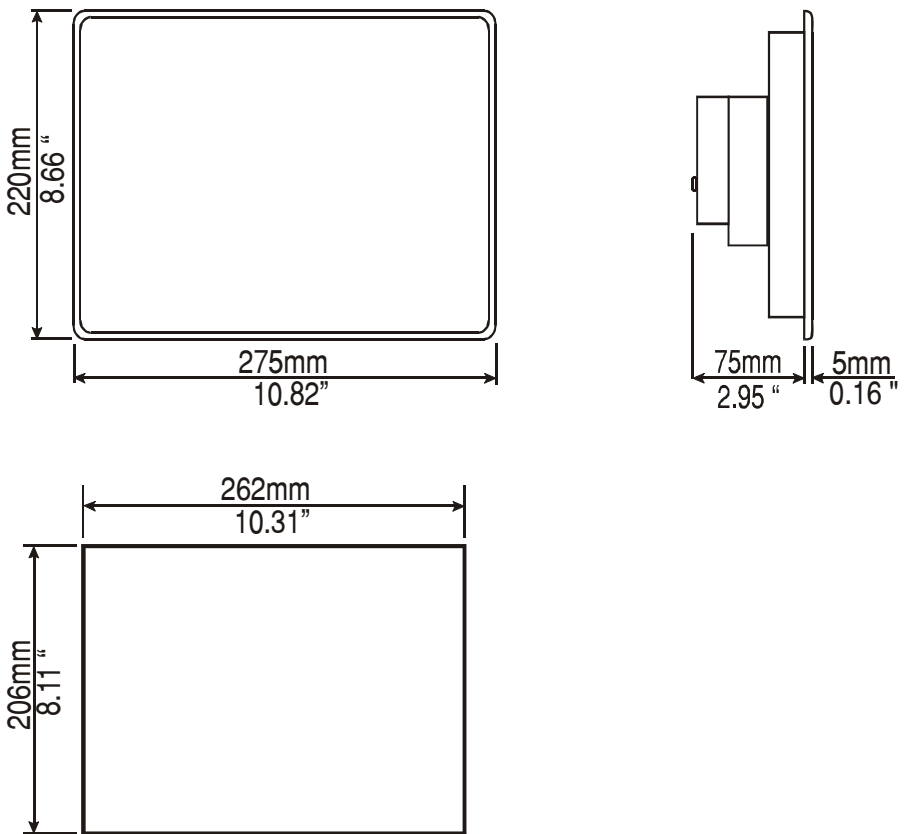

Figure 5 - Dimensions

**MKDR-05**

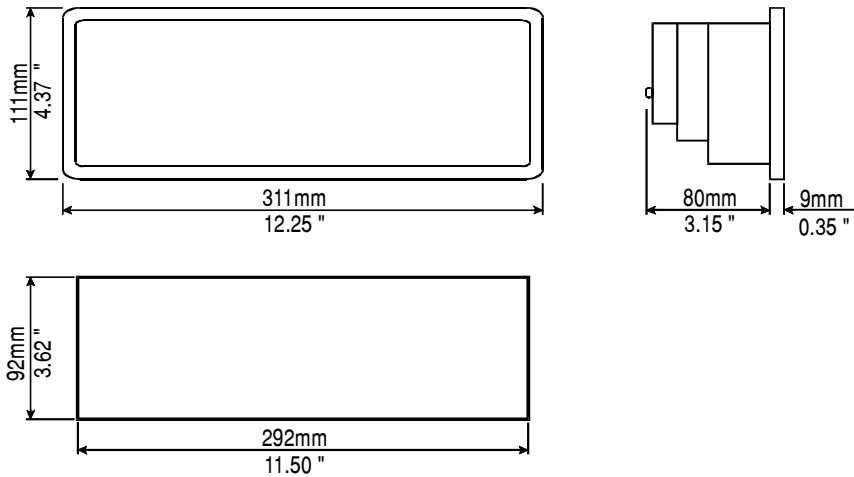

Figure 6 - Dimensions

**MKDR-04**

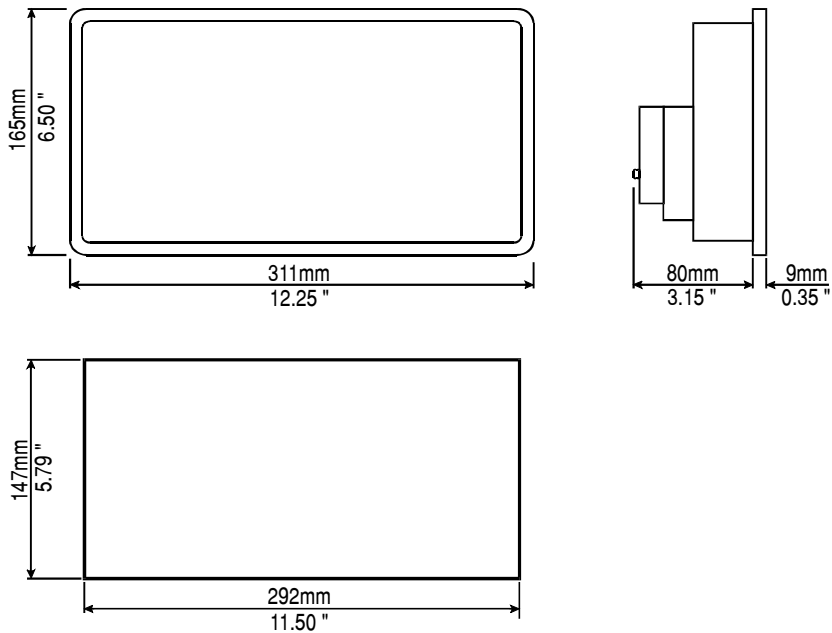

Figure 7 - Dimensions

ePAD03, ePAD04, ePAD05, ePAD06

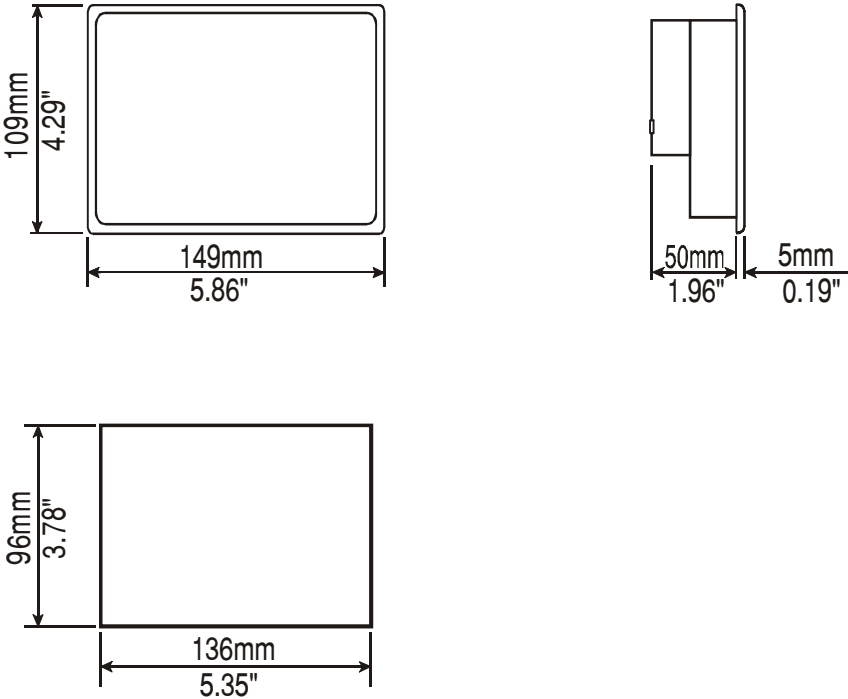

Figure 8 - Dimensions

eTOP03

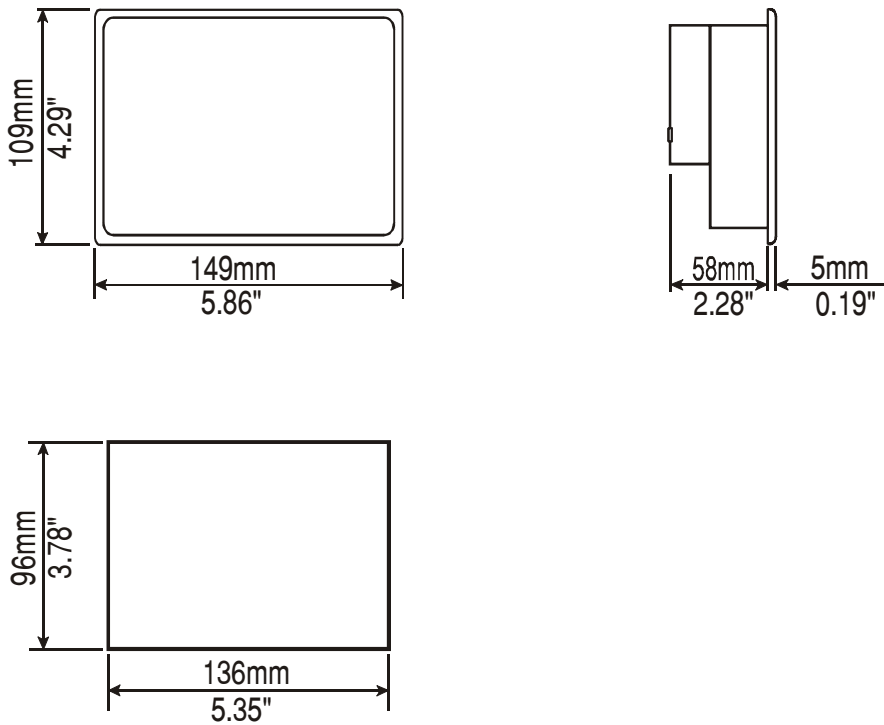

Figure 9 - Dimensions

eTOP04C

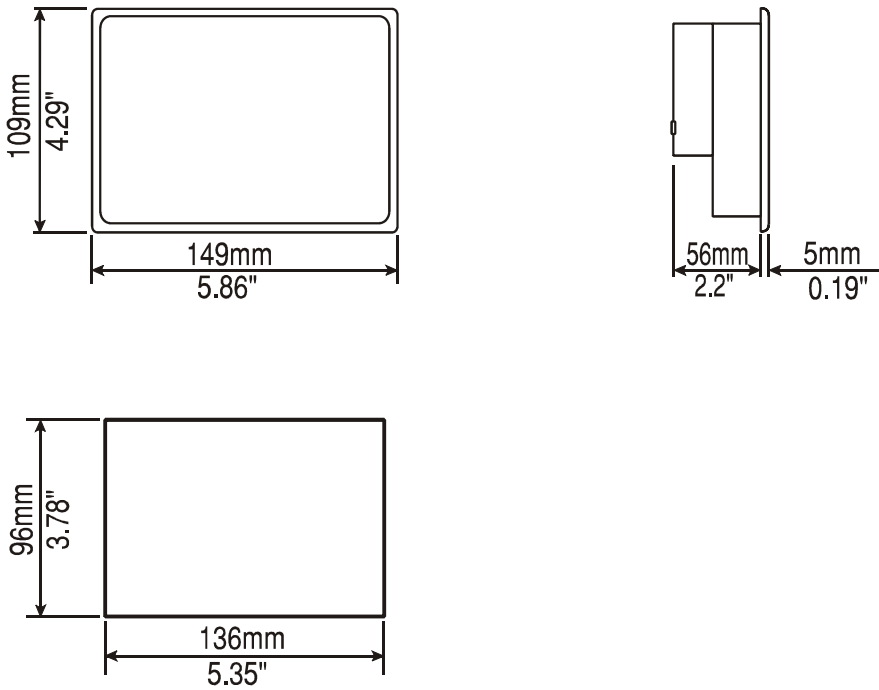

Figure 10 - Dimensions



eTOP05

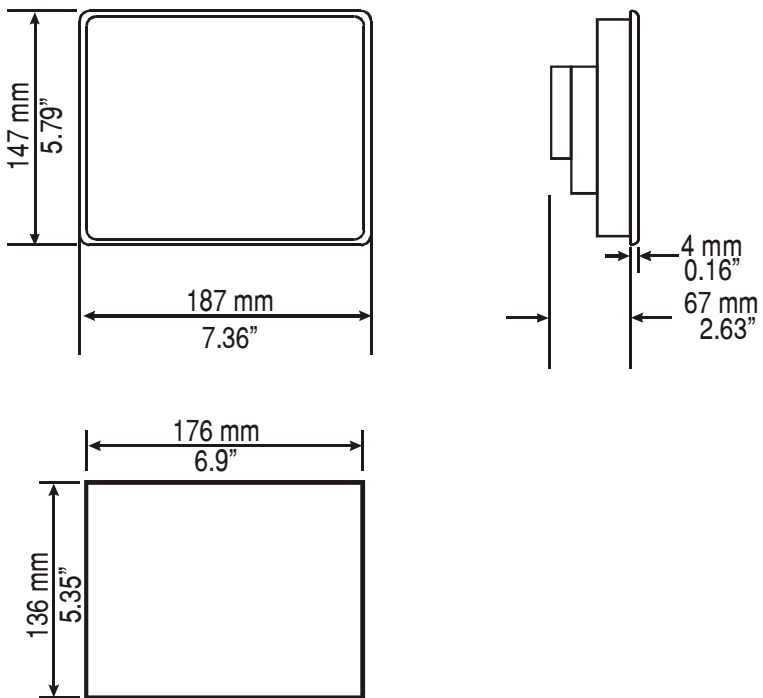
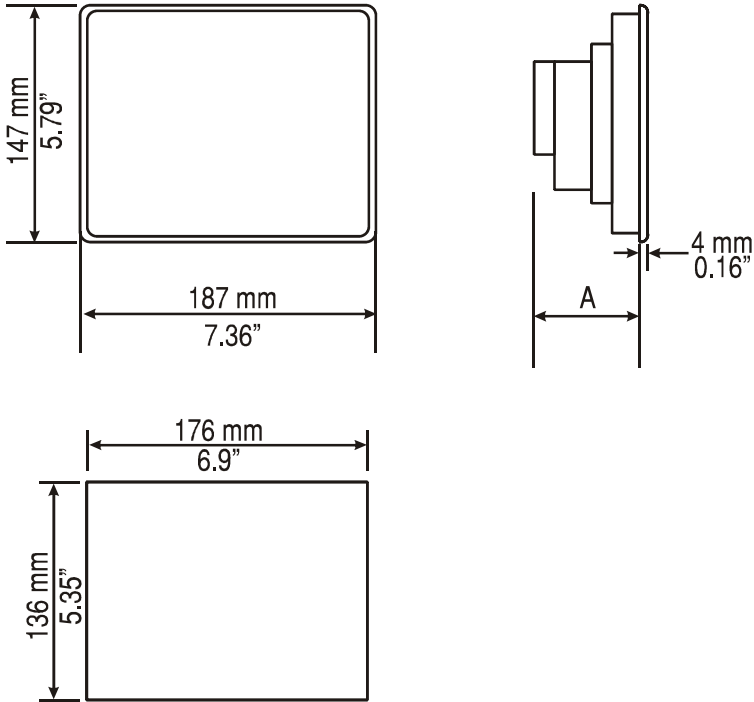

Figure 11 - Dimensions

eTOP05EB, eTOP06, eTOP06C



A = 83mm 3.2" for operator panel which have suffix 45.  
95mm 3.7" for operator panel which have suffix 50

Figure 12 - Dimensions

eTOP20C

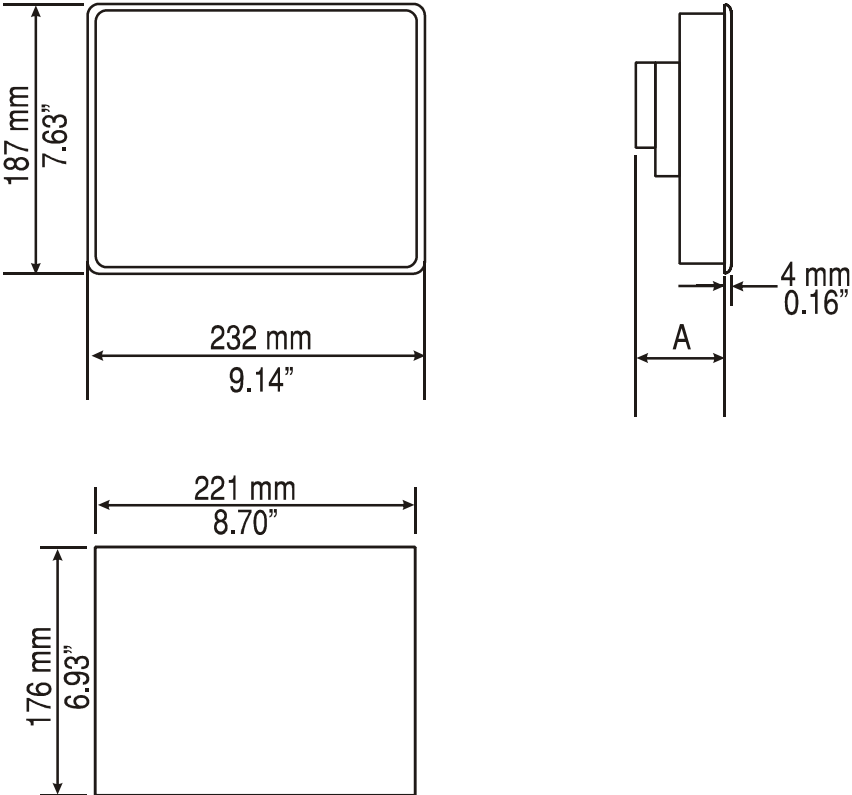

A = 75mm 2.9" for operator panel which have suffix 45.  
85mm 3.3" for operator panel which have suffix 50

Figure 13 - Dimensions

eTOP33C

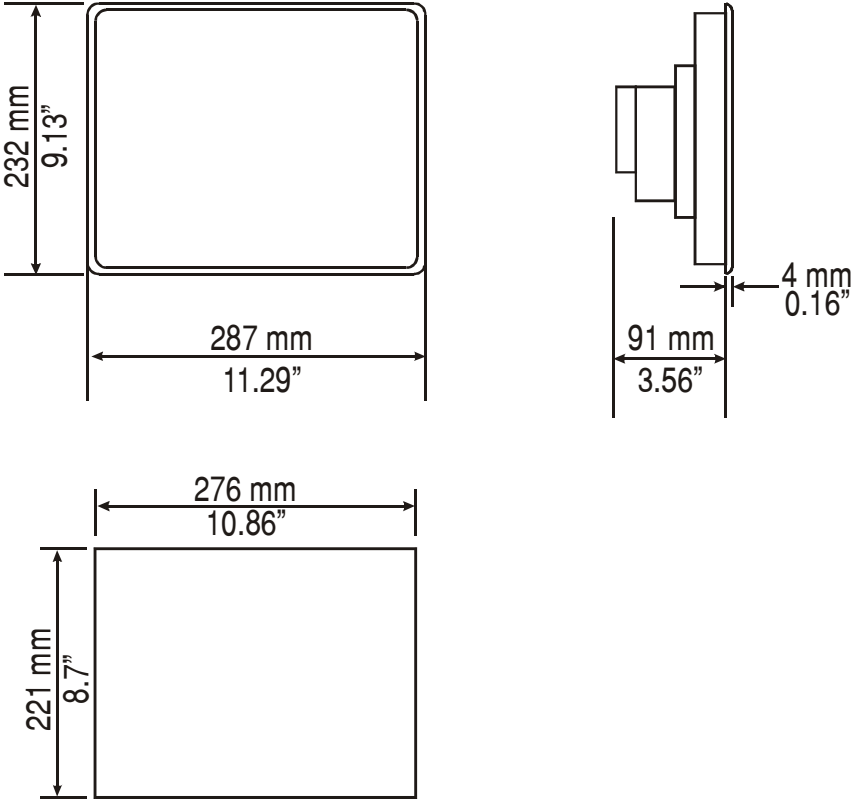

Figure 14 – Dimensions

eTOP40C

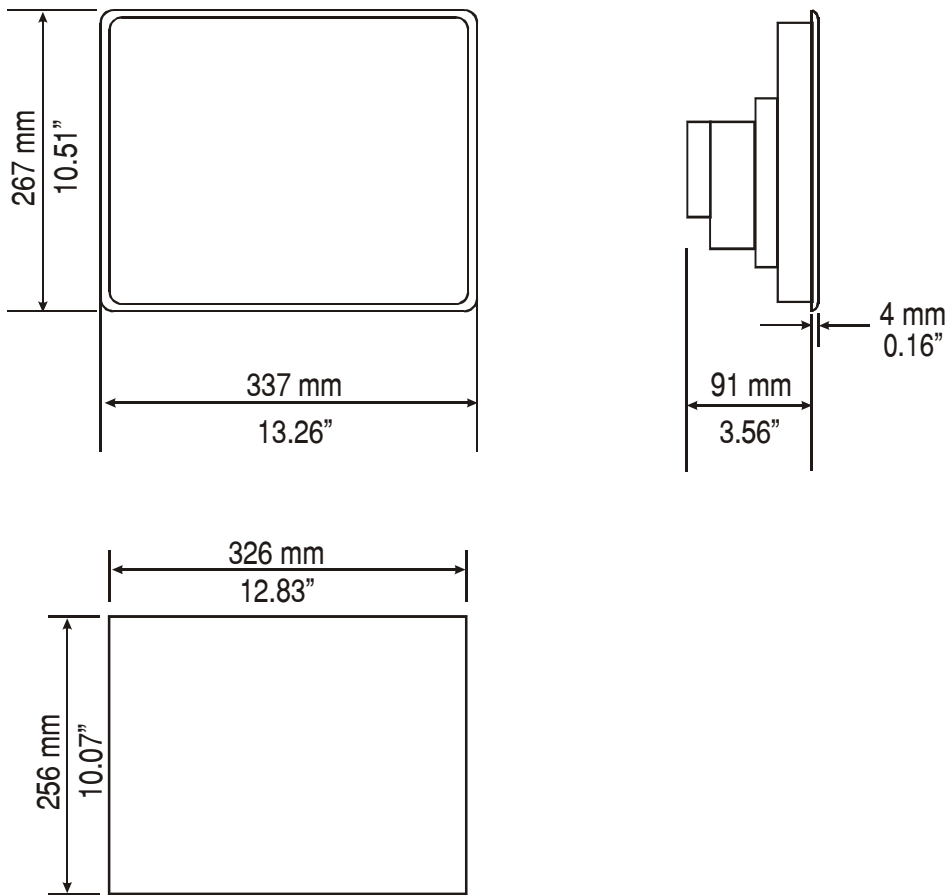

Figure 15 - Dimensions

eTOP50C

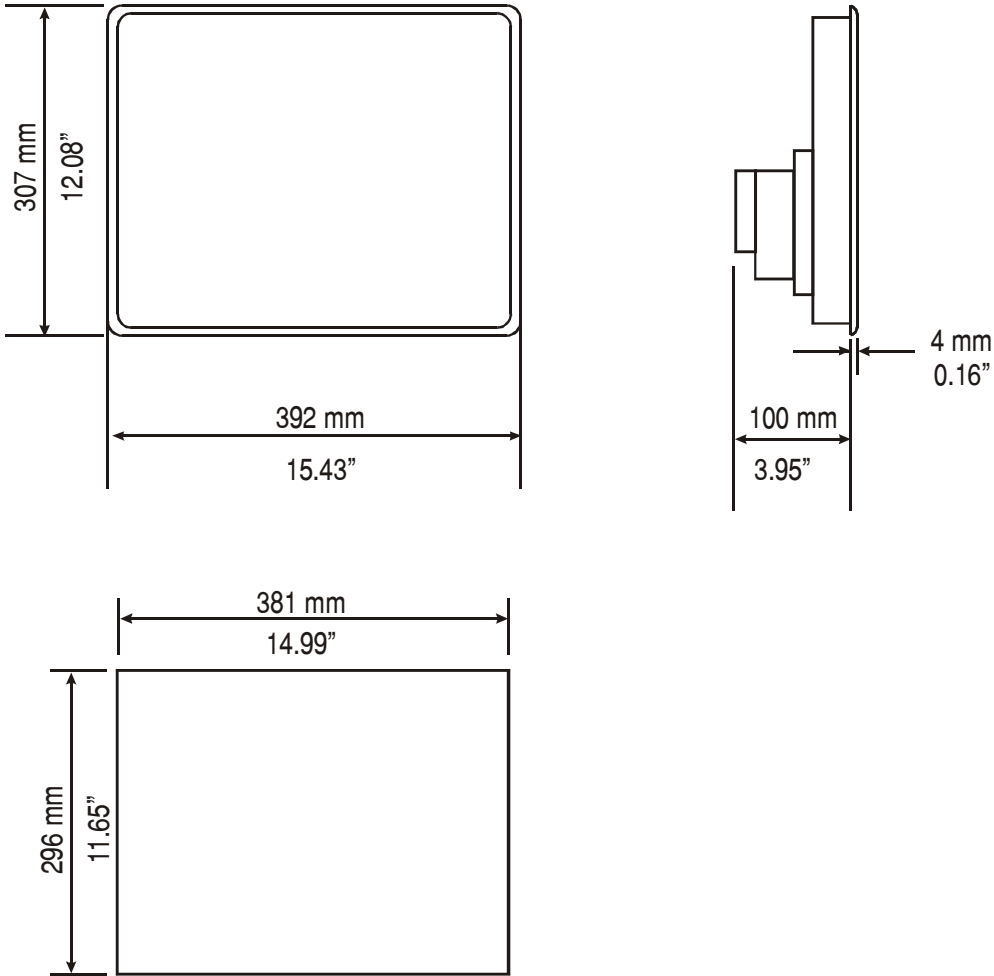
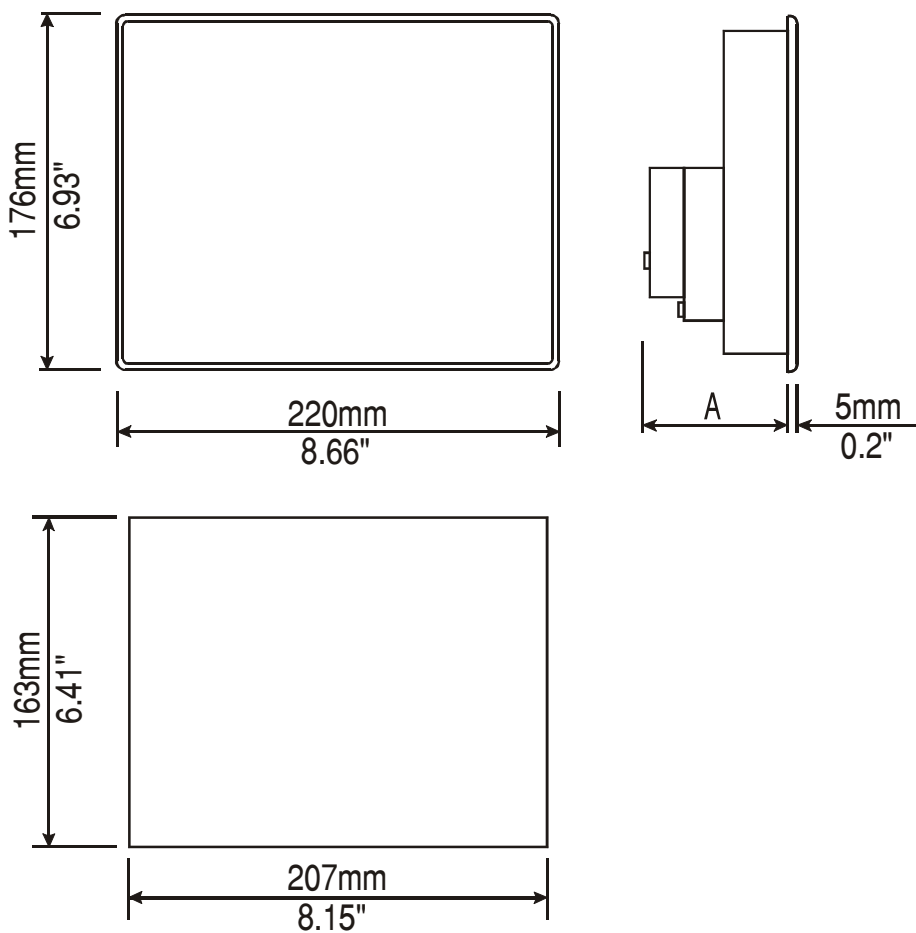

Figure 16 - Dimensions

**MKDG-06**



A = 68mm 2.8" for operator panel which have suffix A6, A7, 45.  
 80mm 3.1" for operator panel which have suffix 50.

Figure 17 - Dimensions

**ETT-VGA, MKDR-16**

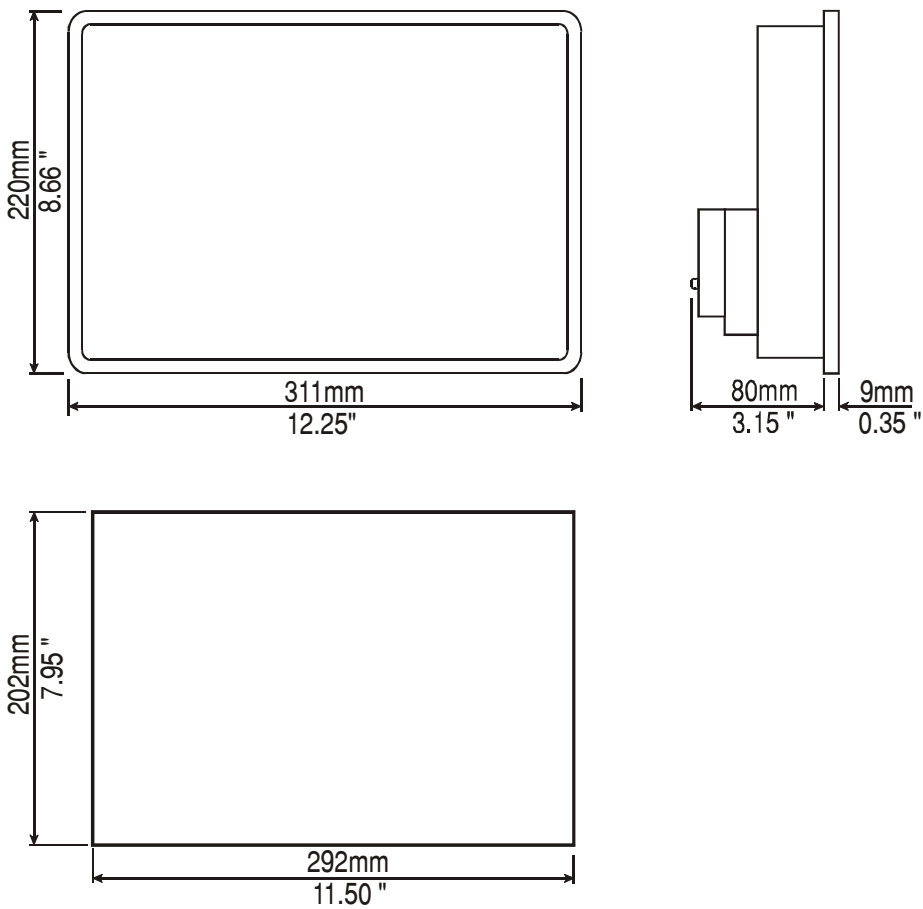

Figure 18 - Dimensions



ePAD33C

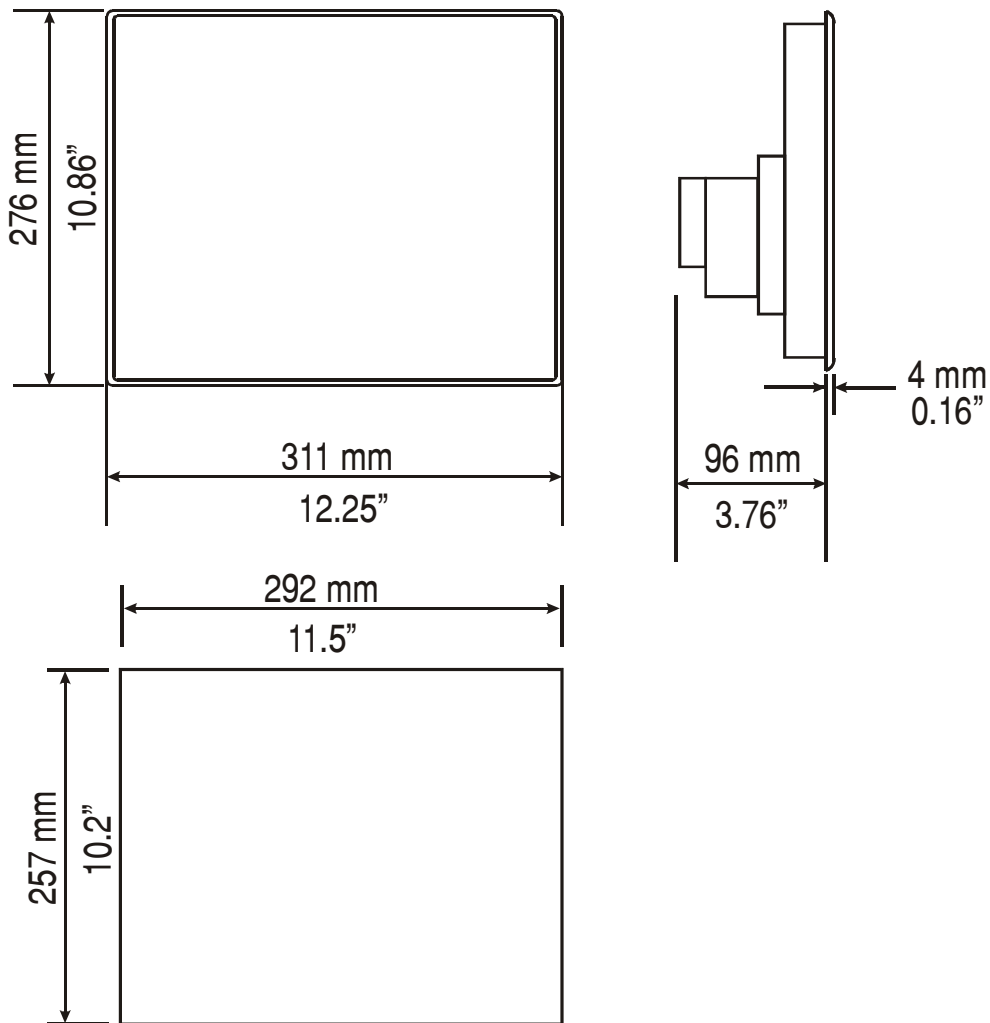

Figure 19 - Dimensions

**Connections**

**MD02R-04**

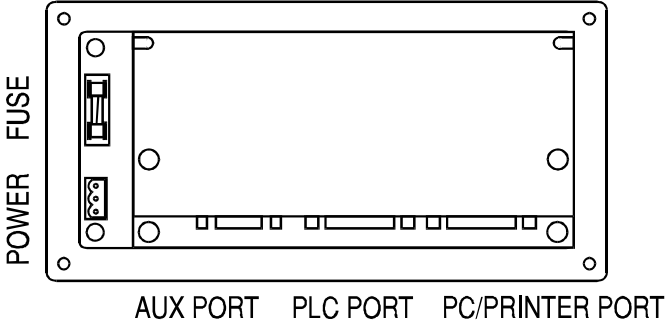

Figure 20 - Connectors

**CP01R-04, CP02R-04**

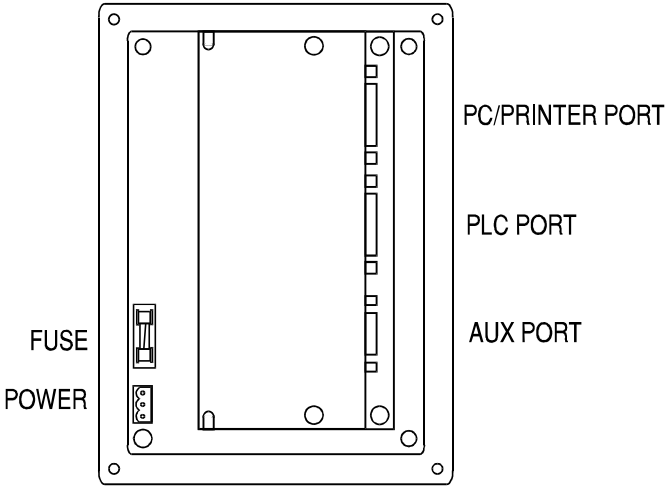

Figure 21 - Connectors

**CP10G-04**

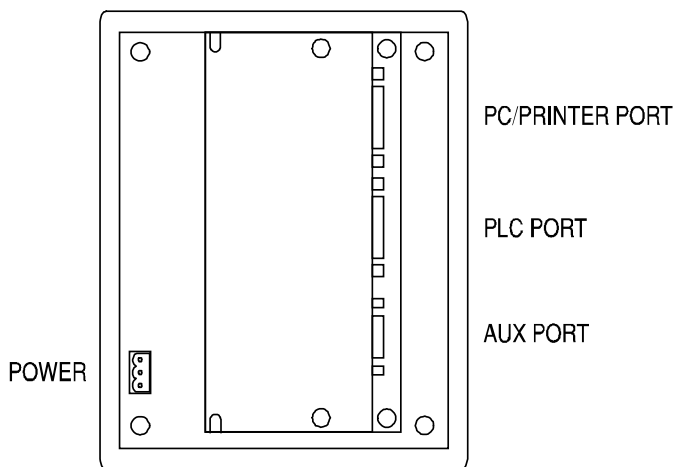

Figure 22 - Connectors

**BKDR-16**

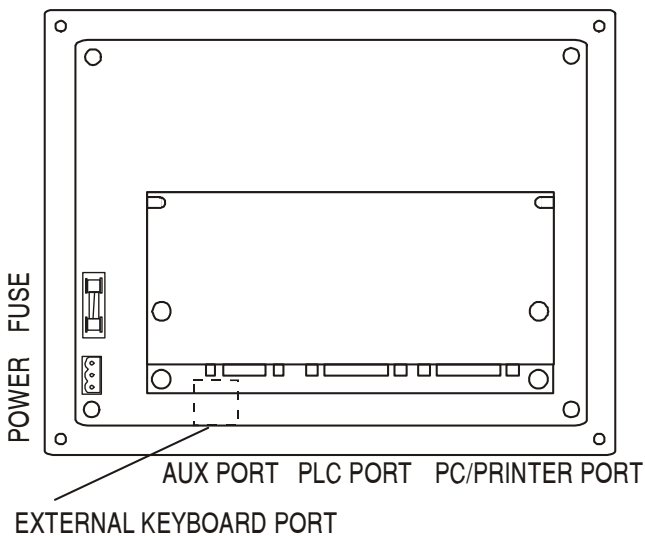

Figure 23 - Connectors

**MKDG-06**

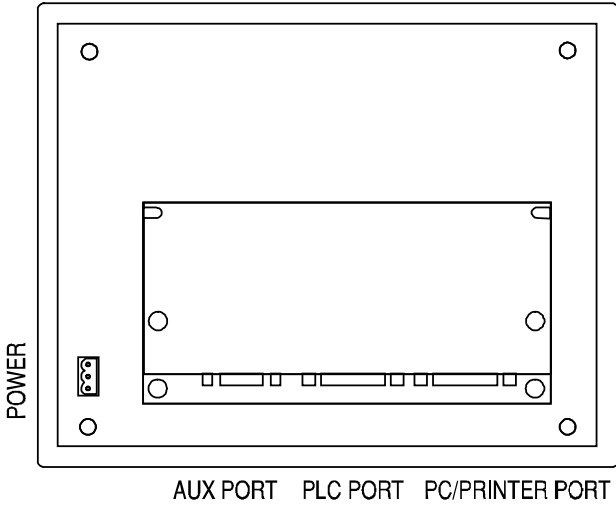
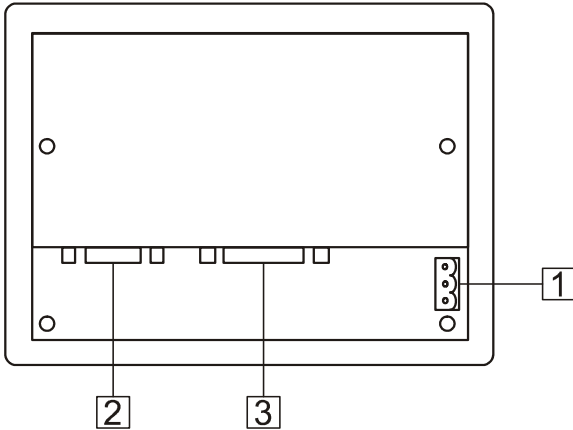

Figure 24 - Connectors

**ePAD03, ePAD04, ePAD05, ePAD06**



- 1. Power
- 2. Aux Port
- 3. PLC Port

Figure 25 - Connectors

**eTOP03**

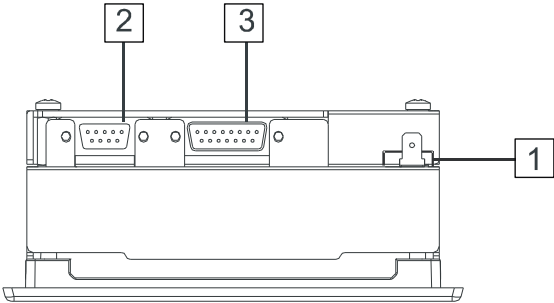

- 1. Power
- 2. Aux Port
- 3. PLC Port

Figure 26 - Connectors

**eTOP04C**

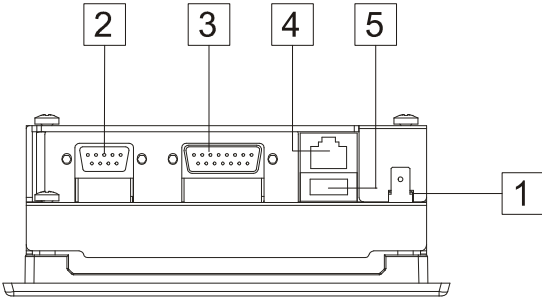

- 1. Power
- 2. Aux Port
- 3. PLC Port
- 4. Ethernet Port
- 3. USB Port (only for

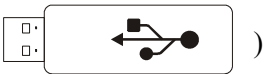

Figure 27 - Connectors

**eTOP05, eTOP05EB, eTOP06**

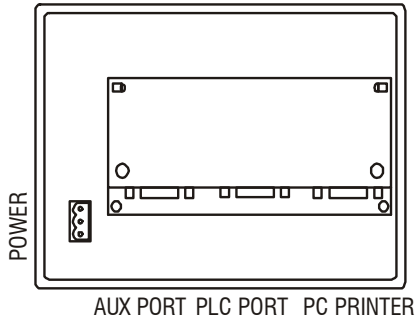
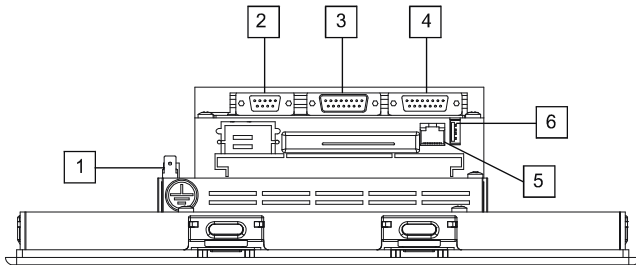

Figure 28 - Connectors

**eTOP06C, eTOP20C, eTOP33C, eTOP40C, eTOP50C**



- 1. Power
- 2. Aux Port
- 3. PLC Port
- 4. PC/Printer Port
- 5. Ethernet Port
- 6. USB Port (only for



Figure 29 - Connectors

**MKDR-05**

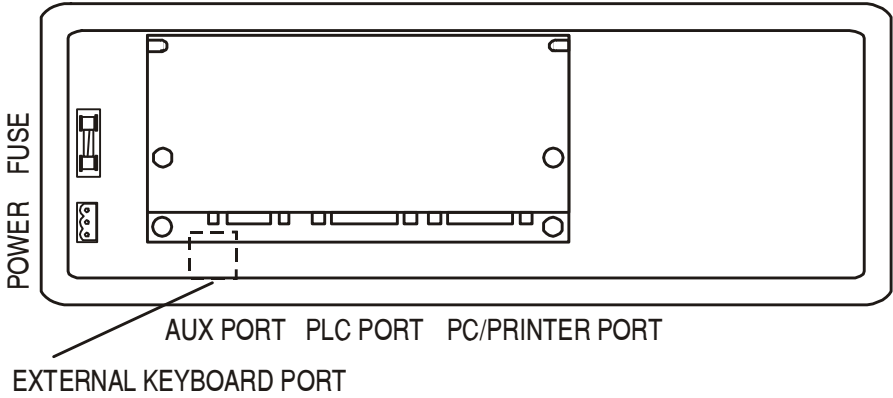

Figure 30 - Connectors

**MKDR-04**

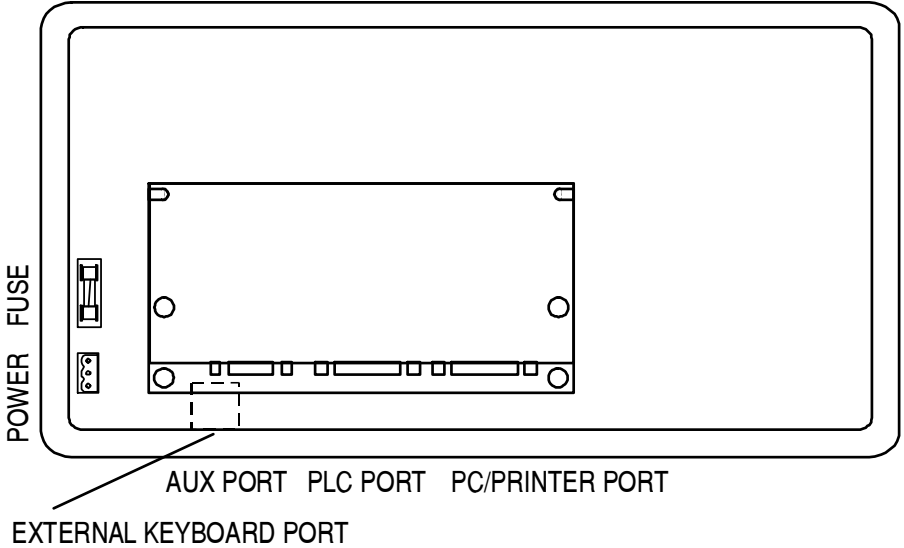

Figure 31 - Connectors

**BKDC-46**

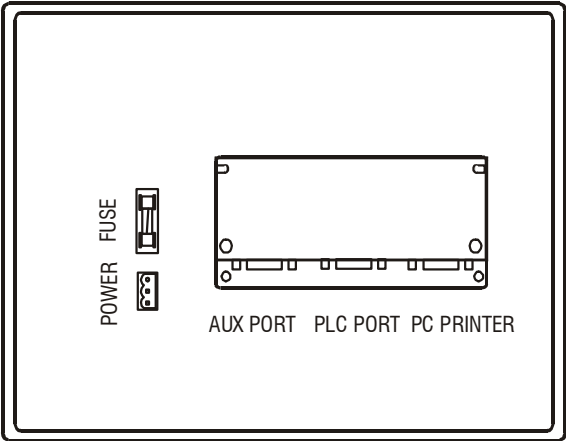

Figure 32 - Connectors



ETT-VGA, MKDR-16

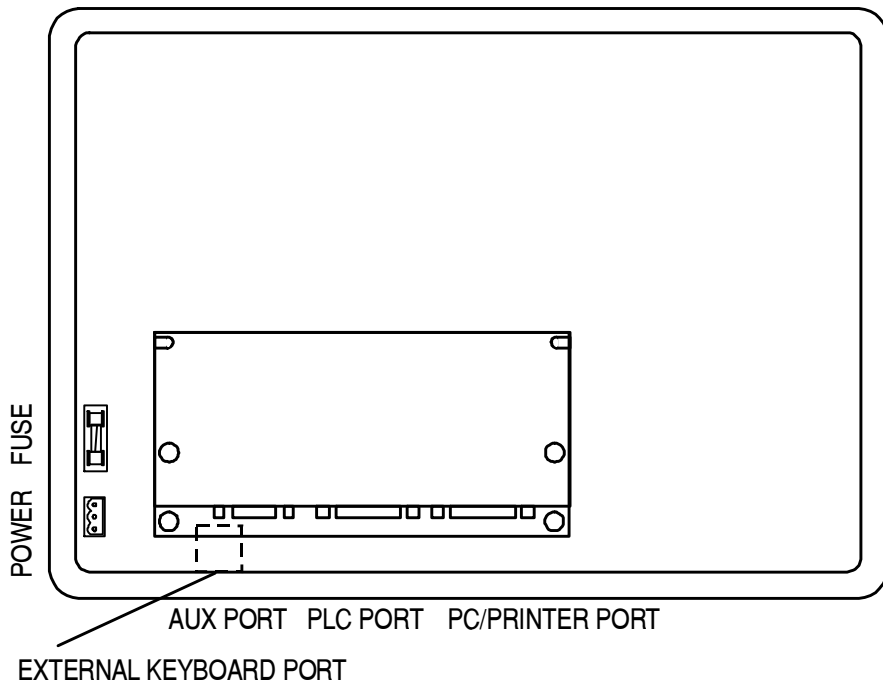

Figure 33 - Connectors

ePAD33C

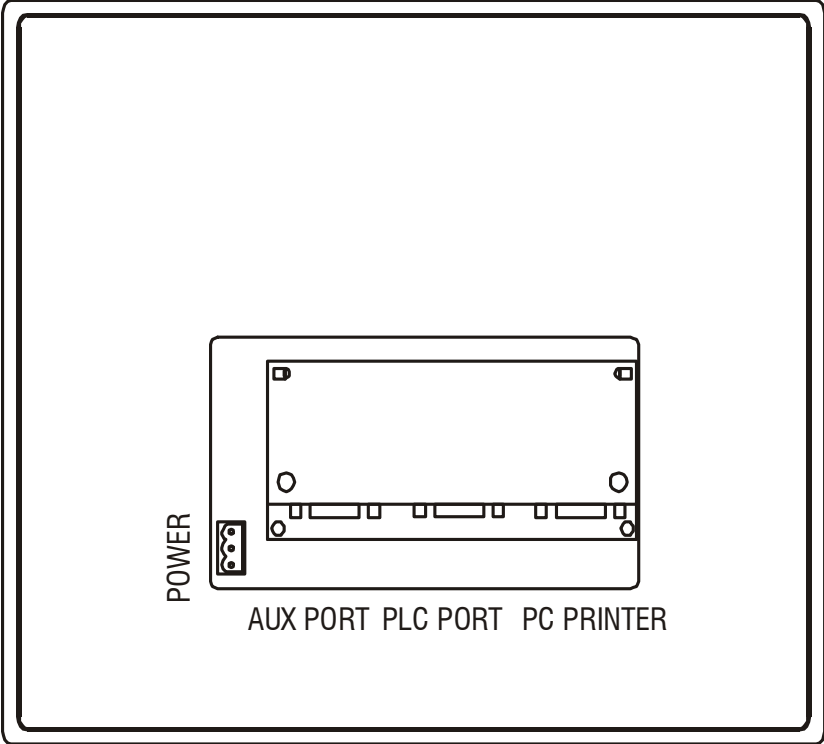

Figure 34 - Connectors

**Power Supply and Grounding**

The power supply terminal block is shown in the figure below. The terminal block is included with the panel.

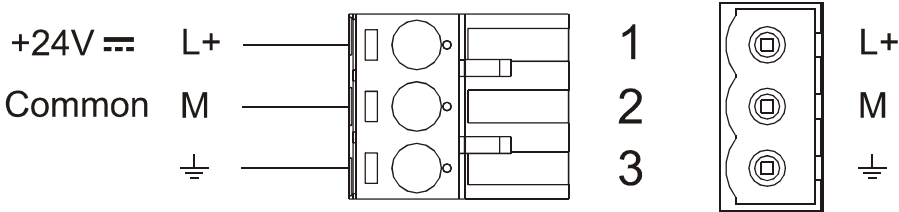

Figure 35 - Power supply terminal block

*Note: ensure that the power supply has enough power capacity for the operation of the equipment.*

The unit must always be grounded to earth. Grounding helps limit the effects of noise due to electromagnetic interference on the control system.

Earth connection will have to be done using either either the screw or the faston terminal located near the power supply terminal block. A yellow label help identify the ground connection. Also connect to ground the terminal 3 on the power supply terminal block.

The power supply circuit may be floating or grounded. In the latter case connect to ground the power source common as shown in figure 42 with a dashed line.

When using the floating power scheme, note that the panels internally connect the power common to ground with a 1 MΩ resistor in parallel with a 4,7 nF capacitor.

The power supply must have double or reinforced insulation

The suggested wiring for the power supply is shown in figure 36.

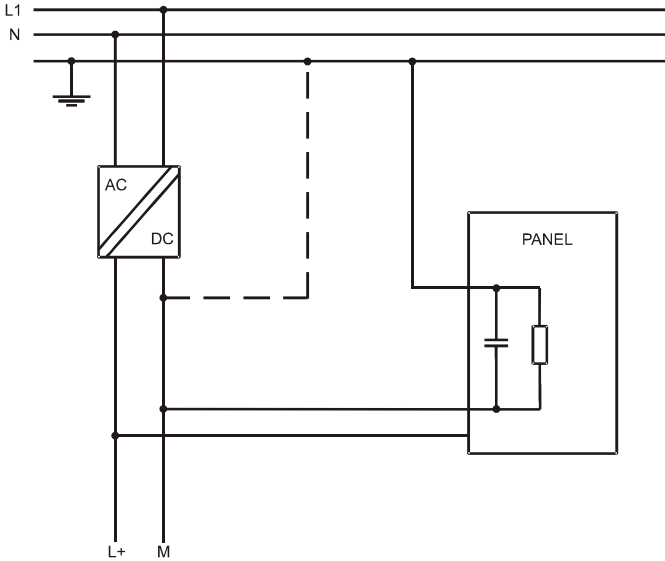

Figure 36 - Power supply

All the electronic devices in the control system must be properly grounded. Grounding must be performed according to applicable regulations.

### PLC Port

The PLC Port is used to communicate with the PLC or with another type of controller; if the panel is configured as an UniNET client, then this port may be used for the network connection.

Different electrical standards are available for the signals in the PLC port connector: RS-232, RS-422, RS-485 or Current Loop 20 mA. The cable used selects the appropriate signals. It is always necessary to use the correct cable type for on the PLC to be connected.

*Note: If the proper cable is not used, communication with the PLC will not be possible.*

The connector is a D-15 pin male. Pin assignment is shown in the table below.

| Pin | Description             |
|-----|-------------------------|
| 1   | Frame Ground            |
| 2   | RXD                     |
| 3   | TXD                     |
| 4   | +5 V output (Max 100mA) |
| 5   | GND                     |
| 6   | CHA-                    |
| 7   | CHB-                    |
| 8   | TX+ 20 mA               |
| 9   | TX- 20 mA               |
| 10  | RTS                     |
| 11  | CTS                     |
| 12  | RX+ 20 mA               |
| 13  | RX- 20 mA               |
| 14  | CHA+                    |
| 15  | CHB+                    |

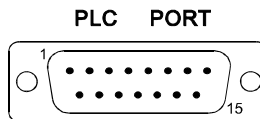

Figure 37 - PLC Port connector and pin assignment

The communication cable must be chosen for the type of device being connected.

### PC/Printer Port

The function of the PC/Printer Port depends on the mode of operation of the panel.

|  |                              |
|--|------------------------------|
| Configuration Mode                               | programming port             |
| Operation Mode, UniNET Server                    | connection to UniNET         |
| Operation Mode, UniNET not active or Client node | connection to serial printer |

Only RS232 signals are available on the PC/Printer Port. The connector is a D-15 pin female. Pin assignment is shown in the table below.

| Pin | Description             |
|-----|-------------------------|
| 1   | Frame Ground            |
| 2   | RXD                     |
| 3   | TXD                     |
| 4   | +5 V output (max 100mA) |
| 5   | GND                     |
| 6   | Reserved                |
| 7   | Reserved                |
| 8   | Reserved                |
| 9   | Reserved                |
| 10  | RTS                     |
| 11  | CTS                     |
| 12  | Reserved                |
| 13  | Reserved                |
| 14  | Reserved                |
| 15  | Reserved                |

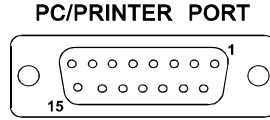

Figure 38 - PC/Printer Port connector and pin assignment

Use cable CA2 to connect the panel to a PC for programming. The diagram is shown in the figure below. The connector is a D-9 pin female.

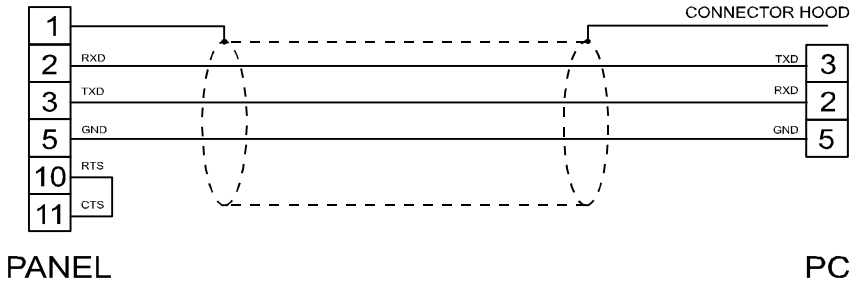

Figure 39 - Programming cable CA2

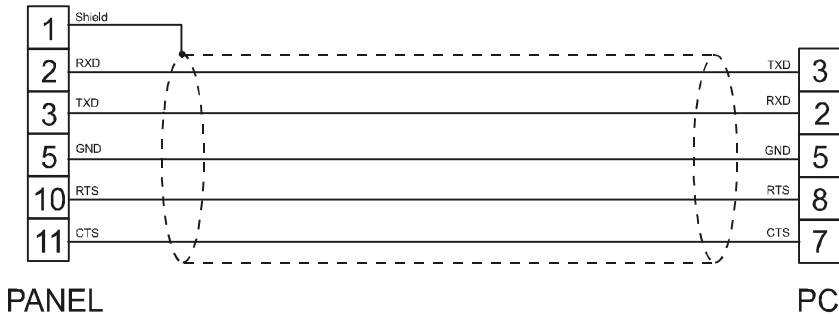

Figure 40 - Programming cable CA114

When the panel is in Operation Mode and is not as a UniNET Server, you can attach a serial printer to the PC/Printer Port. The communication parameters for the printer are defined by the application program (project file)

*Note: the communication cable to the printer depends on the communication interface of the printer.*

**AUX Port**

The AUX Port is a communication port specially designed for industrial network communication. The AUX Port connector is a 9 pin D sub type. The functionality of the AUX Port depends on the optional communication module which is plugged into the unit.

*Note: The pin assignment of the Aux Port connector is described in the manual of the communication module.*

The procedure to mount the communication modules is the following:

- 1) turn off the unit
- 2) partially unscrew with a screwdriver the 2 screws holding the rear cover. The screws are labelled 'A' in Figure 44
- 3) remove the cover (for eTOP05/05EB/06/06C/20C/33C/40C/50C and ePAD33C lever with screwdriver on the slot on the cover's side).
- 4) plug the module in the red connectors; make sure the connectors are locked
- 5) replace the rear cover
- 6) fix the 2 screws 'A' (for eTOP05/05EB/06/06C/20C/33C/40C/50C and ePAD33C close the cover with a little pressure).
- 7) stick in the area 'B' the label describing the functionality of the AUX Port. The label is delivered with the modules

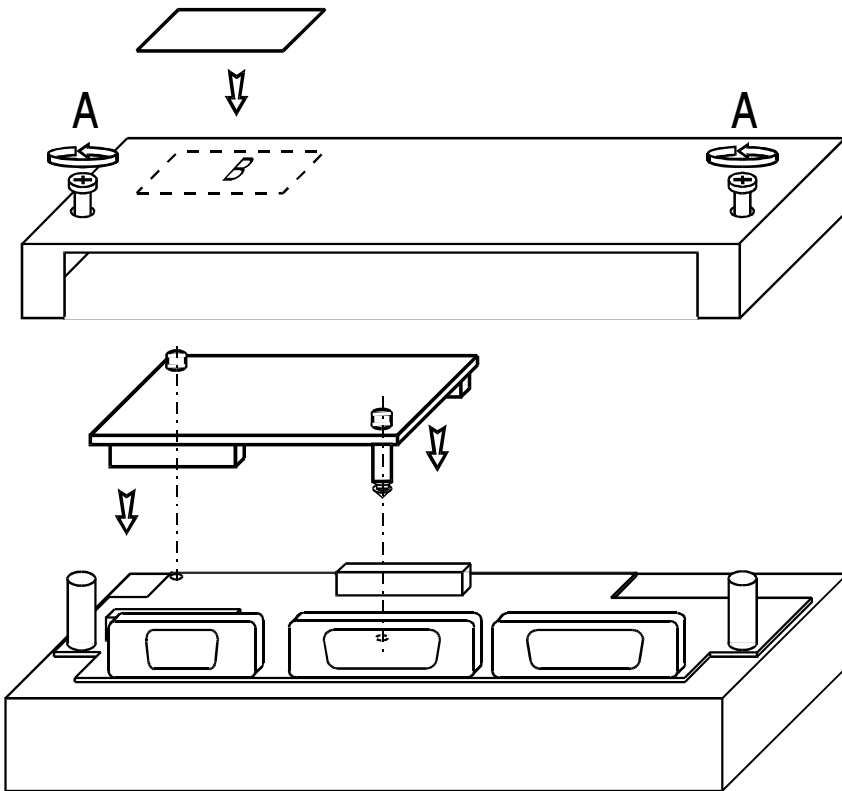
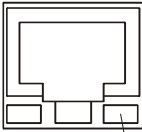

Figure 41 - Mounting the communication modules



**Ethernet Port**

| Pin | Description |
|-----|-------------|
| 1   | TX OUT +    |
| 2   | TX OUT -    |
| 3   | RX OUT +    |
| 4   |             |
| 5   |             |
| 6   | RX OUT -    |
| 7   |             |
| 8   |             |



ON: Valid link has NOT been detected  
 OFF: Valid link has been detected

**Models without the PC/Printer Port**

Some UniOP models, see Table 1, do not have the PC/Printer Port. The PLC Port will be referred to as the PLC/PC Port, and will be used as a programming port when the panel is in Configuration Mode. You must use a gender changer with the CA2/CA114 cable to program these units.

**External Keyboard Port**

Several UniOP models, see Table 1, are equipped with a connector designed to connect an external keyboard type ET-F or AT-F. The communication cable comes with the keyboards.

## Battery Replacement

Some models require the use of the lithium battery for data back-up.

The following information is maintained by the battery:

- hardware real-time clock (date and time)
- event list
- recipe data

UniOP panels signal the battery status in more than one way:

- blinking of the LED indicator FAULT or FLT (when available) or 
- with the 'Battery' field in System Menu (BATTERY OK or LOW)
- with the value of the S6 bit in the RDA

When the panel signals that the battery is low, you should replace the battery as soon as possible.

**Note:** *Replacing the battery will cause the loss of the data maintained by the battery.*

To replace the battery, follow the procedure listed below:

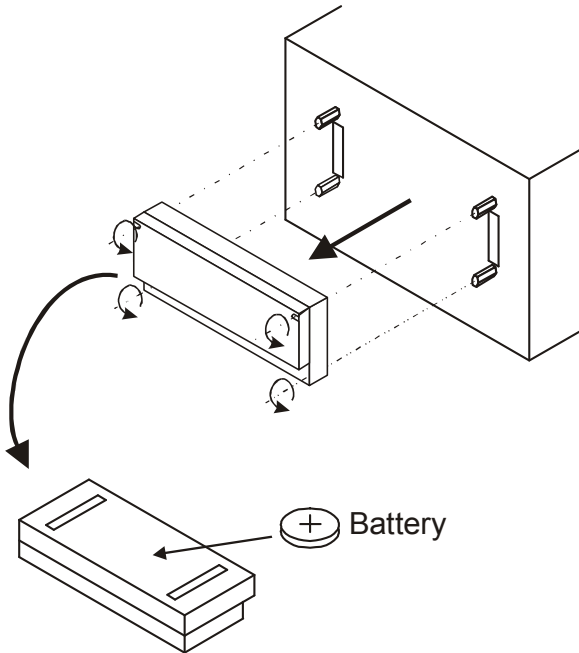

Figure 42 - battery replacement

- 1) turn off the power to the panel
- 2) use a screwdriver to loose the four screws securing the block composed by the two metal units
- 3) remove the block
- 4) remove the battery
- 5) replace the battery with a new one

**Note: CAUTION!** *Danger of explosion if battery is incorrectly replaced. Replace only with the same or equivalent type recommended by the manufacturer. Dispose of used batteries according to the manufacturer's instructions.*

- 6) replace the block; tighten the four screws
- 7) apply power to the panel and check that battery good status is signaled.

**Note:** *Dispose of batteries according to local regulations.*



## Removing the Legends

The keyboard legends can be removed in one step by grasping the exposed portion of the legend and sliding it downward.

Use the blank legends that come with the panel or other with equivalent thickness and consistency. Do not use legends thicker than ones included in the panel.

**Dedicated LED's**

The table below shows the name and the symbol (when available) of the LED's dedicated to special functions which may be available in the UniOP operator panels.





| LED   |       | Status | Meaning                                    |
|---|-------|--------|--|
| Name/symbol   | Color |        |  |
| FAULT/FLT   | red   | OFF    | No hardware problem detected; battery OK   |
|   |       | BLINK  | Battery low                                |
|   |       | ON     | Hardware fault                             |
| DL  | green | OFF    | No keys are pressed and no errors          |
|   |       | BLINK  | Communication error (not all models)       |
|   |       | ON     | While any key is pressed (visual feedback) |
|            | red   | OFF    | No hardware problem detected               |
|   |       | BLINK  | Battery low                                |
|   |       | ON     | Hardware fault                             |
|   | green | OFF    | No keys are pressed                        |
|   |       | ON     | While any key is pressed (visual feedback) |
| RUN /    | green | OFF    | Hardware fault                             |
|   |       | ON     | Unit in operation                          |
| COM /    | green | BLINK  | Communication error                        |
|   |       | ON     | Communication OK                           |
| ALARM /  | red   | OFF    | No alarms                                  |
|   |       | BLINK  | Alarm requires acknowledgment              |
|   |       | ON     | Alarm active                               |

Table 2 - Dedicated LED's

## Usage and Safety Guidelines

### Applicable Regulations

Regulations and recommendations have been issued in Europe covering the main safety-related issues in control systems which include operator interfaces.

EN 60204-1 lists some important guidelines applicable when using operator interfaces.

- 9.2.4 Suspension of safeguards
- 9.2.5.3 Stop
- 9.2.5.4 Emergency stop
- 9.2.5.6 Hold-to-run controls
- 9.2.5.7 Two-hand controls
- 9.4 Control function in case of failure

Do not use operator interface to directly command motors, valves or other actuators not equipped with safeguards and potentially harmful to persons or equipment in case of fault to the unit.

The units are intended to be mounted on the front panel of a metallic cabinet. The service personnel, when operating directly on the powered unit, must be electrostatically discharged.

All safety related regulations must be observed

**CAUTION!** *Don't open the panel rear cover when the power supply is applied.*

### Installation Environment

The equipment is not intended for continuous exposure to direct sunlight. This might accelerate the aging process of the front panel film.

The equipment is not intended for installation in contact with corrosive chemical compounds. Check the resistance of the front panel film to a specific compound before installation.

Do not use tools of any kind (screwdrivers, etc.) to operate the keyboard of the panel or the touch screen.

In order to meet the front panel protection classifications, proper installation procedure must be followed:

- the borders of the cutout must be flat
- screw up each fixing screw until the plastic bezel corner get in contact with the panel.
- The cutout for the panel must be of the dimensions indicated in this manual.
- Two types of gaskets are delivered with the UniOP panels, depending on the model, rectangular or linear.

**Applying the rectangular gasket**

- The gasket should be applied around the cutout prepared for the panel being careful not to place it under tension
- The gasket should be replaced every time that the panel is dismounted and remounted in its place

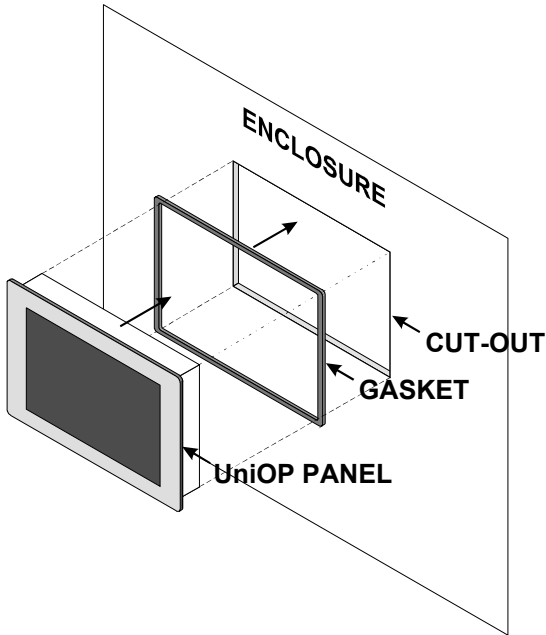

Figure 43 - panel with rectangular gasket installation

**Applying the two linear gaskets:**

Thin strip:

- The gasket should be applied around the cutout prepared for the panel
- The gasket should be applied starting from the middle of the lower side being careful not to place it under tension
- The two ends of the gasket should meet without overlap
- The gasket should be replaced every time that the panel is dismantled and remounted in its place

Large strip:

- The gasket should be applied on the operator panel just behind the bezel
- The gasket should be applied starting from the 1/3 of the lower side being careful not to place it under tension
- The two ends of the gasket should meet without overlap
- The gasket should be replaced every time that the panel is dismantled and remounted in its place

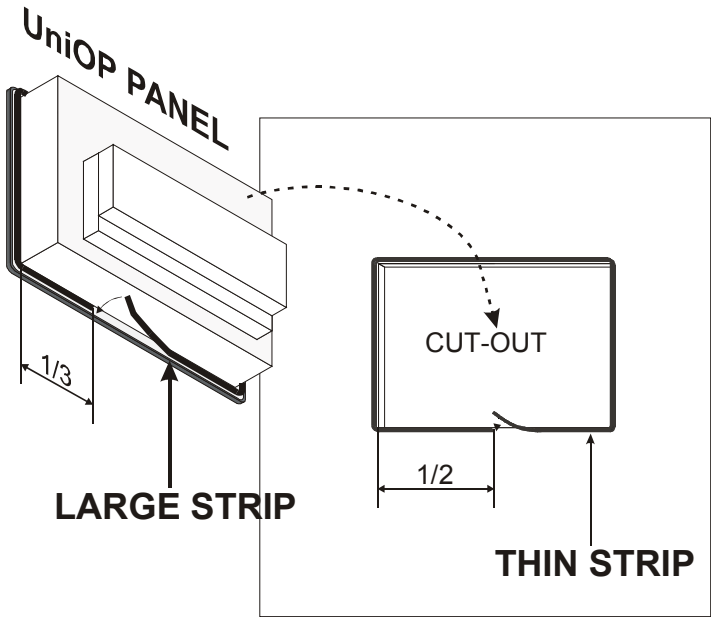

Figure 44 - panel with linear gaskets installation

## Installation Procedures

Place the four fixing brackets on the longer side near the corners, as shown in figure (Figure 48). Screw each fixing screw until the plastic or aluminium bezel corner get in contact with the panel.

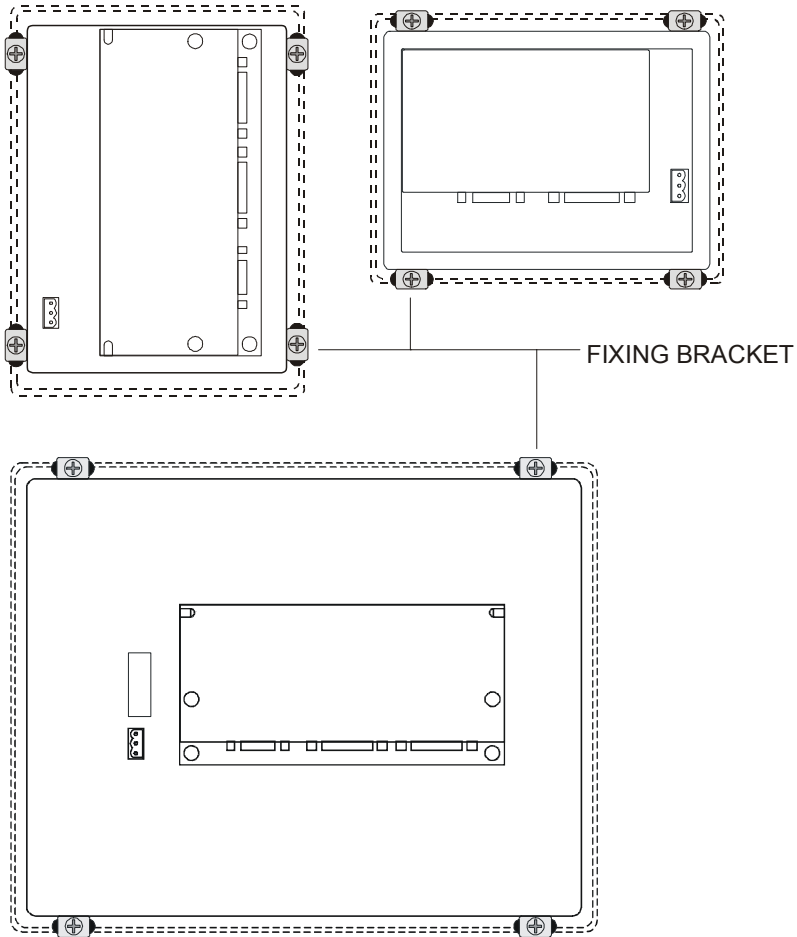

Figure 45 – Fixing bracket position



## Cleaning Faceplates

The equipment must be cleaned only with a soft cloth and neutral soap product. Do not use solvents.

## Handling the Memory Cards

The SSFDC memory cards used in some of the UniOP operator panels need to be handled with care when replaced in the memory slot of the panel.

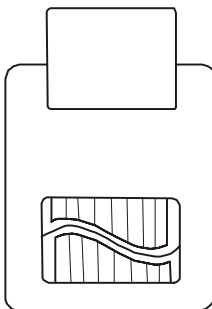

Figure 46 – SSFDC memory card

Before inserting the memory card in its slot in the panel, the contact area must be verified to be clean. Any track of contaminants such as oil or any greasy substances should be carefully removed.

Contamination on the golden contacts of the memory card, at the moment the media is inserted in the slot, may generate an insulating layer that may result in electrical contact problems with the sliding elements of the socket.

Corrosive / active chemicals may permanently damage the memory card golden surface. Any contact with such substances must be carefully avoided.

To ensure the proper operation of the memory media the contact surface of the SSFDC card should be cleaned with a soft, clean tissue.

**Note:** *The use of any synthetic cloth could permanently damage the memory card due to electrostatic discharge.*

Direct contact with the human body (fingers) with the contact area should be carefully avoided.

In case the memory card needs to be removed from the slot and carried around, it has to be kept in a special antistatic protective case.

### Getting Started

UniOP panels must be programmed with the programming package Designer.

To program a panel you will have to connect the panel to a personal computer running Designer software package; the panel must be in Configuration mode to be programmed. Use the cable CA2/CA114 to connect the panel to a personal computer.

The software package Designer is a Windows<sup>TM</sup> application and must be properly installed. The Windows<sup>TM</sup> environment is not included in the software package Designer and must already be installed on the personal computer.

The software package can use either the communication ports COM1 or COM2 on the personal computer. Check that the Designer program is correctly configured to communicate with the communication port to which the cable attached.

The communication parameters between the panel and the personal computer are:

|           |   |
|-----------|---|
| speed:    | 9600 (models PC/Printer Port support also speeds of<br>19200 and 38400 baud ) |
| parity:   | none  |
| stop bit: | 1   |

The Designer software defaults to the correct parameters.

The version of the Designer being used must be compatible with the firmware version of the panel to be programmed. Call for more information on compatibility between firmware and programming software.

## Command Summary

The chapter describes the keyboard commands recognized by UniOP panels. Commands are classified according to the operating modes of the unit.

*Note: The standard command assignment is described in this chapter. All the commands, except those defined for Configuration Mode, can be charged, deleted and/or extended using the Keyboard Macro Editor facility of the programming software.*

Some models do not have CLEAR key on the keyboard; the corresponding function can be done pressing the keys ← e → at the same time.

Some models are designed to be attached to an external keyboard of type ET-F or AT-F; the commands described in this chapter are generally referring to the use of an external keyboard

All the UniOP models, have at least 4 arrow keys and the Enter key. Panels with touch screen will show system defined touch keys on the screen whenever it is required (Figure 50).



Figure 47 - Default touch keys for the panels with touchscreen

Some of the keys described in this chapter may not be available in each UniOP model. The functions associated to them may, however, be implemented using the Keyboard Macro Editor or using an alternative predefined key.

Models without numeric keypad and without touch screen allow numeric data entry using arrow keys and/or using the Keyboard Macro Editor.



Touch screen panels will show automatically a numeric keypad whenever the data entry phase is activated.

*Note: the text '2 s' associated to a key means that the key has to be held for two seconds to activate the associated function.*

## Configuration Mode

- ENTER shows the type and version of the communication driver stored in the unit (if any)
- ENTER 2 s returns to Operation Mode if a valid communication driver and a valid project are stored in the unit (the key must be pressed for 2 seconds)

## Operation Mode

- ↑ scroll page up
- ↓ scroll page down
- ← previous page
- next page
- ENTER 2 s recall the Command Menu
- 0/INS enter Data Entry Mode
- Ins enter Data Entry Mode
- 9/PRN print page/cancel print
- Prt Scr print page/cancel print
- ENABLE 2 s recall Direct Access Mode
- 6/  (2) recall Password Insert Mode
- 3/  (2) recall Date/Time Insert Mode

## Command Menu

- ↑ select up
- ↓ select down
- ← select left
- select right
- ENTER activate selection
- CLEAR <sup>(1)</sup> return to Page Mode

## System Menu

- ↑ select up
- ↓ select down
- ← activate selection
- activate selection
- ENTER return to Page Mode when EXT is selected
- CLEAR <sup>(1)</sup> return to Page Mode

## Data Entry Mode

When in Data Entry Mode the meaning of the keys changes depending on whether a field has been selected for Data Entry or not. A field is selected when the Data Entry procedure has been started on that field. If not field has already been selected for Data Entry, the key assignment is shown in the table below.

|                      |   |
|----------------------|---|
| ↑                    | move to field in previous row                                       |
| ↓                    | move to field in next row   |
| ←                    | previous field  |
| →                    | next field  |
| Ins                  | next field  |
| 0÷9 . +/-            | select field a numeric field for Data Entry and enter numeric value |
| ENTER                | select a field for Data Entry                                       |
| CLEAR <sup>(1)</sup> | cancel entry and return to Page Mode                                |

After a field has been selected for Data Entry, the keys are interpreted as follows.

|                      |   |
|----------------------|---|
| ↑                    | increment digit / scroll up ASCII / select message up     |
| ↓                    | increment digit / scroll down ASCII / select message down |
| ←                    | move cursor left in ASCII field                           |
| →                    | move cursor right in ASCII field                          |
| 0÷9 . +/-            | numeric entry   |
| ENTER                | confirm entry and return to Page Mode                     |
| CLEAR <sup>(1)</sup> | cancel entry and return to Page Mode                      |



## Alarm Mode

|                      |                                  |
|----------------------|----------------------------------|
| ↑                    | previous alarm in the list       |
| ↓                    | next alarm in the list           |
| ENTER 2 s            | acknowledge current alarm        |
| CLEAR <sup>(1)</sup> | return to page Mode              |
| 9/PRN                | alarm list printout/cancel print |
| Prt Alm              | alarm list printout/cancel print |
| Prt Scr              | alarm list printout/cancel print |



## Event Mode

|                      |                                  |
|----------------------|----------------------------------|
| ↑                    | scroll up                        |
| ↓                    | scroll down                      |
| CLEAR <sup>(1)</sup> | return to page Mode              |
| 9/PRN                | event list printout/cancel print |
| Prt Alm              | event list printout/cancel print |
| Prt Scr              | event list printout/cancel print |



## Password Entry Mode

|   |  |
|---|--|
|  | increment digit                          |
|  | decrement digit                          |
|  | next digit                               |
| 0÷9   | numeric password entry                   |
| ENTER   | confirm password and return to Page Mode |
| CLEAR <sup>(1)</sup>  | cancel entry and return to Page Mode     |
| ESC   | end entry and return to Page Mode        |



## Time and Date Set Mode

|   |                       |
|---|-----------------------|
|  | increment field value |
|  | decrement field value |
| ENTER   | field select          |
| CLEAR <sup>(1)</sup>  | return to Page Mode   |

## Direct Page Selection Mode

|   |                                       |
|---|---------------------------------------|
|  | decrement page                        |
|  | increment page                        |
| 0÷9   | page number entry                     |
| ENTER   | confirm entry and go to selected page |
| CLEAR <sup>(1)</sup>  | cancel entry and return to Page Mode  |

## Direct Acces Mode

|   |   |
|---|---|
|  | decrement offset                                    |
|  | increment offset                                    |
| 0÷9   | numeric offset entry                                |
| ENTER   | select next, confirm offset entry                   |
| CLEAR <sup>(1)</sup>  | cancel numeric offset entry end return to Page Mode |
| T   | select timers                                       |
| Z   | select counters                                     |
| E   | select digital inputs                               |
| A   | select digital outputs                              |
| M   | select flags/merkers                                |
| ENABLE  | return to Page Mode                                 |

Notes:

- (1) it is equivalent to the key ESC/  , when available
- (2) available only in the models BKDR-16, CP10G-04 and MKDG-06.

## Troubleshooting

In the case it might be impossible to switch the operator panel to Configuration Mode due to problems in the start-up phase, follow the procedure described below:

1. Switch off the unit
2. Press and hold any 3 keys
3. Turn on the unit and hold the keys pressed until Configuration Mode will be shown on the screen.

## Touchscreen Calibration

Standard calibration:

1. Recall Configuration Mode
2. Touch the CLEAR key on the screen until a small round symbol will appear on the top right corner of the screen
3. touch and hold the symbol until it will move to the low left corner of the screen
4. touch and hold the symbol until the indication to touch the ← key will be displayed on the screen
5. touch and hold the key ← until the indication to touch the ↓ key will be displayed on the screen
6. touch and hold the key ↓ until the indication to touch the Enter key will be displayed on the screen
7. touch and hold the Enter key until the panel will switch to Operation Mode (if a valid project is loaded in the memory)

Emergency calibration.

The Emergency calibration procedure should be used in all cases when it would result not possible to go to calibration using the standard procedure.

1. Switch of the unit
2. turn on the unit
3. tap in the middle of the touchscreen with a frequency of about one second until the operator panel will enter the Calibration Mode
4. perform the standard calibration procedure.