

# PP520 LED Lighting Controllers

Issue 018



**User manual**

## Copyright and disclaimer notice

Except as prohibited by law:

All hardware, software and documentation is provided on an 'as is' basis. This information is for guidance only. Installers must perform their own risk assessment specific to each installation.

It is essential that the user ensures that the operation of the product is suitable for their application.

The user must ensure that incorrect functioning of this equipment cannot cause any dangerous situation or significant financial loss to occur.

Deliberate acts of endangerment and vandalism are not covered by this document and must be considered by the installer.

While care has been taken in the preparation of this document Gardasoft Vision Ltd will not accept any liability for consequential loss of any kind except those required by law.

All trademarks acknowledged. Hardware, software and documentation are Copyright 2002 – 2017 Gardasoft Vision Ltd.

## EC conformity declaration

The EC Certificate of Conformity is available from Gardasoft Vision Ltd on request

Issue status of this document: Issue 018 (April 2017)

---

## Contents

<b>1</b>	<b>Getting started</b>	<b>5</b>
<b>2</b>	<b>Safety</b>	<b>6</b>
2.1	Heat	6
2.2	Electrical	6
2.3	General	7
2.4	Installation guidance (disclaimer)	7
<b>3</b>	<b>Sicherheit</b>	<b>8</b>
3.1	Wärme	8
3.2	Elektrik	8
3.3	Allgemein	10
3.4	Installationsanleitung (Haftungsausschluss)	10
<b>4</b>	<b>Sécurité</b>	<b>11</b>
4.1	Chaleur	11
4.2	Électricité	11
4.3	Généralités	12
4.4	Guide d'installation (clause de non-responsabilité)	13
<b>5</b>	<b>General description</b>	<b>14</b>
5.1	Output modes	14
5.1.1	<i>Continuous</i>	14
5.1.2	<i>Pulsed</i>	14
5.1.3	<i>Switched</i>	15
5.2	Triggers	15
5.3	Flags	15
5.4	Automatic light sensing	15
5.5	Cold start	16
<b>6</b>	<b>Mechanical fixing</b>	<b>17</b>
<b>7</b>	<b>PP520 heat output</b>	<b>19</b>
7.1	Heat output per channel	19
7.2	Total heat output	20
<b>8</b>	<b>Connections</b>	<b>21</b>
8.1	Triggers	22
8.2	Ethernet	22
8.3	Wiring	22
8.4	Power supply	22
<b>9</b>	<b>Front panel configuration</b>	<b>23</b>
9.1	Startup	23
9.2	Setting the light rating	23
9.3	Setting up continuous output	24
9.4	Setting up switched output	25
9.5	Setting up pulsed operation	26
9.6	Setting pulse delay and width times	28
<b>10</b>	<b>Ethernet communication</b>	<b>31</b>
10.1	Connection	31
10.2	IP address	31
10.2.1	<i>DHCP</i>	32
10.2.2	<i>Fixed IP address</i>	32

10.3	Front panel Ethernet set up	32
10.4	Reading an IP address	35
<b>11</b>	<b>Webpage configuration</b>	<b>37</b>
11.1	Main page	37
11.2	Configuration page	38
11.3	General setup page	39
<b>12</b>	<b>Command configuration</b>	<b>40</b>
12.1	Command structure	40
12.2	Lighting commands	43
12.3	Command summary	45
<b>13</b>	<b>Reference information</b>	<b>47</b>
13.1	Timings	47
13.2	Specifications	47
13.3	Error codes	48

---

# 1 Getting started

This user manual describes the setting up and operation of the PP520 lighting controllers.

The PP520 is a two channel lighting controller that provides 2 Amps continuously or 10 Amps pulsed. The controller is also available in a fast pulsing variant that is identified by the 'F' suffix (refer to [Section 13, Reference information](#)).

Read [Section 2, Safety](#) (or [Section 3, Sicherheit](#), or [Section 4, Sécurité](#)) and [Section 13, Reference information](#), and check the PP520 fulfils your requirements.

Mount the PP520 as described in [Section 6, Mechanical fixing](#), using a DIN rail or the mounting holes. In particular, read the notes on heatsinking in [Section 7, PP520 heat output](#).

Connect the PP520 up to a supply and an LED lighting unit as described in [Section 8, Connections](#). When the PP520 powers up, it should show two alternating lines on the display to indicate that it is operating properly.

To configure the PP520, refer to [Section 9, Front panel configuration](#) to set it up from its front panel or [Section 11, Webpage configuration](#) to use the PP520's web pages. The commands that may be used with the Ethernet connection are described in [Section 12, Command configuration](#).

For additional information on the use of the PP520. Visit [www.gardasoft.com](http://www.gardasoft.com) to download a range of Application Notes.

## 2 Safety

Read this before using the PP520. Always observe the following safety precautions. If in doubt, contact your distributor or Gardasoft Vision. The following symbols mean:



**Warning:** Read instructions to understand possible hazard



**Warning:** Surface may get hot.



**Warning:** Possible hazardous voltage.

Where these symbols appear in the manual, refer to the text for precautions to be taken.

### 2.1 Heat



Ensure the PP520 is mounted correctly (see [Section 6, Mechanical fixing](#)), and that you do not exceed any of the ratings for the unit (see [Section 13, Reference information](#)).

At its maximum ratings, the PP520's enclosure can exceed 75°C which is sufficient to cause a burn if touched. Place in a position where personnel cannot accidentally touch it and ensure there is a free flow of air around the unit.

### 2.2 Electrical



The PP520 produces high energy pulses. Take care to connect the outputs correctly and protect the output wiring and load from any short circuits. When switched off, energy remains stored in the PP520 for about 15 seconds.

The PP520 does not have complete tracking isolation of inputs and outputs, therefore, please observe the following guidance:

- Computer equipment that is connected to the communication or trigger ports must be internally powered or separated from mains electricity by double insulation/reinforced isolation or be approved to IEC 60950-1 standard. All other equipment connected to the triggers or other ports must also have double insulation/reinforced isolation protection from the mains supply.
- The Power Supply Unit (PSU) used to energise the PP520 must provide double insulation/reinforced isolation from mains electricity and protected against short circuits and overloads. We recommend using a PSU that limits its output current to the appropriate rating of the controller by design, by setting the current limit on the supply (if possible), or through over current protection. The PSU should be approved to either IEC 60950-1, IEC

60335-1, IEC 61010-1, IEC61558-1,-2,-16. The PSU may also be approved to equivalent or superior safety standards.

- Any energised conductors derived from mains electricity must also have Safety Extra Low Voltage (SELV) output. Refer to [Section 13, Reference information](#) for allowable voltage limits.
- At maximum ratings the temperature of the enclosure can exceed 75°C. Therefore, either all cabling must be rated to at least 100°C, or all cabling must be additionally insulated by an appropriately rated heat resistant sleeve or prevented from touching the metal enclosure of the controller, or its heatsink where fitted.
- Power supply cabling to the controller must be rated to at least 4A.
- The cabling from the channel output to the load must be rated higher than the maximum channel output current.
- If the controller is setup incorrectly, or in the event of failure, the energy provided by the power supply to the controller may become directly connected to any or all output channels. You must consider this during installation, and if necessary, provide adequate protection.
- The DC power supply to controller must be externally fused to 4A using a slow blow fuse (T4AH, 50V).
- The installer must provide a clearly marked, nearby and easily accessible switch as part of the installation to allow the controller to be disconnected from its energy source on both power conductors.
- Transients caused by inductive loads must be suppressed externally to the PP520.

**Warning:** This is a Class A product. Its use in residential areas may cause radio interference, and such use should be avoided unless special measures are taken by the user to restrict emissions to a level that allows the reception of broadcast transmissions.

## 2.3 General



The PP520 must not be used in an application where its failure could cause a danger to personal health or damage to other equipment.

If the equipment is used in a manner not specified by the manufacturer, the protection provided by the equipment may be impaired.

## 2.4 Installation guidance (disclaimer)

This information is for guidance only. Installers must perform their own risk assessment specific to each installation. While Gardasoft Vision Ltd has taken every care in the preparation of this advice, Gardasoft Vision Ltd and Gardasoft LLC accept no liability for damages of any kind except those required by law. Deliberate acts of endangerment and vandalism are not covered by this document and must be considered by the installer.

## 3 Sicherheit

Bitte lesen Sie vor Verwendung des PP520 diese Informationen. Beachten Sie immer die folgenden Sicherheitshinweise. Wenden Sie sich im Zweifelsfall an Ihren Händler oder Gardasoft Vision. Die folgenden Symbole haben die folgende Bedeutung:



**Warnung:** Lesen Sie die Hinweise, um eine mögliche Gefahr zu verstehen.



**Warnung:** Oberfläche kann heiß werden.



**Warnung:** Mögliche gefährliche Spannung.

Wenn diese Symbole in der Anleitung auftauchen, enthält der Text Hinweise zu den zu ergreifenden Vorsichtsmaßnahmen.

### 3.1 Wärme



Stellen Sie sicher, dass der PP520 korrekt montiert ist (siehe [Section 6, Mechanical fixing](#)) und dass Sie die Grenzwerte für das Gerät nicht überschreiten (siehe [Section 13, Reference information](#)).

Bei den maximalen Grenzwerten kann das Gehäuse des PP520 75°C überschreiten, was ausreichend ist um bei einer Berührung zu Verbrennungen zu führen. Positionieren Sie das Gerät so, dass eine versehentliche Berührung durch das Personal ausgeschlossen ist und stellen Sie sicher, dass Luft frei um das Gerät zirkulieren kann.

### 3.2 Elektrik



Das PP520 erzeugt Impulse mit hoher Energie. Achten Sie darauf, die Ausgänge korrekt anzuschließen und schützen Sie die Ausgangsverkabelung und Last gegen Kurzschlüsse. Beim Ausschalten bleibt Energie für etwa 15 Sekunden im PP520 gespeichert.

Das PP520 verfügt über keine vollständige Nachlaufisolierung der Eingänge (einschließlich Trigger- und Kommunikationsports) und Ausgänge. Beachten Sie daher unbedingt die folgenden Hinweise:

- Computergeräte, die an die Kommunikations- oder Trigger-Ports angeschlossen sind, müssen über eine interne Stromversorgung verfügen oder vom Stromnetz durch eine doppelte Isolierung/verstärkte Isolierung getrennt sein oder nach dem Standard IEC 60950-1 zugelassen sein. Alle anderen Geräte, die an die Trigger- oder andere Ports angeschlossen sind, müssen ebenfalls durch eine doppelte Isolierung/verstärkte Isolierung vom Stromnetz getrennt sein.
- Das Netzgerät, das zur Stromversorgung des PP520 dient, muss durch eine doppelte Isolierung/verstärkte Isolierung von der Stromversorgung



getrennt sein und gegen Kurzschlüsse und Überlastungen geschützt sein. Wir empfehlen die Verwendung eines Netzgeräts, das den Ausgangsstrom durch konstruktive Maßnahmen, durch Einstellen der Stromgrenze an der Versorgung (wenn möglich) oder durch einen Überstromschutz auf den geeigneten Nennstrom der Steuerung begrenzt. Das Netzgerät muss nach IEC 60950-1, IEC 60335-1, IEC 61010-1 oder IEC61558-1,-2,-16 zugelassen sein. Das Netzgerät kann auch nach gleichwertigen oder höheren Standards zugelassen sein.

- Alle stromführenden Leiter, die vom Stromnetz abgeleitet sind, müssen ebenfalls Sicherheitskleinspannung (SELV) am Ausgang erzeugen. Hinweise zu den zulässigen Spannungsgrenzwerten finden Sie im [Section 13, Reference information](#).
- Bei den maximalen Grenzwerten kann die Temperatur des Gehäuses 75°C überschreiten. Daher muss entweder die gesamte Verkabelung für mindestens 100°C bemessen sein oder die gesamte Verkabelung muss zusätzlich mit einer angemessen dimensionierten wärmebeständigen Tülle isoliert sein oder gegen Kontakt mit dem Metallgehäuse der Steuerung oder deren Kühlkörper, sofern angebracht, geschützt sein.
- Die Verkabelung der Stromversorgung zur Steuerung muss für mindestens 4A bemessen sein.
- Die Verkabelung vom Kanalausgang zur Last muss höher als der maximale Kanalausgangsstrom dimensioniert sein.
- Wenn die Steuerung falsch eingerichtet ist oder im Fall eines Fehlers, kann es vorkommen, dass die von der Stromversorgung an die Steuerung abgegebene Energie direkt mit einem oder allen Ausgangskanälen verbunden wird. Sie müssen dies bei der Installation berücksichtigen und gegebenenfalls für einen geeigneten Schutz sorgen.
- Die Gleichstromversorgung der Steuerung muss extern durch eine träge Sicherung (T4AH, 50V) bis 4A gesichert sein.
- Der Installationstechniker muss einen deutlich gekennzeichneten, leicht zugänglichen Schalter als Teil der Installation in der Nähe vorsehen, mit dem die Steuerung an beiden Stromleitern von ihrer Stromquelle getrennt werden kann.
- Durch induktive Lasten verursachte Einschaltstöße zum PP520 müssen extern unterdrückt werden.

**Warnung:** Es handelt sich hierbei um ein Produkt der Klasse A. Die Verwendung in Wohngebieten kann zu Funkstörungen führen und eine solche Verwendung sollte vermieden werden, es sei denn besondere Maßnahmen werden vom Anwender ergriffen, um die Emissionen auf ein Niveau zu begrenzen, das den Empfang von Rundfunkübertragungen ermöglicht.

### 3.3 Allgemein



Das PP520 darf nicht in Anwendungen eingesetzt werden, bei denen es durch einen Ausfall des Geräts zu einer Gefahr für die Gesundheit von Personen oder zur Beschädigung anderer Geräte kommen könnte.

Wenn das Gerät in einer anderen als der vom Hersteller vorgesehenen Weise verwendet wird, kann die Schutzvorrichtung des Geräts beeinträchtigt werden.

### 3.4 Installationsanleitung (Haftungsausschluss)

Diese Informationen dienen nur zur Orientierung. Installationstechniker müssen ihre eigene spezifische Risikobewertung für die jeweilige Installation durchführen. Auch wenn Gardasoft Vision Ltd diese Empfehlung mit größter Sorgfalt erstellt hat, übernehmen Gardasoft Vision Ltd und Gardasoft LLC keine Haftung für Schäden jeglicher Art, außer in dem gesetzlich erforderlichen Maße. Vorsätzliche Gefährdungs- oder Zerstörungshandlungen werden in diesem Dokument nicht behandelt und müssen vom Installationstechniker berücksichtigt werden.

## 4 Sécurité

Lisez ce document avant d'utiliser le PP520. Respectez les mesures de sécurité suivantes en toutes circonstances. En cas de doute, contactez votre distributeur ou Gardasoft Vision. Les symboles ci-dessous auront la signification suivante:



**Attention:** Lisez les instructions pour comprendre quels sont les risques éventuels.



**Attention:** La surface peut devenir chaude.



**Attention:** Risque d'électrocution.

Lorsque ces symboles apparaissent dans le manuel, reportez-vous aux consignes pour connaître les précautions à prendre.

### 4.1 Chaleur



Veillez à ce que le PP520 soit monté correctement (voir [Section 6, Mechanical fixing](#)) et à ne dépasser aucune valeur nominale pour l'unité (voir [Section 13, Reference information](#)).

Lorsqu'il atteint ses valeurs nominales maximales, le boîtier PP520 peut dépasser les 75°C, ce qui est suffisant pour provoquer des brûlures en cas de contact. Placez l'appareil à un endroit où le personnel ne risque pas de le toucher par accident et veillez à ce que l'air circule librement autour de l'unité.

### 4.2 Électricité



Le PP520 produit des impulsions d'énergie élevées. Veillez à bien raccorder les sorties et à ce que les câbles de sortie et la charge soient à l'abri de tout court-circuit. Lorsque le PP520 est éteint, de l'énergie résiduelle reste dans l'appareil pendant environ 15 secondes.

Le PP520 ne possède pas de système d'isolation complet des entrées (notamment des ports de déclenchement et de communication) et des sorties. Par conséquent, respectez les consignes suivantes :

- L'équipement informatique connecté aux ports de communication et de déclenchement doit être alimenté en interne ou séparé de l'alimentation secteur par une isolation double/renforcée, ou être approuvé selon la norme CEI 60950-1. Tous les autres équipements branchés aux déclencheurs ou à d'autres ports doivent aussi posséder une isolation double/renforcée pour être protégés de l'alimentation secteur.
- Le boîtier d'alimentation utilisé pour mettre sous tension le PP520 doit fournir une isolation double/renforcée pour isoler le PP520 de l'alimentation secteur, et le protéger des courts-circuits et des

surcharges. Nous recommandons d'utiliser un boîtier d'alimentation qui limite le courant de sortie de l'appareil à la valeur nominale appropriée du contrôleur, en réglant la limite de courant sur l'alimentation (si possible) ou via la protection contre les surcharges. Le boîtier d'alimentation doit être approuvé selon la norme CEI 60950-1, CEI 60335-1, CEI 61010-1 ou CEI 61558-1,-2,-16. Le boîtier d'alimentation peut aussi être approuvé selon des normes de sécurité équivalentes ou supérieures.

- Tous les conducteurs sous tension dérivés depuis l'alimentation secteur doivent aussi posséder une sortie à tension de sécurité extra-basse. Se reporter à la [Section 13, Reference information](#) pour les limites de tension autorisées.
- Lorsqu'il atteint ses valeurs nominales maximales, le boîtier du PP520 peut dépasser les 75°C. Par conséquent, tout le câblage doit soit avoir une capacité minimale de 100°C, soit être en plus isolé par une gaine suffisamment résistante à la chaleur, soit ne pas toucher le boîtier en métal du contrôleur ou son dissipateur thermique s'il est installé.
- Le câblage d'alimentation vers le contrôleur doit avoir une capacité minimale de 4A.
- Le câblage reliant la sortie de la chaîne à la charge doit avoir une capacité supérieure au courant de sortie maximal de la chaîne.
- Si le contrôleur est mal réglé ou en cas de panne, l'énergie fournie par l'alimentation au contrôleur peut devenir directement connectée à n'importe quelle chaîne de sortie ou à toutes les chaînes de sortie. Vous devez prendre en compte ce paramètre durant l'installation et si nécessaire, fournir une protection adéquate.
- L'alimentation en courant continu vers le contrôleur doit être protégée par un fusible 4A en externe, plus précisément un fusible à action retardée (T4AH, 50V).
- Dans le cadre de l'installation, l'installateur doit fournir un interrupteur clairement marqué, qui soit à proximité et facilement accessible, pour permettre au contrôleur d'être déconnecté de sa source d'énergie sur les conducteurs d'alimentation.
- Les coupures causées par des charges inductives doivent être supprimées de manière externe vers le PP520.

**Attention:** Il s'agit d'un produit de classe A. Son utilisation en zone résidentielle peut causer des interférences radio. Ce type d'utilisation doit être évité, sauf si des mesures particulières sont prises par l'utilisateur pour restreindre les émissions à un niveau qui permet la réception des transmissions diffusées.

### 4.3 Généralités



Le PP520 ne doit pas être utilisé dans une application où la santé des personnes et l'intégrité des équipements seraient mises en danger s'il venait à tomber en panne.

Si l'équipement est utilisé autrement qu'aux fins prévues par le fabricant, la protection offerte par l'équipement pourrait en être altérée.

#### **4.4 Guide d'installation (clause de non-responsabilité)**

Ces informations sont seulement à titre indicatif. Les installateurs doivent effectuer leur propre évaluation des risques, pour chaque installation. Même si Gardasoft Vision Ltd a préparé minutieusement ces conseils, Gardasoft Vision Ltd et Gardasoft LLC décline toute responsabilité pour tout dommage, quel qu'il soit, à l'exception de ceux requis par la loi. La mise en péril volontaire ainsi que les actes de vandalisme ne sont pas couverts par le présent document et doivent être pris en compte par l'installateur.

## 5 General description

The PP520 current controller provides repeatable intensity control of LED lighting for machine vision applications. It includes the power supply, intensity control, timing and triggering functions required for machine vision systems.

LED lighting needs a constant current supply as small variations in voltage can cause large variations in light output. Currents can be specified in 2.5mA steps to give very fine control of intensity.

You can set the PP520 up using either the buttons on the front panel (see Section 9, Front panel configuration), through its web pages (see Section 11, Webpage configuration), or using Ethernet commands (see Section 12, Command configuration).

Configurations are saved in non-volatile memory so that the PP520 will resume operation after a power cycle.

### 5.1 Output modes

Three modes of operation are provided separately for each channel:

#### 5.1.1 Continuous

In continuous mode the output is a fixed and continuous current. The brightness can be set from 0% to 100%.

#### 5.1.2 Pulsed

In this mode output is pulsed once per trigger. One trigger input is used to trigger the output. The delay, pulse width and light intensity are all configurable. In pulse mode, the brightness can be set up to 999% of its rating, but only for short periods and low duty cycles so the lighting does not overheat and get damaged. The default limits are as follows:

Brightness	Max pulse width PP520	Max pulse width PP520F	Max duty cycle
0 to 100%	999ms	10ms	100%
101% to 200%	30ms	1ms	30%
210% to 300%	10ms	1ms	20%
301% to 500%	2ms	1ms	10%
501% to 999%	1ms	0.5ms	5%

### 5.1.3 Switched

In switched mode, you can use a trigger input to switch the output current on and off. The output is enabled only when the input has a voltage on it.

## 5.2 Triggers

There are two trigger inputs, as summarised in the table below. The sense of these can be either active high or active low depending on how the 'P' flag is set. The 'P' flag inverts the sense of the trigger (see Section 5.3, Flags).

Mode	Trigger input	Output
Continuous	N/A	Output is on.
Switched	Trigger = 0V	Output is off.
	Trigger = 4.5V to 24V	Output is on.
Pulsed	Trigger goes from 0V to 4.5V	Pulse is triggered.
	Trigger goes from 4.5V to 0V	No action.

## 5.3 Flags

Flags can be set on each channel as follows:

**S flag:** This flag enables or disables autosensing (see Section 5.4, Automatic light sensing). When set, the PP520 senses a light connected to it for the first time and will wait for the current rating to be set. If the flag is not set, the PP520 will revert to the last current rating set.

**E flag:** This flag enables or disables error checking. If the flag is not set the PP520 will not detect lighting errors.

**P flag:** This flag inverts the trigger sense. In pulse mode with the P flag set, the PP520 triggered on the rising edge of the trigger pulse. If the flag is not set, it triggers on the falling edge. The falling edge may give a slower response time. In switched mode with the P flag set, the output is on when the input is on. Clearing the P flag inverts this operation.

## 5.4 Automatic light sensing

When a channel does not have a light connected, the PP520 continually tries to output a small amount of current. When a light is connected, it flashes for a short time (the light is not damaged by this) until the PP520 detects that it is connected. You will then need to set up the current rating of the light (see Section 9, Front panel configuration).

## 5.5 Cold start

To clear the configuration to the default settings, turn on the PP520 while holding the **SEL** and ▼ buttons for about 5 seconds, until **COL** is displayed. Both channels are set up for 50% intensity and continuous operation.



## 6 Mechanical fixing

The PP520 can be mounted onto a flat surface using the M4 clearance mounting holes in the corners of the base or the M4 threaded holes in the centre, see the diagram below.

**Note:** If you choose to mount the PP520 using the threaded holes, ensure no more than 6mm of thread can be screwed in.

The PP520 should only be mounted either vertically or with its base horizontal. It should be mounted at least 15mm away from the sides of plastic enclosures. Likewise leave a similar space between the PP520 and any parts which could be affected by high temperatures.

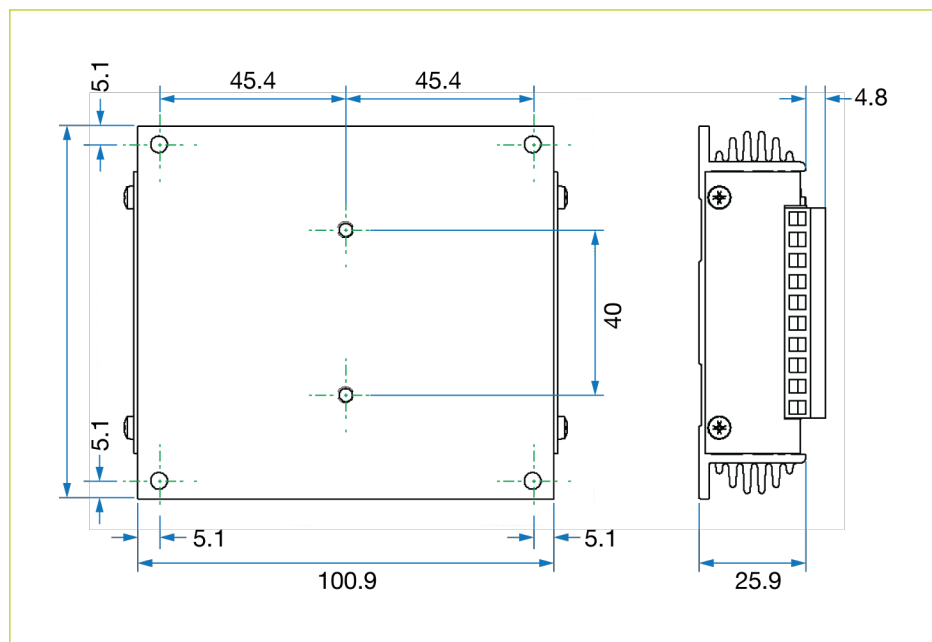

The enclosure of the PP520 is used to dissipate power in the form of heat. For this reason the material to which the unit is attached must be suitable, preferably metallic with ability to dissipate the produced heat. This is particularly important if the power dissipation of the PP520 (as defined by  $P_D$  in Section 13, Reference information) exceeds 8 Watts.

The PP701 kit is available for mounting the PP520 on a DIN rail.

The PP520 does not have an IP rating and should be mounted so that moisture and dirt cannot enter the unit.



To avoid a fire hazard, consider the implications of overheating in the unlikely event of a fault in the PP520. The power dissipation in a fault condition is approximately given by the sum of the following for the two channels:

$$(V_{PS}-V_L) \times I_{PS}$$

Where:  $V_{PS}$  = Power supply voltage

$V_L$  = Rated voltage for lighting

$I_{PS}$  = Maximum current delivered by the power supply.

Either limit the power supply output current(s) so that not more than 30W can be dissipated in the PP520, or mount the unit in an enclosure.

For further information about heat output from the PP520, refer to [Section 7, PP520 heat output](#).

To limit the power, set the power supply output voltages to the minimum value required by the LED light and the PP520 together. Choose a PSU that limits its output current by design, by setting the current limit on the supply (if this feature exists) or use fuses. Remember to de-rate the fuse if mounted in an enclosure, as the temperature will be higher than ambient.

An enclosure may also be required for other parts of the system such as power supplies and should provide mechanical and environmental protection in industrial applications.

If an enclosure is used, it should be metal or plastic (with a flammability rating of UL94-V1 or better) and with no holes below or to the sides of the PP520 when mounted. Cable entries below the PP520 should be through glands that also have a flammability rating of UL94-V1 or better. Observe the specified gap between the PP520 and any other part or side of the enclosure.

## 7 PP520 heat output

The PP520 controller has a linear circuit to produce constant current output. This section explains how to calculate the heat output from the PP520 and what measures you can take to manage it.

### 7.1 Heat output per channel

For a continuous output current, the heat output is given by:

$$\text{Heat output} = I_O \times (V_S - V_L)$$

Where:  $I_O$  = Output current set by the user

$V_S$  = Supply voltage across VS1+ and GND  
(for output 1)

$V_L$  = Voltage across the light LD1+ and LD1-  
(for output 1)

This is usually easy to calculate as the voltage across the light is normally the voltage rating of the light as declared in its specification. Alternatively you can measure it using a voltmeter.

For a pulsed output, the heat output is given by:

$$\text{Heat output} = I_O \times \text{duty cycle} \times (V_S - V_L)$$

Where:  $I_O$  = Output current set by the user

$V_S$  = Supply voltage

$V_L$  = Voltage across the light

And duty cycle is defined as:

$$\text{Duty cycle} = W_P \times F_T$$

Where:  $W_P$  = Pulse width in seconds

$F_T$  = Trigger frequency in Hz

When overdriving, the voltage across the light is more difficult to identify. In most cases, you can use the voltage rating of the light.

## 7.2 Total heat output

The total heat output from the PP520 is given by adding the heat output for both channels as calculated above.

There are several ways to reduce the heat output from the PP520:

- Use pulse mode. If the output is only on when you need it, you can significantly reduce the heat output. Feed the camera trigger into the PP520 and pulse the lights.
- Turn the light off when not needed. If you do not have precise timing of when the camera will trigger, you can use switched mode to switch the output off or on depending on the trigger input (or use the PP520 Ethernet commands to turn the output on and off).
- Reduce the output current if possible.
- Reduce the supply voltage. Most PSUs have some adjustment in their output voltage.
- Connect lights in series instead of parallel. If you have an array of lights or LEDs in parallel, then changing the arrangement to serial will increase the voltage across them but reduce the overall current.
- Use two PP520s and use one channel from each. For high power applications, this may be the easiest solution. Even with one light, it is possible to parallel up two output channels from different PP520s.
- Use a higher power controller from the Gardasoft range, for example a PP820 can dissipate much more heat.

With no heatsinking and no airflow, the PP520 can dissipate the following:

8W at 25°C ambient

4W at 40°C ambient

If the heat output is no greater than 8W, no heatsinking is required. If the heat output is between 8W and 24W, the PP520 needs to be mounted on a solid piece of metal to dissipate the heat. Above 24W, it is necessary to have a large heatsink with fan cooling.

## 8 Connections

All connections to the 520 (except Ethernet) are made on screw terminals at one end of the case (see below).

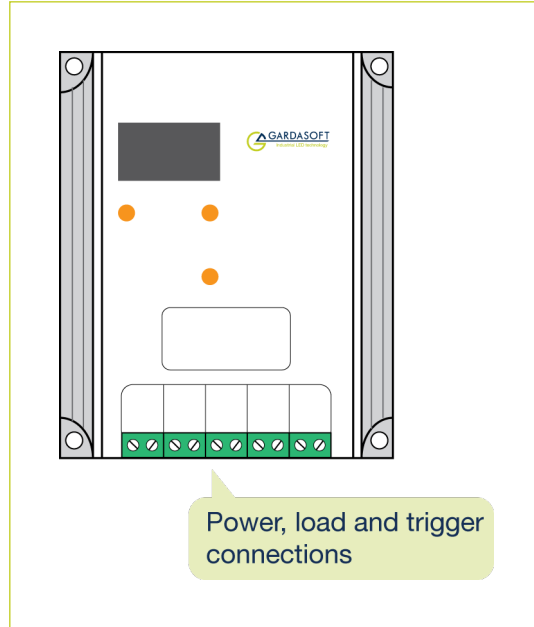

The screw terminals have the following connections:

Screw terminal ID	Function
TRIG1-	Channel 1 trigger input
TRIG1+	
LED1+	Channel 1 lighting output
LED1-	
PSU+	Power supply +
PSU-	Power supply -
LED2-	Channel 2 lighting output
LED2+	
TRIG2+	Channel 2 trigger input
TRIG2-	

## 8.1 Triggers

The PP520 triggers are opto-coupled as shown in the circuit below. A  $V_{TRIG}$  voltage between 4.5V to 24V provides a logic 1 and any  $V_{TRIG}$  voltage below 1V, a logic 0. Typically the value of  $V_F$  is 1.5V.

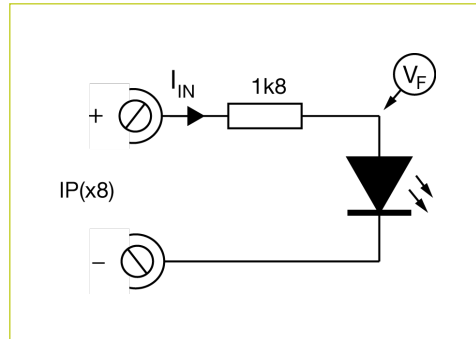

## 8.2 Ethernet

The RJ45 connector fitted to the PP520 requires a straight through cable to connect to a network switch, hub, or router. It runs at 10Mbits per second.

## 8.3 Wiring



Refer to Section 2.2, Electrical (or Section 3.2, Elektrik, or Section 4.2, Électricité) for important guidance on wiring up your PP520.

Ensure that the wire gauge used for these connections is appropriate for the current to be drawn. Ideally, wires should be double crimped or independently secured to ensure they cannot come loose. Route low voltage and mains wiring separately. If they must be loomed together ensure that low voltage insulation rating is sufficient or that supplementary insulation is used.

**Note:** The case of the PP520 is not connected to the GND supply connection.

## 8.4 Power supply



Refer to Section 2.2, Electrical (or Section 3.2, Elektrik, or Section 4.2, Électricité) for important guidance on selecting a power supply for your PP520

Power supplies should be regulated with SELV compliant outputs (fault tolerant). Consideration should be given to fusing. The fuse value can be based on the average current output.

**Note:** In Europe, fuses are designed to pass at their rated current, while in the USA fuses are designed to blow at their rated current.

## 9 Front panel configuration

Using the front panel keypad, you can set the configuration for each channel and set a keylock code so unauthorised users cannot change any settings.

### 9.1 Startup

On power up, the PP520 displays **br** for five seconds followed by **8.8.8** to show that the display is working, then **PP5** and **20** or **20F**, followed by the firmware version (for example **029**). The controller is then ready for operation. To show the unit is operating normally, the LED display shows a pattern of alternating lines.

### 9.2 Setting the light rating

The Autosense feature detects the presence of a light and prompts you to set the rating as follows:



When the PP520 detects a light connected to channel 1 for the first time, **Sn1** is displayed. (A light connected to channel 2 will display **Sn2**).



When the **Cu1** prompt is displayed, press the **SEL** button to set the current rating of the light.



Use the **▲** and **▼** buttons to select the rating of the light in Amps. The current is adjustable in steps of 10mA. Press the **SEL** button when you have set the current.



The PP520 displays a pattern of alternating horizontal bars when the light is operating normally. If you power cycle the controller, it will resume with the same settings.

Other displays are shown for channel 2 connected, and channels 1 and 2 connected.



If an error occurs (if the light is disconnected for example), the PP520 displays **OP**. Press the **SEL** button to cancel this.

### 9.3 Setting up continuous output

Press the **SEL** button for 1 second and follow the steps below:



**CH1** is displayed. Use the ▲ and ▼ buttons to select **CH2** if you wish to set up channel 2. Press the **SEL** button.





Use the **▲** and **▼** buttons to select **SCo** and press the **SEL** button.



**bri** is displayed. Press the **SEL** button.



Use the **▲** and **▼** buttons to set the intensity from 1% to 99.9%, and press the **SEL** button.



Your PP520 is ready to use.

## 9.4 Setting up switched output

Press the **SEL** button for 1 second and follow the steps below:



**CH1** is displayed. Use the **▲** and **▼** buttons to select **CH2** if you wish to set up channel 2. Press the **SEL** button.



Use the **▲** and **▼** buttons to select **SO**n and press the **SEL** button.



**bri** is displayed. Press the **SEL** button.



Use the **▲** and **▼** buttons to set the intensity from 1% to 99.9%, and press the **SEL** button.



Your PP520 is ready to use.

## 9.5 Setting up pulsed operation

Press the **SEL** button for 1 second and follow the steps below:



**CH1** is displayed. Use the **▲** and **▼** buttons to select **CH2** if you wish to set up channel 2. Press the **SEL** button.



Use the ▲ and ▼ buttons to select **SPu** and press the **SEL** button.



**bri** is displayed. Press the **SEL** button.



Use the ▲ and ▼ buttons to set the intensity from 1% to 999%, and press the **SEL** button.



**deL** is displayed. Press the **SEL** button to set up the delay time as described in [Section 9.6, Setting pulse delay and width times](#).

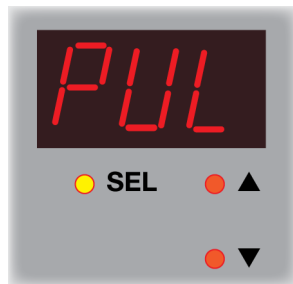

**PUL** is displayed. Press the **SEL** button to set up the pulse width time as described in [Section 9.6, Setting pulse delay and width times](#).



Your PP520 is ready to use.

## 9.6 Setting pulse delay and width times

When the PP520 displays numeric values you can change, the right hand digit flashes. You can then use the ▲ and ▼ buttons to set the required value.

To set the pulse delay and pulse width values, a scheme is used where the exponent (power of ten) of the value is set. The exponent values are as follows:

Exponent value	Multiplier	Number format	Range of values
E-3	0.001	999.	Values displayed in milliseconds from 1ms to 999ms in steps of 1ms
E-4	0.0001	99.9	Values displayed in milliseconds from 0.1ms to 99.9ms in steps of 0.1ms
E-5	0.00001	9.99	Values displayed in milliseconds: PP520: 0.02ms to 980ms in steps of 0.02ms PP520F: 0.01ms to 9.99ms in steps of 0.01ms
E-6	0.000001	999.	Values displayed in microseconds: PP520: 20µs to 980µs in steps of 20µs PP520F: 1µs to 999µs in steps of 1µs

To enter pulse delay and width times, follow the key strokes below:

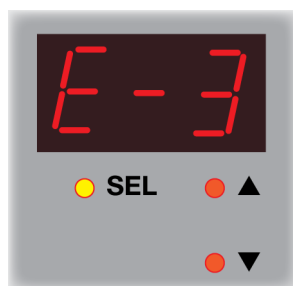

Use the ▲ and ▼ buttons to select **E-3** to enter values from 1ms to 999ms in steps of 1ms. Press the **SEL** button.



Use the ▲ and ▼ buttons to select the desired value. Press the **SEL** button.



Use the ▲ and ▼ buttons to select **E-4** to enter values from 0.1ms to 99.9ms in steps of 0.1ms. Press the **SEL** button.



Use the ▲ and ▼ buttons to select the desired value. Press the **SEL** button.



Use the ▲ and ▼ buttons to select **E-5** to enter values from 0.02ms to 9.98ms in steps of 0.02ms using a PP520 or 0.01ms to 9.99ms in steps of 0.01ms using a PP520F.

Press the **SEL** button.



Use the ▲ and ▼ buttons to select the desired value. Press the **SEL** button.

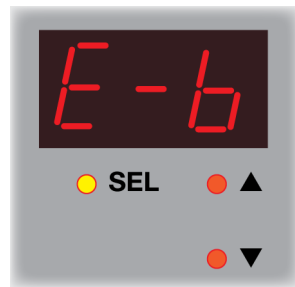

Use the ▲ and ▼ buttons to select **E-6** to enter values from 20 $\mu$ s to 980 $\mu$ s in steps of 20 $\mu$ s using a PP520, or 1 $\mu$ s to 999 $\mu$ s in steps of 1 $\mu$ s using a PP520F.

Press the **SEL** button.



Use the ▲ and ▼ buttons to select the desired value. Press the **SEL** button.

**Note:** When a light is pulsed, the PP520 shows that a trigger has occurred by displaying **PUL** in the display window.

## 10 Ethernet communication

You may need to ask your network administrator for advice about setting up the Ethernet connection.

Ethernet set up is not affected by cold booting the PP520.

See Application note APP923 (available from [www.gardasoft.com](http://www.gardasoft.com)) for troubleshooting Ethernet problems.

### 10.1 Connection

The Ethernet link uses a 10Base-T connection on an RJ45 connector. The PP520 is usually connected to a network switch, hub or router, but you can connect it directly into the network port on a PC using a crossover cable.

### 10.2 IP address

The PP520 needs an IP address to communicate over Ethernet. There are two ways to get an IP address; either programmed into the unit or using DHCP.

For DHCP mode, the PP520 acquires its IP address, subnet mask and gateway address from a DHCP server. Otherwise the PP520 has a fixed IP address, subnet mask and gateway address.

DHCP mode or the IP address can be set and read using the GardasoftMaint program available at [www.gardasoft.com](http://www.gardasoft.com).

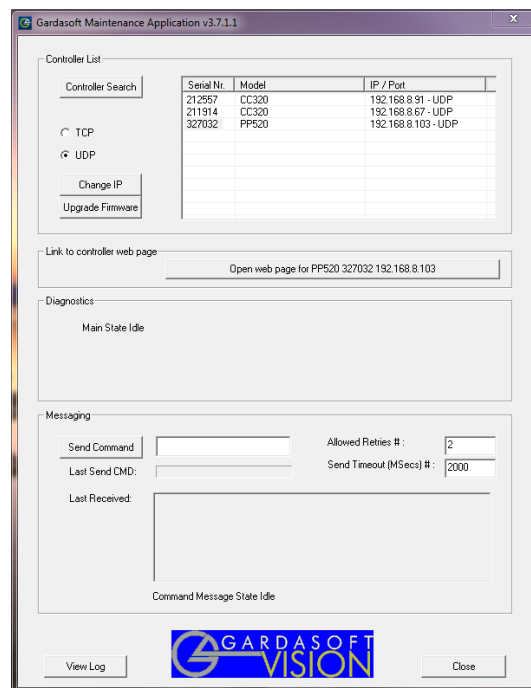

GardasoftMaint allows you to view the controllers on your network, change their IP addresses and upgrade their firmware if it becomes necessary. In

the messaging section of GardasoftMaint, you can communicate with your controller using the commands explained in [Section 12, Command configuration](#). You can also open the selected controller's web pages at the click of a button. For more information about the PP520's web pages, refer to [Section 11, Webpage configuration](#)

### 10.2.1 DHCP

Most networks use a DHCP server. If there is a PC on the network, you may be able to find out whether a PC on the same network uses DHCP as follows:

- i. Go to the Control Panel.
- ii. Select **Network Connections**.
- iii. Right click on **Local Area Connection**. Select **Properties**.
- iv. From the list, select **Internet Protocol (TCP/IP)**, press **Properties**.

If 'Obtain an IP address automatically' is set, then DHCP is probably used. However, there may be an alternative fixed IP address on the **Alternative Configuration** tab.

You can find out what IP address is being used by a PC at any time by following the steps below:

- i. Go to the Control Panel.
- ii. Select **Network Connections**.
- iii. Right click on **Local Area Connection**. Select **Status**.
- iv. Select the **Support** tab. The IP address is displayed.

### 10.2.2 Fixed IP address

When using a fixed IP address, you must ensure that you use an IP address that is not being used by any other device on the network. It is usual to keep the first three numbers of the IP address the same as other devices and to change only the last number. For example, if you have a network consisting of a PC (IP address 192.168.1.35) and two PP520s could be allocated addresses 192.168.1.201 and 192.168.1.202.

## 10.3 Front panel Ethernet set up

You can set up the Ethernet connection from the PP520's front panel. Press and hold the **SEL** button until **CH1** is displayed:

If you want to set up DHCP, use the ▲ and ▼ buttons to select **dhc**, and press the **SEL** button.

If you want to set up a fixed IP address, follow the steps below:





Use the ▲ and ▼ buttons to select **FIP** and press the **SEL** button.



**IP1** is displayed. Press the **SEL** button and use the ▲ and ▼ buttons to select the first three digits of the IP address. Press the **SEL** button again.



**IP2** is displayed. Press the **SEL** button and use the ▲ and ▼ buttons to select the second three digits of the IP address. Press the **SEL** button again.



**IP3** is displayed. Press the **SEL** button and use the ▲ and ▼ buttons to select the third three digits of the IP address. Press the **SEL** button again.



**IP4** is displayed. Press the **SEL** button and use the ▲ and ▼ buttons to select the fourth three digits of the IP address. Press the **SEL** button again.



**Sb1** is displayed. Press the **SEL** button and use the ▲ and ▼ buttons to select the first three digits of the subnet mask. Press the **SEL** button again.



**Sb2** is displayed. Press the **SEL** button and use the ▲ and ▼ buttons to select the second three digits of the subnet mask. Press the **SEL** button again.



**Sb3** is displayed. Press the **SEL** button and use the ▲ and ▼ buttons to select the third three digits of the subnet mask. Press the **SEL** button again.



**Sb4** is displayed. Press the **SEL** button and use the ▲ and ▼ buttons to select the fourth three digits of the subnet mask. Press the **SEL** button again.



**gt1** is displayed. Press the **SEL** button and use the ▲ and ▼ buttons to select the first three digits of the gateway address. Press the **SEL** button again.



**gt2** is displayed. Press the **SEL** button and use the ▲ and ▼ buttons to select the second three digits of the gateway address. Press the **SEL** button again.



**gt3** is displayed. Press the **SEL** button and use the ▲ and ▼ buttons to select the third three digits of the gateway address. Press the **SEL** button again.



**gt4** is displayed. Press the **SEL** button and use the ▲ and ▼ buttons to select the fourth three digits of the gateway address. Press the **SEL** button again.



Your PP520 is ready to use.

## 10.4 Reading an IP address

When an IP address has been assigned using DHCP, the address can be read from the front panel as follows. Press and hold the **SEL** button until **CH1** is displayed. Use the ▲ and ▼ buttons to select **Eth**, press the **SEL** button and follow the instructions below:



Use the ▲ and ▼ buttons to select **rIP** and press the **SEL** button.



**IP1** is displayed. Press the **SEL** button to read the first three digits of the IP address.

Press the **SEL** button again.



**IP2** is displayed. Press the **SEL** button to read the second three digits of the IP address.

Press the **SEL** button again.



**IP3** is displayed. Press the **SEL** button to read the third three digits of the IP address.

Press the **SEL** button again.



**IP4** is displayed. Press the **SEL** button to read the remaining digits of the IP address.

Press the **SEL** button again.



Your PP520 is ready for normal operation.

## 11 Webpage configuration

You can set up the PP520 through its own internal web pages. Click the **Open webpage...** button in GardasoftMaint to take you directly to the PP520's webpages. You can also type the controller's IP address (displayed in GardasoftMaint) into your web browser, which will display the Main screen. GardasoftMaint software is available from [www.gardasoft.com](http://www.gardasoft.com).

### 11.1 Main page

The main page (shown below) is the first to open when you access the PP520's webpages. This gives the controller's hardware and firmware revision levels and the serial number. It also tells you the power being dissipated and the PP520's internal temperature.

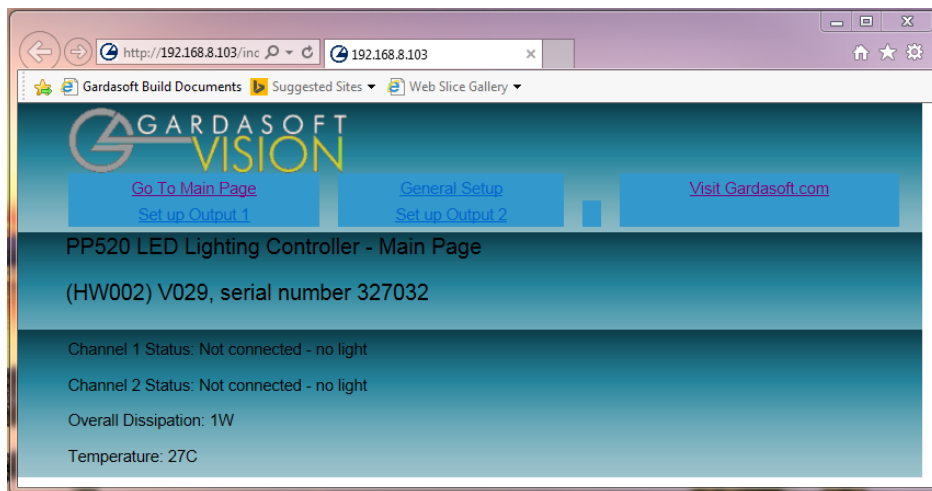

## 11.2 Configuration page

There is one configuration page for each output channel as shown below:

The screenshot shows a web browser window displaying the configuration page for a PP520 LED Lighting Controller - Channel 1. The page title is "PP520 LED Lighting Controller - Channel 1 Configuration (HW002) V029, serial number 327032".

**Configuration Parameters:**

- Mode: Continuous (dropdown)
- Trigger: Trigger 1 (dropdown)
- Brightness (%): 50.0 (input field)
- Pulse Delay: 1.000ms (input field)
- Pulse Width: 1.000ms (input field)
- Retrigger Delay: 0.0us (input field)
- Flags: Autosense  Error Detect  Pos Trigger

**Status Table:**

Status:	Not connected - no light
Dissipation:	0W
Measured Current:	0.005A
Lighting Voltage:	1.0V
Expected Voltage:	No value
Supply Voltage:	23.6V
Duty Cycle:	100%
Voltage Drop:	22.6V
Trigger Count:	0, Input State = 0

**Current Rating:** 0.000A (input field) with an Update button.

You can set up all the parameters for each output channel. Pressing the **Submit** button updates the PP520 configuration and saves the changes to non-volatile memory. On this page you can:

- Change the current rating and brightness of the light.
- View some measured voltages and the actual output current.
- Set the output mode: continuous, pulsed, or switched.
- Set the pulse parameters.

## 11.3 General setup page

The general setup page (shown below) allows you to set up or clear the webpage's password and set up the internal trigger. You can also enter any Ethernet command from Section 12, Command configuration.

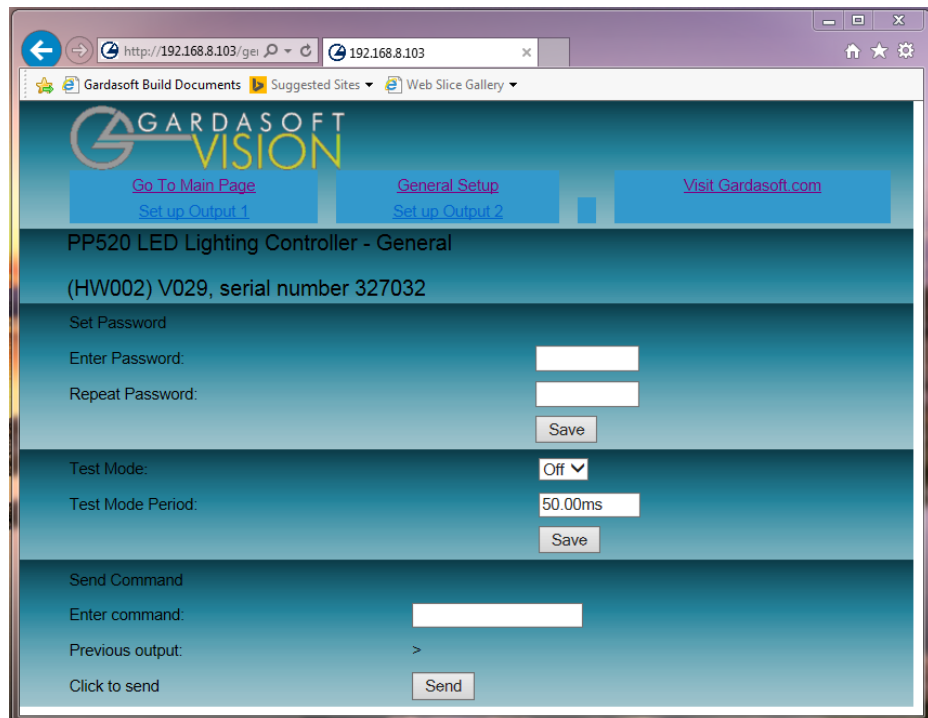

The screenshot shows a web browser window displaying the 'General Setup' page for a PP520 LED Lighting Controller. The browser's address bar shows the URL 'http://192.168.8.103/gei'. The page features the GARDASOFT VISION logo at the top, with navigation links for 'Go To Main Page', 'General Setup', and 'Visit Gardasoft.com'. Below the logo, there are links for 'Set up Output 1' and 'Set up Output 2'. The main content area is titled 'PP520 LED Lighting Controller - General' and includes the device identifier '(HW002) V029, serial number 327032'. The 'Set Password' section contains two input fields for 'Enter Password:' and 'Repeat Password:', followed by a 'Save' button. The 'Test Mode' section has a dropdown menu set to 'Off' and a text input field for 'Test Mode Period' containing '50.00ms', with a 'Save' button below. The 'Send Command' section includes an 'Enter command:' input field, a 'Previous output:' field showing '>', and a 'Send' button.

## 12 Command configuration

The PP520 can be configured through the Ethernet connection using UDP or TCP/IP. You can enter commands through the unit's web pages or by using GardasoftMaint (available to download from [www.gardasoft.com](http://www.gardasoft.com)).

### 12.1 Command structure

Communication consists of commands sent by the host (controlling PC). All output generated by the command is returned in reply UDP or TCP/IP packets. The last character sent is > ('greater than' symbol). Once this is received, the host knows that the command has been completed.

We recommend that the host waits for the > symbol before sending the next command. UDP communications are not guaranteed to arrive, so the host software must be able to cope with lost messages.

Using the **GT** command, a host can request that a message is sent to it whenever an error occurs.

Several commands can be put into one command line by separating them by a semi-colon (;). The PP520 sends any replies to the commands followed by a > character to show that the command line has completed.

All commands comprise a code of two letters followed by any optional parameters. All spaces in the commands are ignored.

Numeric parameters are separated by a comma (,). For a parameter which is a time period, the default units are milliseconds. 's', 'ms' or 'us' can be added to the end of the number to indicate seconds, milliseconds or microseconds. For currents, 'A' or 'mA' can be added to indicate amps or milliamps. The default unit is amps.

**Note:** parameters are in 'USA/UK' format so that a half is written '0.5' not '0,5'. For example:

Parameter	Meaning
0.1	0.1 milliseconds
200µs	200 microseconds
0.1s	0.1 seconds
100mA	100mA
2.45A	2.45A
2.3	2300mA or 2.3A

The command codes and their meaning are described in the remainder of this section. The upper case commands are shown, followed by lower case letters denoting the numeric argument.



## Save the settings to memory

### AW

Once the settings are saved to memory, they are retained when the unit is switched off. If this is not done, the changes to the settings are volatile, and if the unit is switched off they revert to the settings in force when the last **AW** command was issued.

## Report the configuration

### ST

The typical output is:

```
CH 1, MD 2, IP 4, CS 0.100A, SE 75.0, DL 2.0us, PU 300.0us, RT 500.0us, FL 1  
CH 2, MD 0, IP 2, CS 0.100A, SE 25.8, DL 1.000ms, PU 1.000ms, RT 0.0us, FL 0
```

Where:

CH	Channel number
MD	Mode: 0 = continuous, 1 = pulse, 2 = switched
IP	Trigger input: 1, 2
CS	Current rating of the light
SE	Brightness percentage setting
DL	Pulse delay
PU	Pulse width
RT	Retrigger delay

### ST0

Reports the general settings, The typical output is:

```
TM 1, TP 20.00m
```

This command reports the settings for a single channel.

### STc

Where:

**c** = Channel number (1 or 2)

## Enable Ethernet messages

### GTm

Where:

- m** = 0 to disable Ethernet messages
- = 1 to enable Ethernet messages.

When Ethernet messages are enabled, any error reports are sent to the most recent UDP or TCP address from which a command has been received.

Messages are of the form:

Evtc,e

Where:

- c** the channel number, or 0 for no channel
- e** event value:
  - 32 to 47 are lighting error codes
  - 128 = light detected and waiting for current rating
  - 129 = light detected and not waiting for current rating.

## Clear any errors

### GR

If Ethernet messages are not enabled, the last event or error number can be read by this command. Any error displayed on the unit is cleared, so if there was a lighting error, the PP520 resumes auto-sensing on that channel.

The reply is in the same form as the **GT** command above. If there are no outstanding events or errors, only the prompt '>' is returned.

## Clear settings

### CL

Clears the output channel configuration. This excludes the Ethernet settings. If the auto sense flag is set on any channel, then the flag and the current rating are preserved.

## Set/clear the webpage password

### EY

#### EY asc1, asc2, asc3, asc4, asc5, asc6

This command sets the password required to access the webpages. If **EY** is entered on its own then the password is cleared. There are six optional parameters, which are ASCII values for a password from one to six letters. A value of 65 is 'A', 66 is 'B', etc to 90 is 'Z'.

## Report the version of firmware running in the PP520

### VR

This command returns the firmware version. For example:

```
PP420 (HW001) V029
```

## Disable keyboard

### KBd,c

Where:

- d** = 0 to enable the keyboard  
= 1 to disable the keyboard
- c** unlock code

In some applications it may be necessary to disable the keyboard so that operation can only be controlled from the Ethernet port. This command is cleared on a power cycle.

## 12.2 Lighting commands

### Set the SafeSense mode

#### REc,m

Where:

- c** output channel (1 or 2)
- m** SafeSense mode:
  - Bit 0 = **0**: S flag set (prompt for current rating enabled)  
**1**: S flag cleared (prompt for current rating disabled)
  - Bit 1 = **0**: E flag set (error detection enabled)  
**1**: E flag cleared (error detection disabled)
  - Bit 2 = **0**: P flag set (positive triggers)  
**1**: P flag cleared (negative triggers)

### Set the output current rating

This command changes the current rating for a light:

#### RRv,c

Where:

- c** output channel (1 or 2)
- v** rated current (10mA to 2A)

### Set continuous mode

The output is set to continuous mode at a percentage of full brightness:

**RSc,s**

Where:

- c** output channel (1 or 2)
- s** setting in percent (0 to 100)

### Set switched mode

The output is set to continuous mode at a percentage of full brightness:

**RWc,s**

Where:

- c** output channel (1 or 2)
- s** setting in percent (0 to 100)

### Set pulse mode

The output can be set up to pulse on a trigger input. You can configure the delay from the trigger to the start of the pulse, the length of the pulse and the brightness.

An error is generated if the brightness setting requires a current greater than 10A or if the combination of pulse width and setting is not allowed.

**RTc,p,d,s**

Where:

- c** output channel (1 or 2)
- p** pulse width in milliseconds (0.02 to 999)
- d** delay from trigger to pulse in milliseconds (0.02 to 999)
- s** brightness setting in percent (0 to 999)

### Set the trigger input

This command sets which input is used for pulse and switched output modes.

**RPc,p**

Where:

- c** output channel (1 or 2)
- p** trigger input (1 or 2)

### Simulate an input trigger

This command simulates a trigger pulse. If the channel is in pulse mode, it will pulse and show **PUL** in the display.

#### TRc

Where **c** = the input channel to be pulsed (1 or 2)

### Set an internal trigger

This command enables or disables the internal trigger. When enabled, all outputs are triggered simultaneously using an internal trigger signal. This setting can be saved to non-volatile memory using the **AW** command.

**TT0** Disable the internal trigger

**TT1** Enable the internal trigger and use the previously set period

**TT1,p** Enable the internal trigger and set the period.

Where:

**p** = period of the trigger in milliseconds

For example:

TT1,200 Set the internal trigger to 200ms (5Hz)

TT1,500US Set the internal trigger to 500µs (2kHz)

## 12.3 Command summary

Command	Example	Effect
AW	AW	Save changes.
ST	ST	Show configuration.
GT	GT1	Enable Ethernet messages.
GR	GR	Get any error codes.
CL	CL	Clear all settings except Ethernet.
EY	EY,65,66	Set webpage password to 'PW'.
VR	VR	Read the firmware version.
RE	RE1,3	Set channel 1 to ignore lighting errors and not prompt for the current rating of a light when it is connected.
RR	RR1,0.2	Set the rating of channel 1 to 0.2A.

<b>Command</b>	<b>Example</b>	<b>Effect</b>
RS	RS2,65	Set channel 2 to 65% brightness continuous.
RW	RW1,50	Set channel 1 to 50%, switched by trigger 1.
RT	RT2,3,4,50	Set channel 2 to 3ms pulses, delayed by 4ms, at 50% brightness.
RP	RP1,2	Use trigger input 3 for channel 2.
TR	TR2	Simulate a trigger on trigger input 2.
TT	TT1,1ms	Set internal triggers every 1ms.

## 13 Reference information

### 13.1 Timings

**Switched mode:** The maximum delay from a trigger input changing to the output current being turned on or off is 10 $\mu$ s.

**Pulse Mode:** For the PP520F the minimum pulse delay is about 4 $\mu$ s.

### 13.2 Specifications

Parameter	Value	Notes
Digital supply voltage (PSU+)	12 - 48VDC regulated	Must be at least 1V greater than the load potential difference at maximum current.
Quiescent current	150mA	This is when using a 12V supply; the current is lower at 24V.
Input enable level	From 4.5V to 24V	This is the voltage applied between + and - of each input.
Input disable level	< 1V	See above.
Typical trigger input current	3mA at 4.5V 22mA at 24V	
Max output current per channel	2A continuous, 10A pulsed	
Ambient temperature during operation	5°C to 40°C	The ambient temperature may need to be lower if the PP520 is dissipating a lot of heat.
Total allowed power dissipation without heat sinking ( $P_D$ )	8W maximum	See Section 7, PP520 heat output.
Pulse timing	20 $\mu$ s to 1s	PP520
	1 $\mu$ s to 1s	PP520F
Delay timing	20 $\mu$ s to 1s	PP520
	4 $\mu$ s to 1s	PP520F

### 13.3 Error codes

Error number	Reason
Err 1	A parameter value is invalid.
Err 2	Command is not recognised.
Err 3	Numeric value in wrong format.
Err 4	Wrong number of parameters.
Err 5	One of the parameters is out of range. The value of the parameter has been adjusted. For example, sending an <b>RT</b> command with a delay of 0 will get a reply of 'Err 5'. When the settings are viewed the delay will have been set to 20µs (PP520) or 4µs (PP520F).
Err 8, 12	EEPROM corrupt. The configuration has been cleared.
Err 20	Couldn't save settings to EEPROM.
Err 27	Cannot read Ethernet settings from EEPROM; they may be incorrect.
<b>PO</b> , Err 34	Internal power dissipation is too high. Output turned off.
<b>OP</b> , Err 35	Output current to lighting is too low.
<b>OP</b> , Err 39	There is not enough supply voltage for the requested output current.
<b>SH</b> , Err 36	The output is short circuit.
Err 42	The output current is too high.
<b>HI</b> , Err 37	The voltage required for the lighting has increased too much. Check for ageing of the lighting or a failed LED.
<b>LO</b> , Err 38	The voltage required for the lighting has decreased too much. Check for ageing of the lighting or a failed LED.
Err 44	Temperature error. The PP520 is too hot and has switched off to protect itself.
Err 40, 41, 45	More current is being output than should be, so the PP520 has turned off the outputs. This may be caused by a hardware error. Check with your distributor.



Error number	Reason
<b>FAt</b>	<b>Fatal:</b> The PP520 is too hot. The PP520 is fitted with a thermal cut-out. If the internal temperature reaches 62°C (corresponding to a case temperature of 70°C), the outputs are turned off. This message is displayed until the PP520 has cooled down to below 62°C.
<b>FAC</b>	<b>Fatal:</b> One channel is producing more output current than expected.

Issue 018 - April 2017

© Copyright 2017 Gardasoft Vision Ltd

Gardasoft LLC  
Oak Ridge Road  
Weare  
New Hampshire  
03281 USA  
tel: +1 603-657-9026

Gardasoft Vision Ltd  
Trinity Court  
Buckingway Business Park  
Cambridge CB24 4UQ UK  
tel: +44 1954 234970  
fax: +44 1954 231567